

**HONDA**

**CB1000**

**OWNER'S MANUAL**

**MANUEL DU CONDUCTEUR**

**FAHRER-HANDBUCH**

## **IMPORTANT NOTICE**

- **OPERATOR AND PASSENGER**

This motorcycle is designed to carry the operator and one passenger. Never exceed the maximum weight capacity as shown on the tyre information label.

- **ON-ROAD USE**

This motorcycle is designed to be used only on the road.

- **READ THIS OWNER'S MANUAL CAREFULLY**

Pay special attention to statements preceded by the following words:

### **⚠ WARNING**

**Indicates a strong possibility of severe personal injury or death if instructions are not followed.**

### **CAUTION:**

**Indicates a possibility of personal injury or equipment damage if instructions are not followed.**

**NOTE:** Gives helpful information.

This manual should be considered a permanent part of the motorcycle and should remain with the motorcycle when resold.

# **HONDA CB1000 OWNER'S MANUAL**

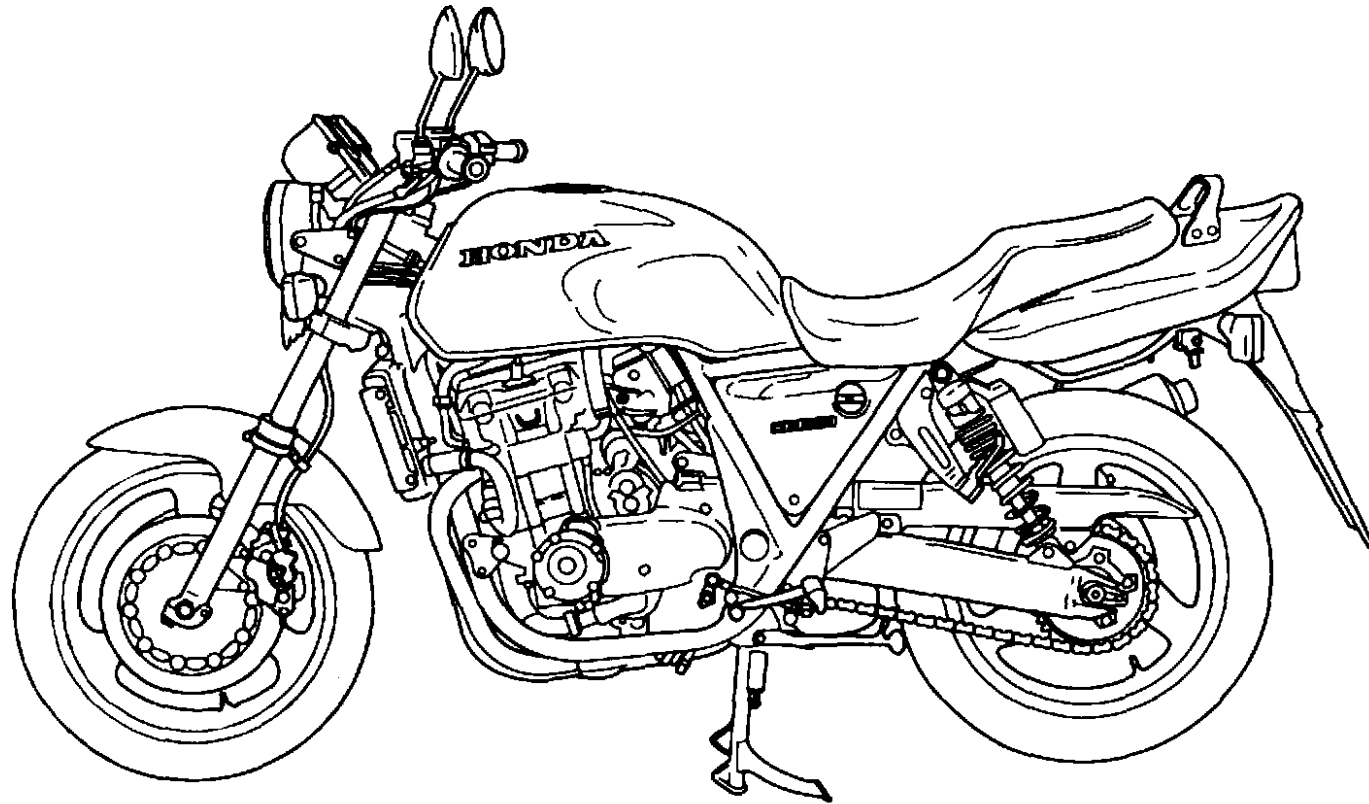

**All information in this publication is based on the latest production information available at the time of approval for printing. HONDA MOTOR CO.,LTD. reserves the right to make changes at any time without notice and without incurring any obligation.**

**No part of this publication may be reproduced without written permission.**

# WELCOME

The motorcycle presents you a challenge to master the machine, a challenge to adventure. You ride through the wind, linked to the road by a vehicle that responds to your commands as no other does. Unlike an automobile, there is no metal cage around you. Like an airplane, a pre-ride inspection and regular maintenance are essential to your safety. Your reward is freedom.

To meet the challenges safely, and to enjoy the adventure fully, you should become thoroughly familiar with this owner's manual **BEFORE YOU RIDE THE MOTORCYCLE**.

When service is required, remember that your Honda dealer knows your motorcycle best. If you have the required mechanical "know-how" and tools, your dealer can supply you with an official Honda Service Manual to help you perform many maintenance and repair tasks.

Pleasant riding, and thank you for choosing a Honda !

- Following codes in this manual indicate each country.

E	UK	ED	Europe	SW	Switzerland
F	France	SP	Spain	AR	Austria
G	Germany	ND	Northern Europe	IIG	Germany (Type II)
U	Australia				

- The specifications may vary with each locale.

# OPERATION

page

1	MOTORCYCLE SAFETY
1	Safe Riding Rules
2	Protective Apparel
3	Modifications
4	Loading and Accessories
7	PARTS LOCATION
10	Instruments and Indicators
14	MAJOR COMPONENTS (Information you need to operate this motorcycle)
14	Suspension
15	Brakes
19	Clutch
20	Coolant
22	Fuel
26	Engine Oil
27	Tubeless Tyres
30	ESSENTIAL INDIVIDUAL COMPONENTS
30	Ignition Switch

page

31	Right Handlebar Controls
33	Left Handlebar Controls
34	FEATURES (Not required for operation)
34	Steering Lock
35	Helmet Holder
36	Seat
36	Document Compartment
37	Side Cover
37	Storage Compartment
38	Rear Cowl
39	OPERATION
39	Pre-ride Inspection
40	Starting the Engine
44	Running-in
45	Riding
46	Braking
47	Parking
48	Anti-theft Tips

# MAINTENANCE

page	
49	MAINTENANCE
50	Maintenance Schedule
53	Tool Kit
54	Serial Numbers
55	Colour Label
55	Maintenance Precautions
56	Engine Oil
59	Crankcase Breather
60	Spark Plugs
63	Throttle Operation
64	Idle Speed
65	Air cleaner
66	Drive Chain
71	Drive Chain Slider
72	Side Stand
73	Wheel Removal
79	Brake Pad Wear
81	Battery
83	Fuse Replacement
85	Bulb Replacement
89	Stoplight Switch Adjustment

page	
90	CLEANING
92	STORAGE GUIDE
92	Storage
94	Removal from Storage
95	SPECIFICATIONS
99	NOISE CONTROL SYSTEM (AUSTRALIA ONLY)

# MOTORCYCLE SAFETY

## **⚠ WARNING**

**\* Motorcycle riding requires special efforts on your part to ensure your safety. Know these requirements before you ride:**

### **SAFE RIDING RULES**

1. Always make a pre-ride inspection (page 39) before you start the engine. You may prevent an accident or equipment damage.
2. Many accidents involve inexperienced riders. Most countries require a special motorcycle riding test or license. Make sure you are qualified before you ride. NEVER lend your motorcycle to an inexperienced rider.
3. Many automobile/motorcycle accidents happen because the automobile driver does not “see” the motorcyclist. Make yourself conspicuous to help avoid the accident that wasn’t your fault:
  - Wear bright or reflective clothing.
  - Don’t ride in another motorist’s “blind spot.”
4. Obey all national and local laws and regulations.
  - Excessive speed is a factor in many accidents. Obey the speed limits, and NEVER travel faster than conditions warrant.
  - Signal before you make a turn or lane change. Your size and maneuverability can surprise other motorists.

5. Don't let other motorists surprise you. Use extra caution at intersections, parking lot entrances and exits, and driveways.
6. Keep both hands on the handlebars and both feet on the footpegs while riding. A passenger should hold on to the motorcycle or the operator with both hands and keep both feet on the passenger footpegs.

## **PROTECTIVE APPAREL**

1. Most motorcycle accident fatalities are due to head injuries: **ALWAYS** wear a helmet. You should also wear a face shield or goggles as well as boots, gloves and protective clothing. A passenger needs the same protection.
2. The exhaust system becomes hot during operation, and it remains hot for a while after stopping the engine. Be careful not to touch the exhaust system while it is hot. Wear clothing that fully covers your legs.
3. Do not wear loose clothing which could catch on the control levers, footpegs, drive chain or wheels.



## **MODIFICATIONS**

### **⚠ WARNING**

- \* Modification of the motorcycle, or removal of original equipment, may render the vehicle unsafe or illegal. Obey all national and local equipment regulations.**

## LOADING AND ACCESSORIES

### **⚠ WARNING**

**\* To prevent an accident, use extreme care when adding and riding with accessories and cargo. Addition of accessories and cargo can reduce a motorcycle's stability, performance and safe operating speed. Never ride an accessory-equipped motorcycle at speeds above 130 km/h (80 mph). And remember that this 130 km/h (80mph) limit may be reduced by installation of non-Honda accessories, improper loading, worn tyres and overall motorcycle condition, poor road or weather conditions. These general guidelines may help you decide whether or how to equip your motorcycle and how to load it safely.**

### **Loading**

The combined weight of the rider, passenger, cargo and additional accessories must not exceed the maximum weight capacity:

188 kg (415 lbs)

Cargo weight alone should not exceed:

27 kg (60 lbs)

1. Keep cargo and accessory weight low and close to the center of the motorcycle. Load weight equally on both sides to minimize imbalance. As weight is located further from the motorcycle's center of gravity, handling is proportionally affected.
2. Adjust tyre pressure (page 27) and rear suspension (page 14) to suit load weight and riding conditions.

3. Vehicle handling and stability can be adversely affected by loose cargo. Recheck cargo security and accessory mounts frequently.
4. Do not attach large or heavy items (such as a sleeping bag or tent) to the handlebars, fork, or fender. Unstable handling or slow steering response may result.

### **Accessories**

Genuine Honda accessories have been specifically designed for and tested on this motorcycle. Because the factory cannot test all other accessories, you are personally responsible for proper selection, installation, and use of non-Honda accessories. Always follow the guidelines under Loading, and these:

1. Carefully inspect the accessory to make sure it does not obscure any lights, reduce ground clearance and banking angle, or limit suspension travel, steering travel or control operation.
2. Large fork-mounted fairings or windshields, or poorly designed or improperly mounted fairings can produce aerodynamic forces that cause unstable handling. Do not install fairings that decrease cooling air flow to the engine.

3. Accessories which alter your riding position by moving hands or feet away from controls may increase reaction time in an emergency.
4. Do not add electrical equipment that will exceed the motorcycle's electrical system capacity. A blown fuse could cause a dangerous loss of lights or engine power.
5. This motorcycle was not designed to pull a sidecar or trailer. Handling may be seriously impaired if so equipped.
6. Any modification of the cooling system may cause overheating and serious engine damage. Do not modify the radiator shrouds or install accessories which block or deflect air away from the radiator.

# PARTS LOCATION

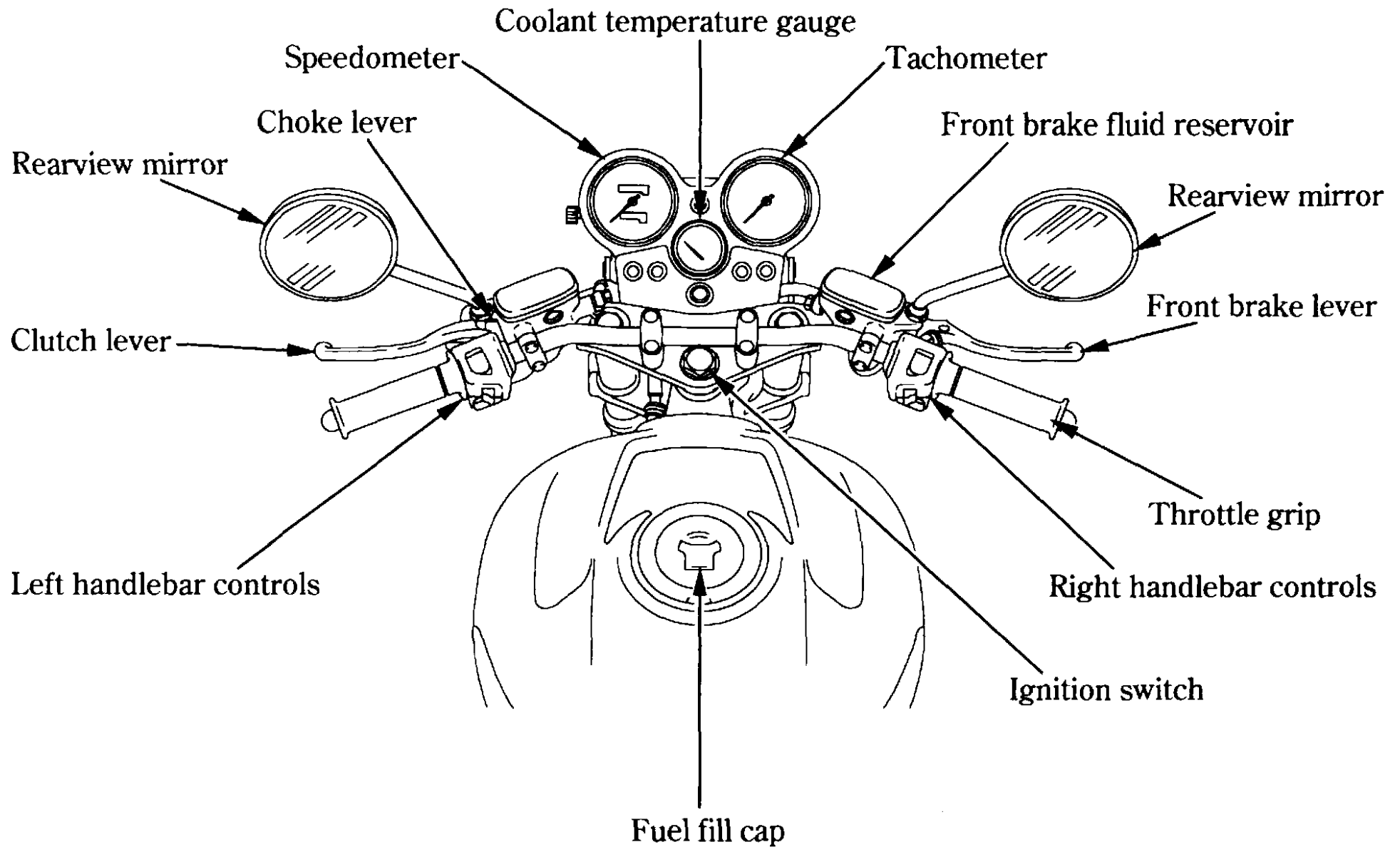

Document compartment

Battery

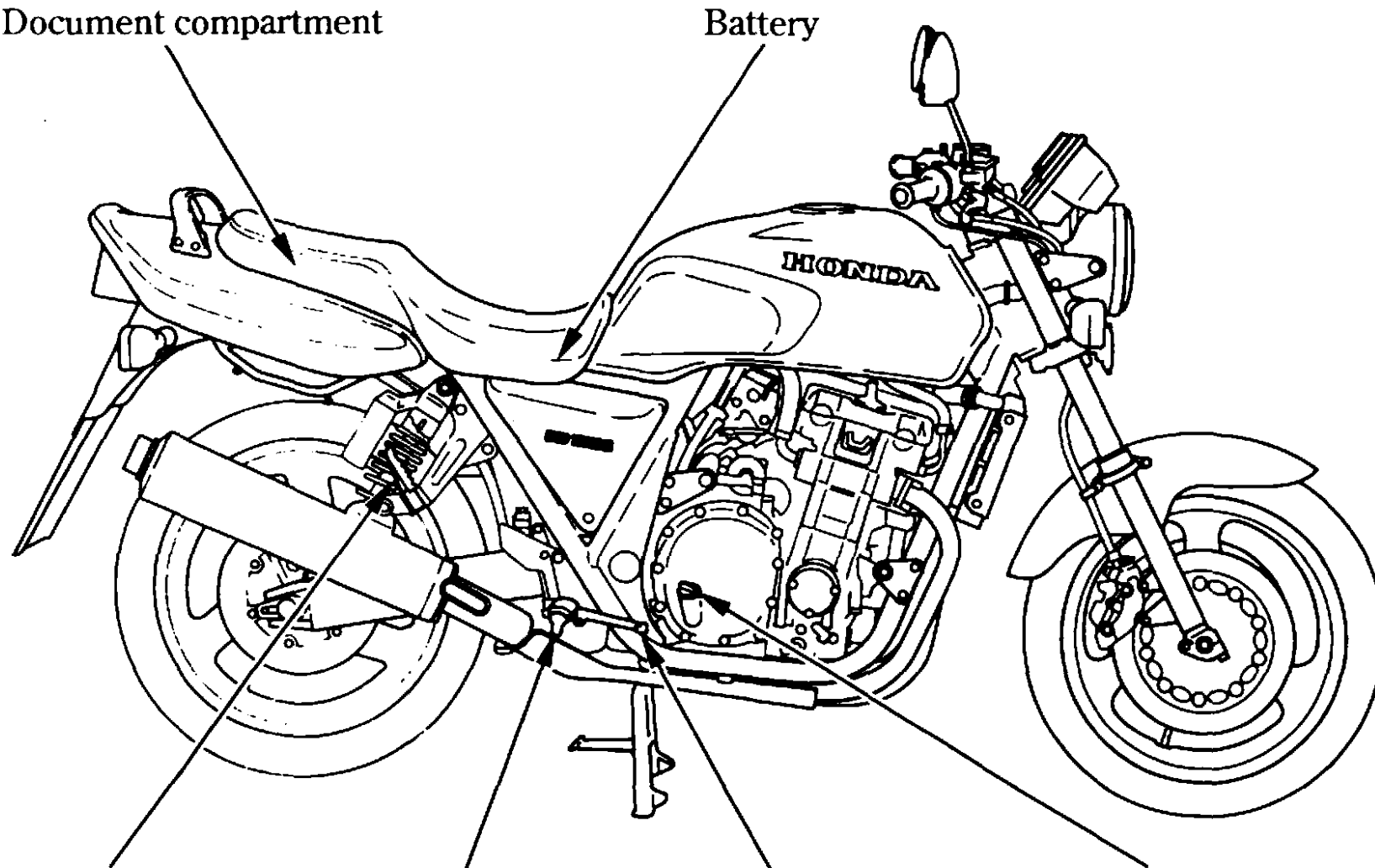

Passenger footpeg

Footpeg

Rear brake pedal

Oil filler cap/dipstick

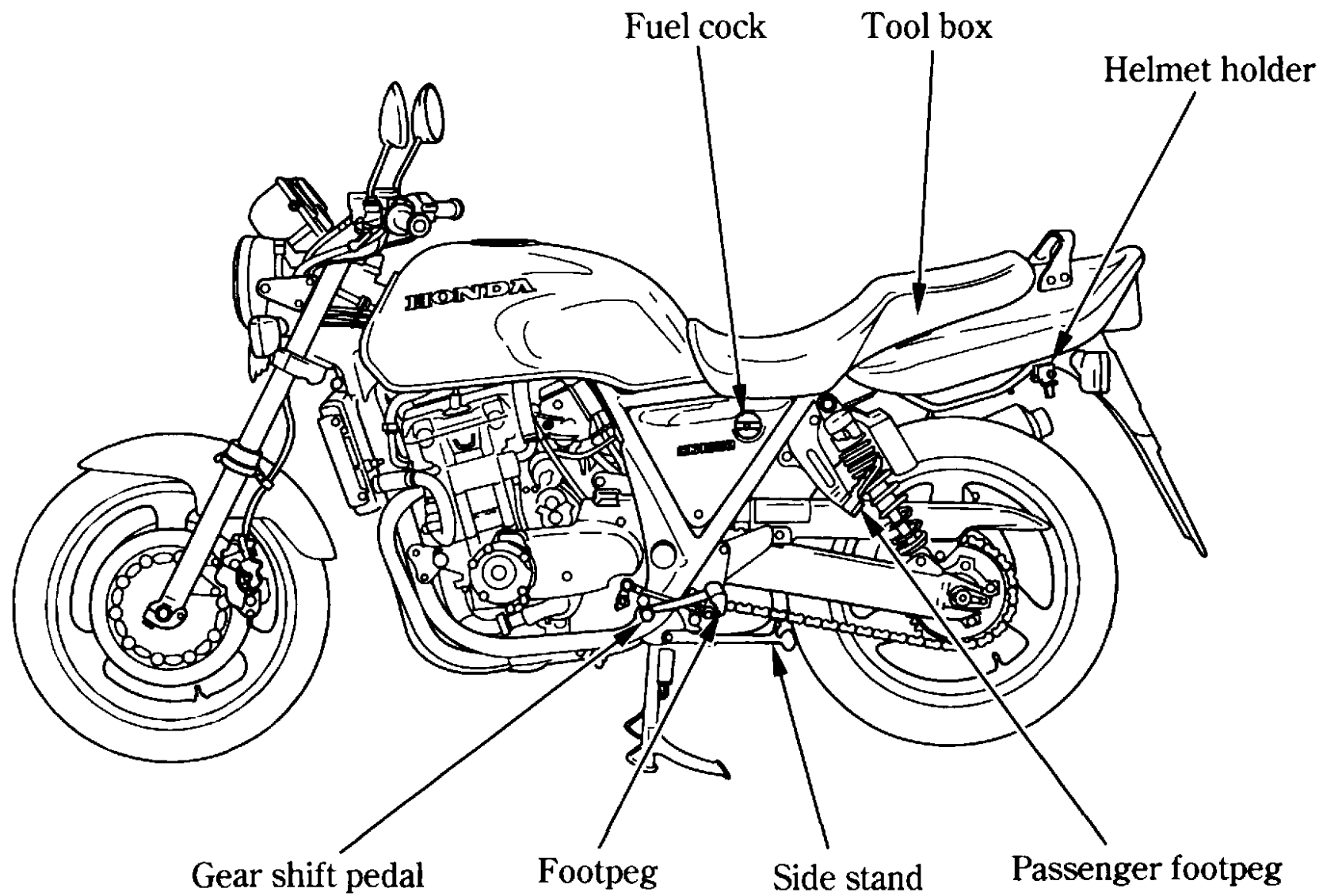

## INSTRUMENTS AND INDICATORS

The indicators are contained in the instrument panel. Their functions are described in the tables on the following pages.

- (1) Tripmeter
- (2) Speedometer
- (3) Odometer
- (4) Turn signal indicator
- (5) Tachometer
- (6) Tachometer red zone
- (7) High beam indicator
- (8) Side stand indicator
- (9) Coolant temperature gauge
- (10) Neutral indicator
- (11) Low oil pressure indicator
- (12) Tripmeter reset knob

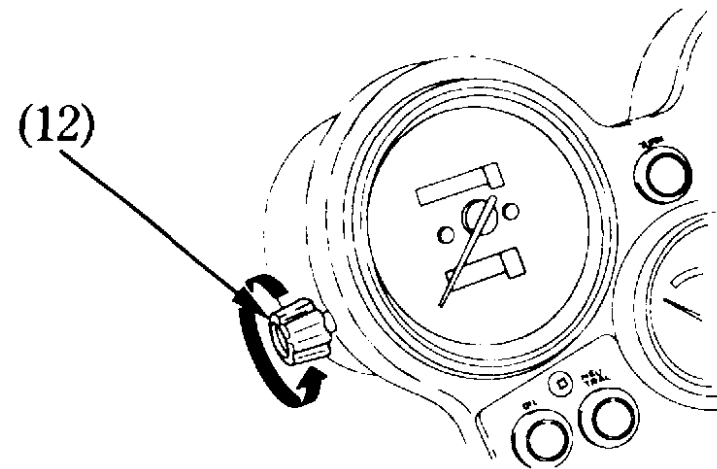
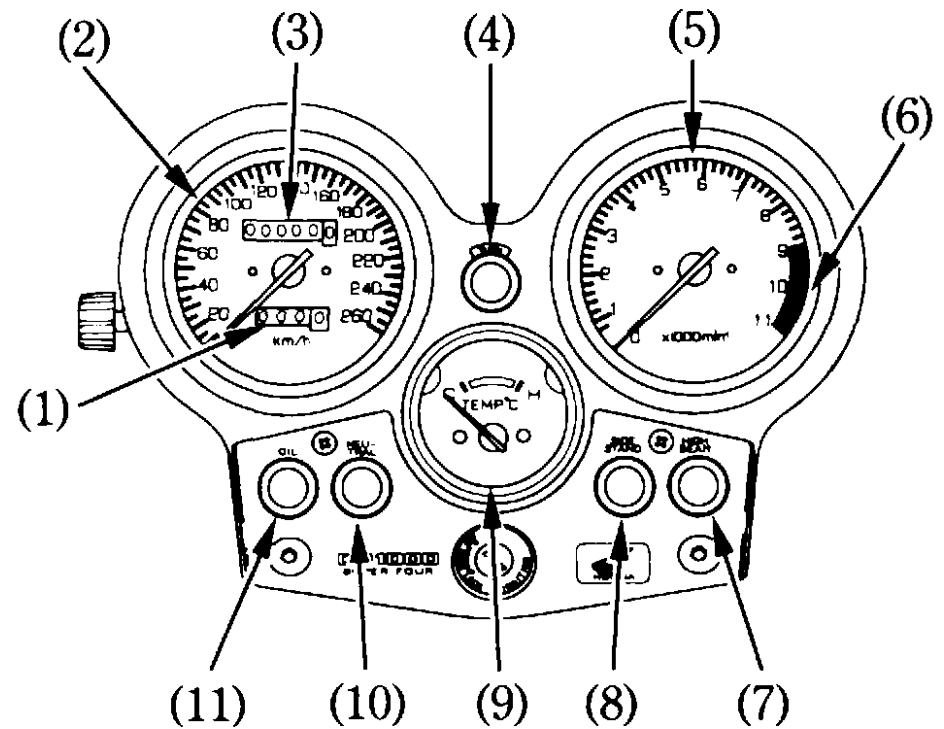



<b>(Ref.No.) Description</b>	<b>Function</b>
(1) Tripmeter	Shows mileage per trip.
(2) Speedometer	Shows riding speed.
(3) Odometer	Shows accumulated mileage.
(4) Turn signal indicator	Flashes when either turn signal is operated.
(5) Tachometer	Shows engine rpm.
(6) Tachometer red zone	<p>Never allow the tachometer needle to enter the red zone, even after the engine has been broken in.</p> <p><b>CAUTION:</b></p> <p><b>* Running the engine beyond recommended maximum engine speed (tachometer red zone) can damage the engine.</b></p>
(7) High beam indicator	Lights when the head light is on high beam.

<b>(Ref.No.) Description</b>	<b>Function</b>
(8) Side stand indicator	Lights when the side stand is put down. Before parking, check that the side stand is fully down; the light only indicates the side stand ignition cut-off system (page 40) is activated.
(9) Coolant temperature gauge	Shows coolant temperature (see page 13).
(10) Neutral indicator (green)	Lights when the transmission is in neutral.
(11) Low oil pressure indicator	<p>Lights when the engine oil pressure is below the normal operating range. Should light when ignition switch is ON and engine is not running. Should go out when the engine starts, except for occasional flickering at or near idling speed when engine is warm.</p> <p><b>CAUTION:</b>  * Running the engine with insufficient oil pressure may cause serious engine damage.</p>
(12) Tripmeter reset knob	Resets tripmeter to zero (0). Turn knob in direction shown.

## Coolant Temperature Gauge

When the needle begins to move above the C (Cold) mark, the engine is warm enough for the motorcycle to be ridden. The normal operating temperature range is within the section between the H and C marks. If the needle reaches the H (Hot) mark, stop the engine and check the reserve tank coolant level. Read pages 20 – 21 and do not ride the motorcycle until the problem has been corrected.

## CAUTION:

\* Exceeding maximum running temperature may cause serious engine damage.

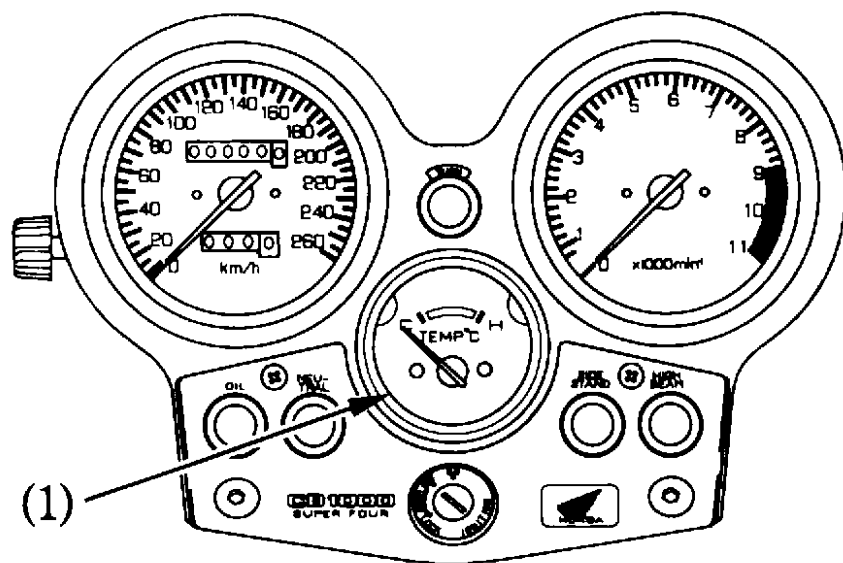

(1) Coolant temperature gauge

# MAJOR COMPONENTS (Information you need to operate this motorcycle)

## **▲WARNING**

**\* If the Pre-ride Inspection (page 39) is not performed, severe personal injury or vehicle damage may result.**

## **SUSPENSION**

Each shock absorber (1) has 5 adjustment positions for different load or riding conditions.

Use a pin spanner (2) to adjust the rear shocks.

Position 1 is for light loads and smooth road conditions. Positions 2 to 5 increase spring preload for a stiffer rear suspension, and can be used when the motorcycle is heavily loaded. Be certain to adjust both shock absorbers to the same position.

Standard position: 2

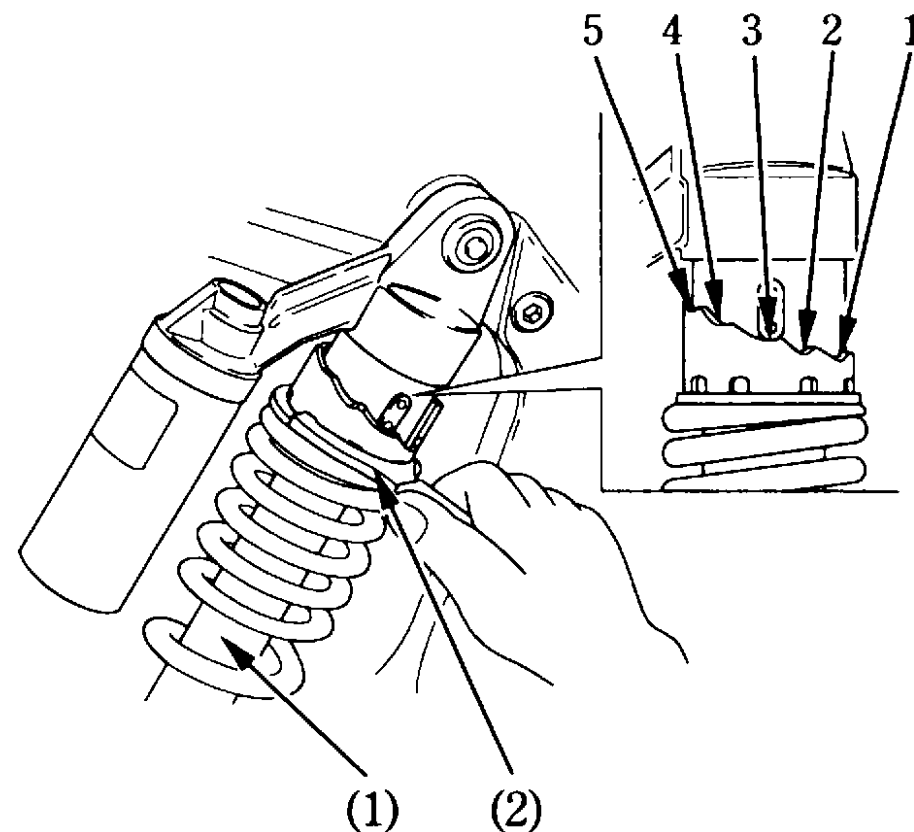

- (1) Shock absorber
- (2) Pin spanner

## **BRAKES**

Both the front and rear brakes are the hydraulic disc types.

As the brake pads wear, the brake fluid level drops.

There are no adjustments to perform, but fluid level and pad wear must be inspected periodically. The system must be inspected frequently to ensure there are no fluid leaks. If the control lever or pedal free travel becomes excessive and the brake pads are not worn beyond the recommended limit (page 79), there is probably air in the brake system and it must be bled. See your authorized Honda dealer for this service.

## **Front Brake**

### Front Brake Fluid Level:

#### **▲WARNING**

- \* **Brake fluid may cause irritation. Avoid contact with skin or eyes. In case of contact, flush thoroughly with water and call a doctor if your eyes were exposed.**
- \* **KEEP OUT OF REACH OF CHILDREN.**

#### **CAUTION:**

- \* **Handle brake fluid with care because it can damage plastic and painted surfaces.**
- \* **When adding brake fluid, be sure the reservoir is horizontal before the cap is removed or brake fluid may spill out.**
- \* **Use only DOT 4 brake fluid from a sealed container.**
- \* **Never allow contaminants such as dirt or water to enter the brake fluid reservoir.**

Brake fluid must be added to the reservoir whenever the fluid level begins to reach the LOWER level mark (1). Remove the screws (2), reservoir cover (3), diaphragm plate (4), and diaphragm (5). Fill the reservoir with DOT 4 BRAKE FLUID from a sealed container up to the upper level mark (6). Reinstall the diaphragm, diaphragm plate, and cover. Tighten the screws securely.

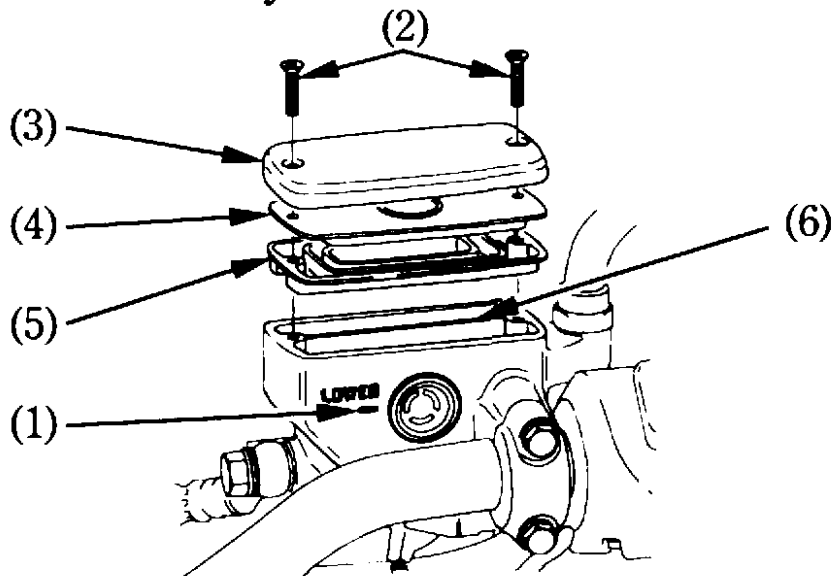

(FRONT)

- |                      |                      |
|----------------------|----------------------|
| (1) LOWER level mark | (4) Diaphragm plate  |
| (2) Screws           | (5) Diaphragm        |
| (3) Reservoir cover  | (6) UPPER level mark |

Front Brake Lever:

The distance between the tip of the brake lever (1) and the grip can be adjusted by turning the adjuster (2).

**CAUTION:**

- \* **Align the arrow (3) on the brake lever with index mark (4) on the adjuster.**

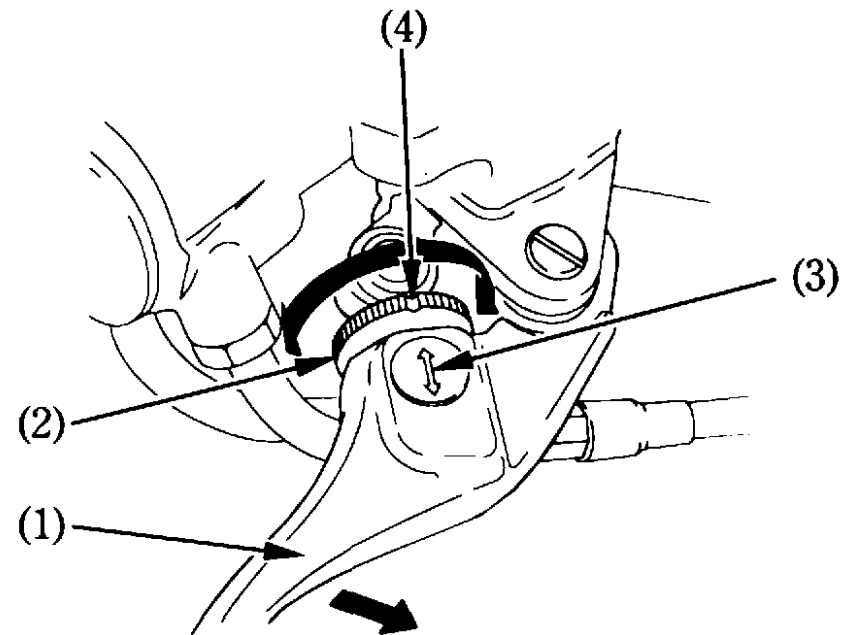

- |                 |                |
|-----------------|----------------|
| (1) Brake lever | (3) Arrow      |
| (2) Adjuster    | (4) Index mark |

## Rear Brake

### Rear Brake Fluid Level:

#### **▲WARNING**

- \* Brake fluid may cause irritation. Avoid contact with skin or eyes. In case of contact, flush thoroughly with water and call a doctor if your eyes were exposed.
- \* **KEEP OUT OF REACH OF CHILDREN.**

#### **CAUTION:**

- \* Handle brake fluid with care because it can damage plastic and painted surfaces.
- \* When adding brake fluid, be sure the reservoir is horizontal before the cap is removed or brake fluid may spill out.
- \* Use only DOT 4 brake fluid from a sealed container.
- \* Never allow contaminants such as dirt or water to enter the brake fluid reservoir.

Remove the seat (page 36).

Check that the fluid level is above the LOWER level mark (1) with the motorcycle in an upright position.

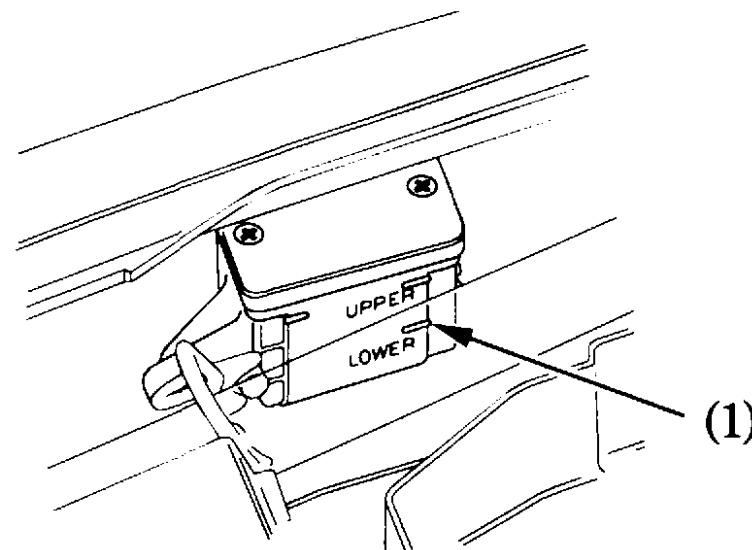

(1) LOWER level mark

Brake fluid must be added to the reservoir whenever the fluid level begins to reach the LOWER level mark (1). Remove the seat (page 36) and rear cowl (page 38). Remove the screws (2), reservoir cover (3), diaphragm plate (4) and diaphragm (5). Fill the reservoir with DOT 4 BRAKE FLUID from a sealed container up to the UPPER level mark (6). Reinstall the diaphragm, diaphragm plate and cover. Tighten the screws securely.

#### Other Checks:

Make sure there are no fluid leaks. Check for deterioration or cracks in the hoses and fittings.

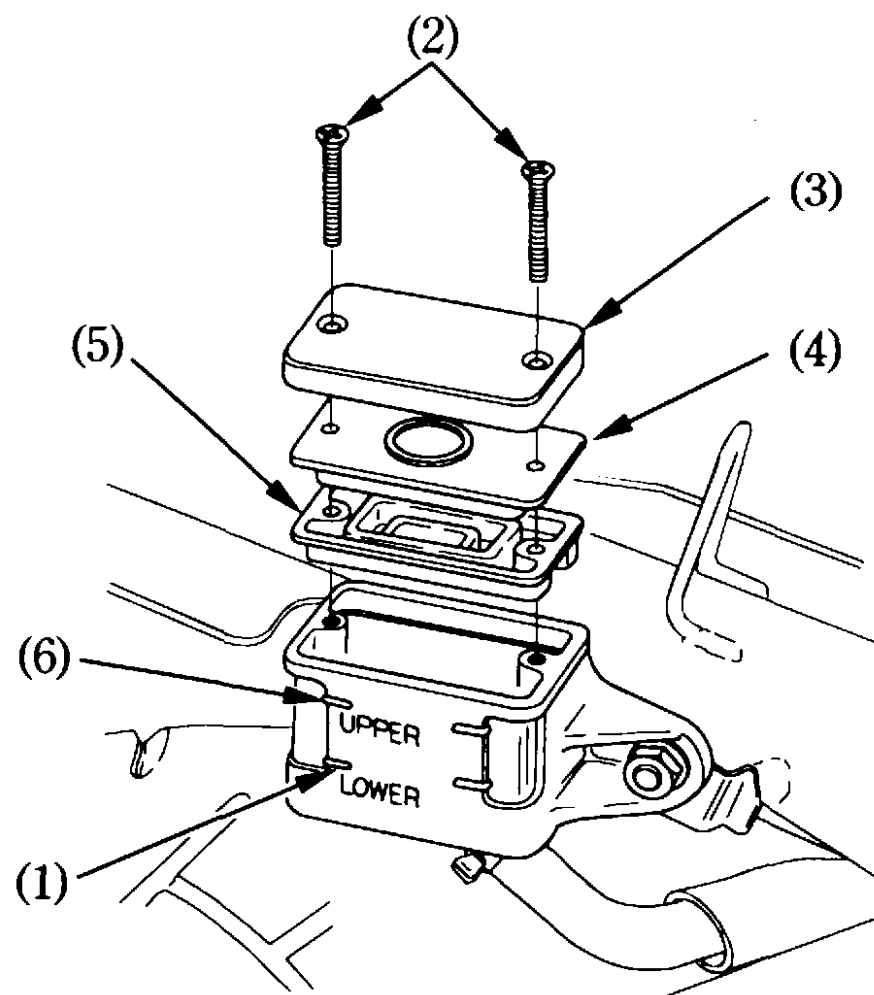

- |                      |                      |
|----------------------|----------------------|
| (1) LOWER level mark | (4) Diaphragm plate  |
| (2) Screw            | (5) Diaphragm        |
| (3) Reservoir cover  | (6) UPPER level mark |



## CLUTCH

This motorcycle has a hydraulically actuated clutch. There are no adjustments to perform but the clutch system must be inspected periodically for fluid level and leakage. If the control lever freeplay becomes excessive and the motorcycle creeps or stalls when shifted into gear, or if the clutch slips, causing acceleration to lag behind engine speed, there is probably air in the clutch system and it must be bled out. See your authorized Honda dealer for this service.

### Fluid level:

Check that the fluid level is above the LOWER level mark (1) with the motorcycle in an upright position. If the fluid level is near the lower level line, it indicates fluid leakage. See your authorized Honda dealer.

### Other Checks:

Make sure there are no fluid leaks. Check for deterioration or cracks in the hoses and fittings.

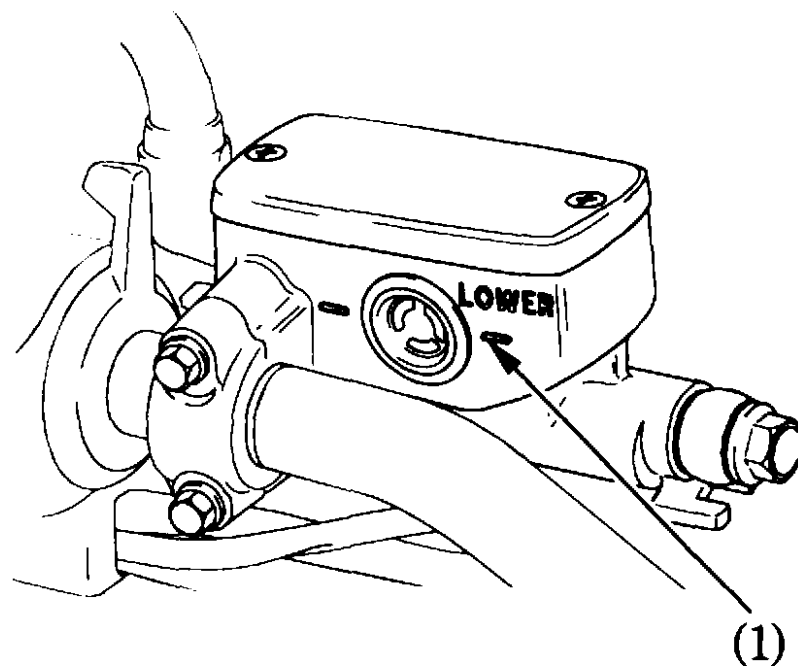

(1) LOWER level mark

## **COOLANT**

### **Coolant Recommendation**

The owner must properly maintain the coolant to prevent freezing, overheating, and corrosion. Use only high quality ethylene glycol antifreeze containing corrosion protection inhibitors specifically recommended for use in aluminum engines. (SEE ANTIFREEZE CONTAINER LABEL).

### **CAUTION:**

- \* Use only low-mineral drinking water or distilled water as a part of the antifreeze solution. Water that is high in mineral content or salt may be harmful to the aluminum engine.**

The factory provides a 50/50 solution of antifreeze and distilled water in this motorcycle. This coolant solution is recommended for most operating temperatures and provides good corrosion protection. A higher concentration of antifreeze decreases the cooling system performance and is recommended only when additional protection against freezing is needed. A concentration of less than 40/60 (40% antifreeze) will not provide proper corrosion protection. During freezing temperatures, check the cooling system frequently and add higher concentrations of antifreeze (up to a maximum of 60% antifreeze) if required.

## Inspection

The reserve tank is behind the left side cover.

Check the coolant level in the reserve tank (1) while the engine is at the normal operating temperature with the motorcycle in an upright position. If the coolant level is below the LOWER level mark (2), remove the left side cover (page 37) and the reserve tank cap (3). Add coolant mixture until it reaches the UPPER level mark (4). Do not remove the radiator cap.

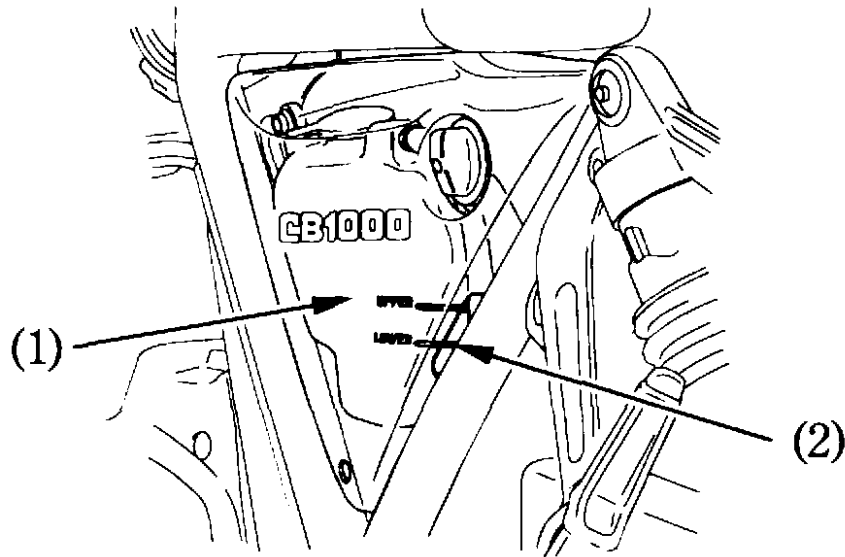

- (1) Reserve tank
- (2) LOWER level mark

## ⚠ WARNING

- \* Do not remove the radiator cap when the engine is hot. The coolant is under pressure and could scald you.
- \* Keep hands and clothing away from the cooling fan, as it starts automatically.

If the reserve tank is empty, or if coolant loss is excessive, check for leaks and see your authorized Honda dealer for repair.

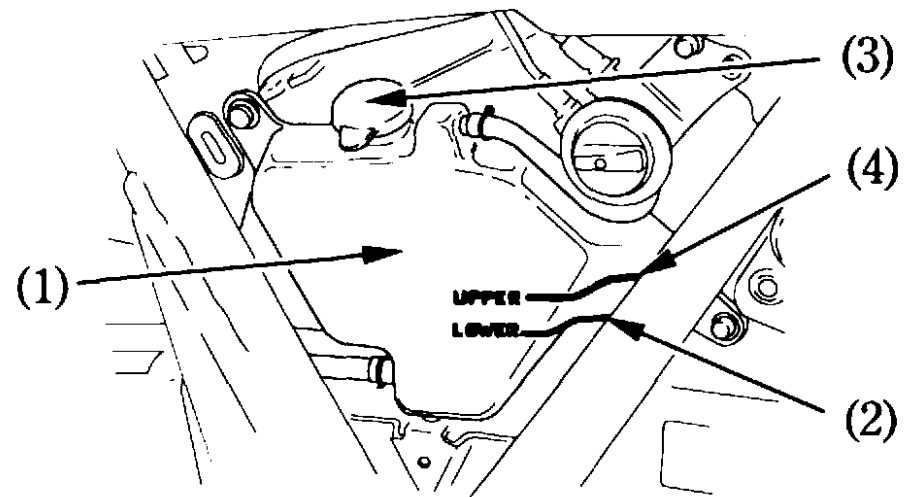

- (3) Reserve tank cap
- (4) UPPER level mark

## FUEL

### Manual Fuel Cock

The manual fuel cock (1) is under the left side of the fuel tank. Set it to ON for normal operation or RES when you start to run out of the main fuel supply. The OFF setting is only for long term storage or servicing of fuel system components.

### Automatic Fuel ON-OFF

With the fuel cock set to ON (or RES) fuel flows to the carburetors only when the engine is being started or is running. A diaphragm shuts off fuel flow when the engine is turned off.

### Reserve Fuel

When the main fuel supply is gone, turn the fuel cock to RES. Refill the tank as soon as possible after switching to RES, then switch the cock back to ON.

The reserve fuel supply is:

4.0 ℓ (1.06 US gal , 0.88 Imp gal)

## ⚠ WARNING

- To avoid running out of fuel that may result in a sudden stop, learn how to operate the fuel cock when riding the motorcycle.

### NOTE:

- Remember to check that the fuel cock is in the ON position each time you refuel. If the cock is left in the RES position, you may run out of fuel with no reserve.

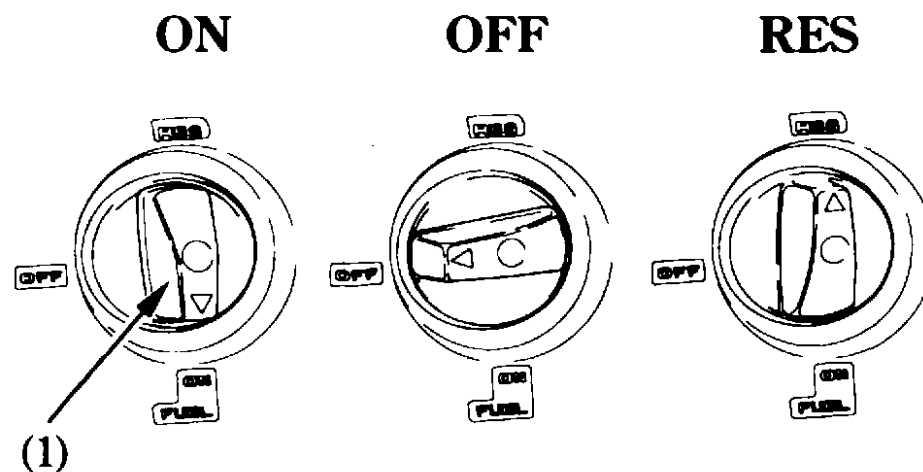

(1) Fuel cock lever

## Fuel Tank

The fuel tank capacity including the reserve supply is:

22 ℓ (5.8 US gal, 4.8 Imp gal)

To open the fuel fill cap (1), insert the ignition key (2), and turn it clockwise. The fuel fill cap is hinged and will lift up.

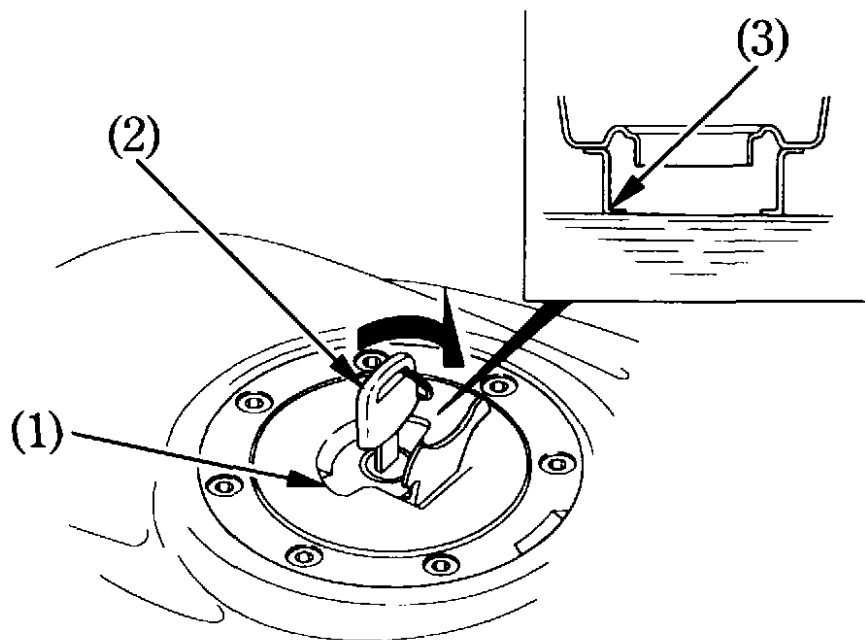

- (1) Fuel fill cap
- (2) Ignition key
- (3) Filler neck

After refueling, to close the fuel fill cap, push the fuel fill cap into the filler neck until it snaps closed and locks. Remove the key.

### Except AUSTRALIA:

Use unleaded or low-lead petrol with a research octane number of 91 or higher. We recommend that you use unleaded petrol because it produces fewer engine and spark plug deposits and extends the life of exhaust system components.

### For AUSTRALIA only

Use unleaded petrol with a research octane number of 91 or higher.

### CAUTION:

- \* If “spark knock” or “pinking” occurs at a steady engine speed under normal load, change brands of petrol. If spark knock or pinking persists, consult your authorized Honda dealer. Failure to do so is considered misuse, and damage caused by misuse is not covered by Honda’s Limited Warranty.

## **⚠ WARNING**

- \* Petrol is extremely flammable and is explosive under certain conditions. Refuel in a well-ventilated area with the engine stopped. Do not smoke or allow flames or sparks in the area where petrol is stored or where the fuel tank is refueled.
- \* Do not overfill the tank (there should be no fuel in the filler neck (3)). After refueling, make sure the fuel fill cap is closed securely.
- \* Be careful not to spill fuel when refueling. Spilled fuel or fuel vapor may ignite. If any fuel is spilled, make sure the area is dry before starting the engine.
- \* Avoid repeated or prolonged contact with skin or breathing of vapor. **KEEP OUT OF REACH OF CHILDREN.**

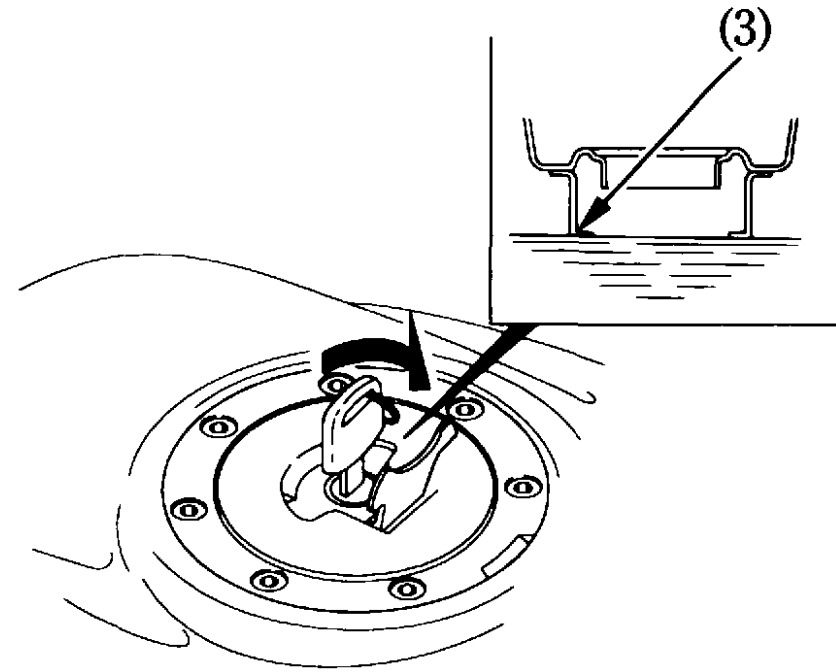

(3) Filler neck

## **Petrol Containing Alcohol**

If you decide to use a petrol containing alcohol (gasohol), be sure it's octane rating is at least as high as that recommended by Honda. There are two types of "gasohol": one containing ethanol, and the other containing methanol. Do not use petrol that contains more than 10% ethanol. Do not use petrol containing methanol (methyl or wood alcohol) that does not also contain cosolvents and corrosion inhibitors for methanol. Never use petrol containing more than 5% methanol, even if it has cosolvents and corrosion inhibitors.

## **NOTE:**

- \* Fuel system damage or engine performance problems resulting from the use of fuels that contain alcohol is not covered under the warranty. Honda cannot endorse the use of fuels containing methanol since evidence of their suitability is as yet incomplete.
- \* Before buying fuel from an unfamiliar station, try to find out if the fuel contains alcohol. If it does, confirm the type and percentage of alcohol used. If you notice any undesirable operating symptoms while using a petrol that contains alcohol, or one that you think contains alcohol, switch to a petrol that you know does not contain alcohol.

## ENGINE OIL

### Engine Oil Level Check

Check the engine oil level each day before riding the motorcycle.

The level must be maintained between the upper (1) and lower (2) level marks on the dipstick (3).

1. Start the engine and let it idle for a few minutes. Make sure the red low oil pressure indicator goes off. If the light remains on, stop the engine immediately.
2. Stop the engine and put the motorcycle on its center stand on level ground.
3. After a few minutes, remove the oil filler cap/dipstick, wipe it clean, and reinsert the dipstick without screwing it in. Remove the dipstick. The oil level should be between the upper and lower marks on the dipstick.
4. If required, add the specified oil (see page 56) up to the upper level mark. Do not overfill.
5. Reinstall the oil filler cap/dipstick. Check for oil leaks.

### CAUTION:

- \* **Running the engine with insufficient oil can cause serious engine damage.**

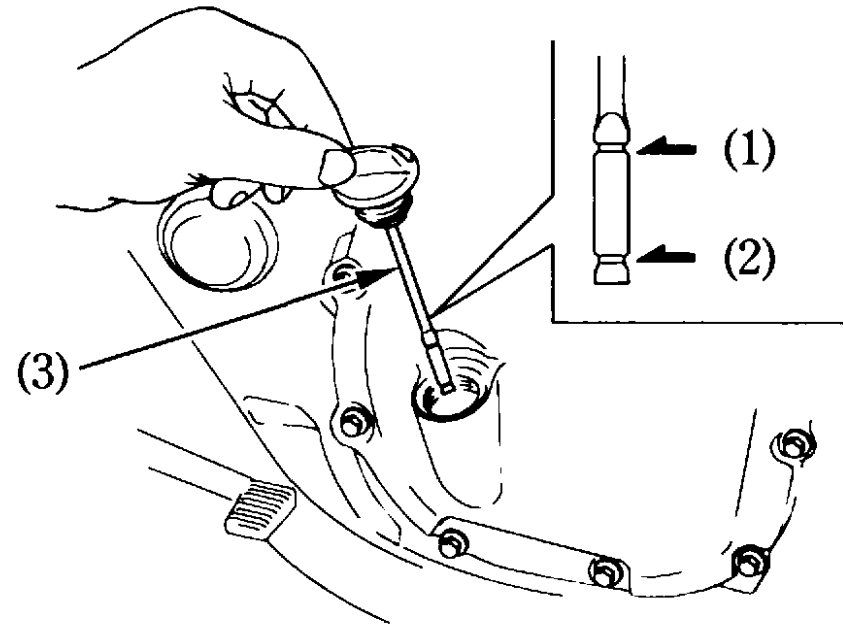

- (1) Upper level mark
- (2) Lower level mark
- (3) Oil filler cap/dipstick



## TUBELESS TYRES

This motorcycle is equipped with tubeless tyres, valves, and wheel rims. Use only tyres marked "TUBELESS" and tubeless valves on rims marked "TUBELESS TYRE APPLICABLE."

Proper air pressure will provide maximum stability, riding comfort and tyre life.

Check tyre pressure frequently and adjust if necessary.

### NOTE:

- \* Tyre pressure should be checked before you ride while the tyres are "cold".
- \* Tubeless tyres have some degree of selfsealing ability if they are punctured, and leakage is often very slow. Inspect very closely for punctures, especially if the tyre is not fully inflated.

Tyre size		
Front	120/70R18 – 59V	
Rear	170/60R18 – 73V	
Cold tyre pressures kPa (kg/cm <sup>2</sup> , psi)	Driver only	
	Front	250 (2.50 , 36)
	Rear	290 (2.90 , 42)
	Driver and one passenger	
	Front	250 (2.50 , 36)
	Rear	290 (2.90 , 42)
Tyre brand TUBELESS ONLY	DUNLOP	
	Front	D202F
	Rear	D202

Check the tyres for cuts, embedded nails or other sharp objects. Check the rims for dents or deformation. If there is any damage, see your authorized Honda dealer for repair, replacement, and balancing.

**⚠ WARNING**

- \* **Improper tyre inflation will cause abnormal tread wear and create a safety hazard. Underinflation may result in the tyre slipping on, or coming off of the rim causing tyre deflation that may result in a loss of vehicle control.**
- \* **Operation with excessively worn tyres is hazardous and will adversely affect traction and handling.**

Replace tyres before tread depth at the center of the tyre reaches the following limit:

Minimum tread depth	
Front :	1.5 mm (0.06 in)
Rear :	2.0 mm (0.08 in)

**NOTE:** < For Germany >

- \* German law prohibits use of tyres whose tread depth is less than 1.6 mm.

## **Tyre Repair/Replacement:**

See your authorized Honda Dealer.

### **⚠ WARNING**

- \* The use of tyres other than those listed on the tyre information label may adversely affect handling.
- \* Do not install tube-type tyres on tubeless rims. The beads may not seat and the tyres could slip on the rims, causing tyre deflation that may result in a loss of vehicle control.
- \* Do not install a tube inside a tubeless tyre. Excessive heat build-up may cause the tube to burst resulting in rapid tyre deflation that may result in a loss of vehicle control.
- \* Proper wheel balance is necessary for safe, stable handling of the motorcycle. Do not remove or change any wheel balance weights. When wheel balancing is required, see your authorized Honda dealer. Wheel balancing is required after tyre repair or replacement.

### **⚠ WARNING**

- \* To avoid possible repair failure and tyre deflation that may result in a loss of vehicle control, do not exceed 60 km/h (40 mph) for the first 24 hours, or 130 km/h (80 mph) at any time, after tyre repair.
- \* Replace the tyre if the sidewall is punctured or damaged. Sidewall flexing may cause repair failure and tyre deflation that may result in a loss of vehicle control.

### **CAUTION:**

- \* Do not try to remove tubeless tyres without special tools and rim protectors. You may damage the rim sealing surface or disfigure the rim.

# ESSENTIAL INDIVIDUAL COMPONENTS

## IGNITION SWITCH

The ignition switch (1) is below the indicator panel.

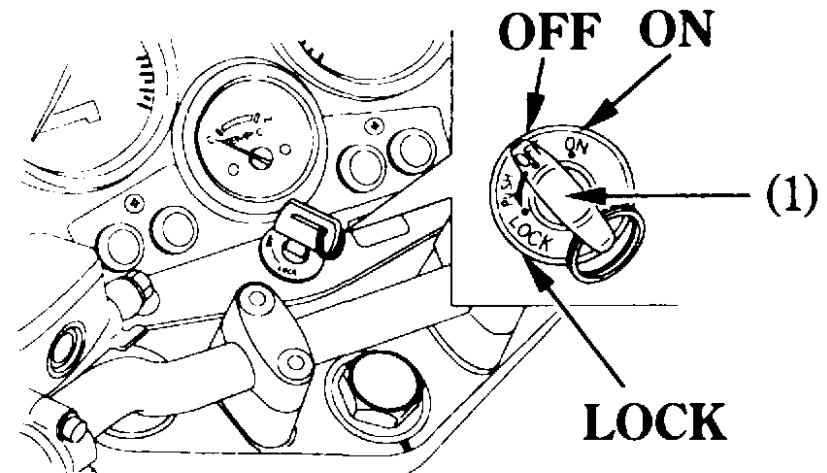

(1) Ignition switch

Key Position	Function	Key Removal
LOCK (steering lock)	Steering is locked. Engine and lights cannot be operated.	Key can be removed
P (parking) < AR Type >	For parking the motorcycle near traffic. The taillight and position light are on, but all other lights are off. The engine cannot be started.	Key can be removed
OFF	Engine and lights cannot be operated.	Key can be removed
ON	Engine and lights can be operated.	Key cannot be removed

## RIGHT HANDLEBAR CONTROLS

〈 Except AUSTRALIA 〉

### Engine Stop Switch

The engine stop switch (1) is next to the throttle grip. When the switch is in the RUN position, the engine will operate. When the switch is in the OFF position, the engine will not operate. This switch is intended primarily as a safety or emergency switch and should normally remain in the RUN position.

### Headlight Switch

The headlight switch (2) has three positions; “H”, “P” and “OFF” marked by a dot to the right of “P”.

H: Headlight, taillight, position light and meter lights on.

P: Position light, taillight and meter lights on.

OFF (dot): Headlight, taillight, position light and meter lights off.

### Starter Button

The starter button (3) is below the headlight switch (2).

When the starter button is pressed, the starter motor cranks the engine. If the engine stop switch is in the OFF position, the starter motor will not operate. See page 41 for the starting procedure.

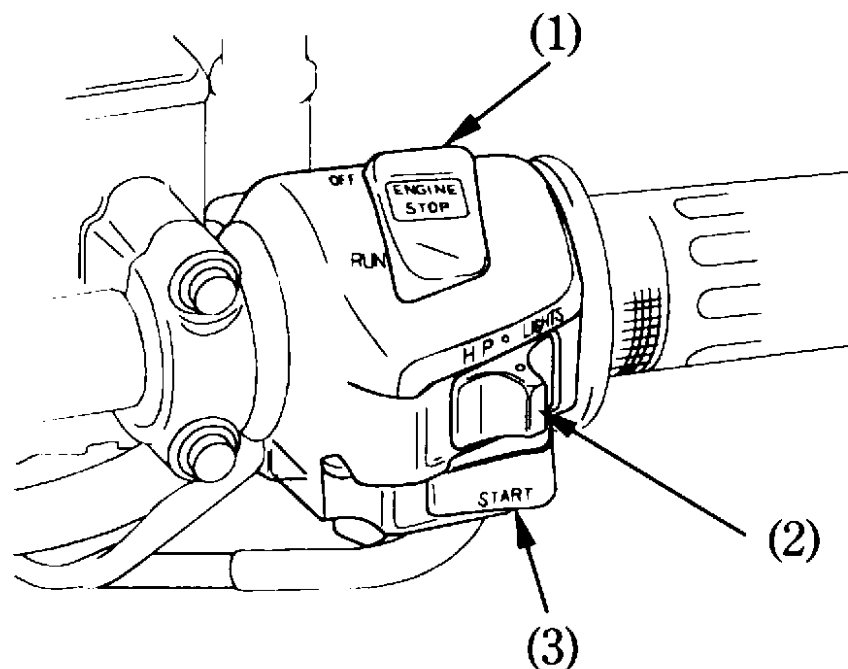

- (1) Engine stop switch
- (2) Headlight switch
- (3) Starter button

## RIGHT HANDLEBAR CONTROLS

〈 For AUSTRALIA only 〉

### Engine Stop Switch

The engine stop switch (1) is next to the throttle grip. When the switch is in the RUN position, the engine will operate. When the switch is in the OFF position, the engine will not operate. This switch is intended primarily as a safety or emergency switch and should normally remain in the RUN position.

### Starter Button

The starter button (2) is below the engine stop switch (1).

When the starter button is pressed, the starter motor cranks the engine. If the engine stop switch is in the OFF position, the starter motor will not operate. See page 41 for the starting procedure.

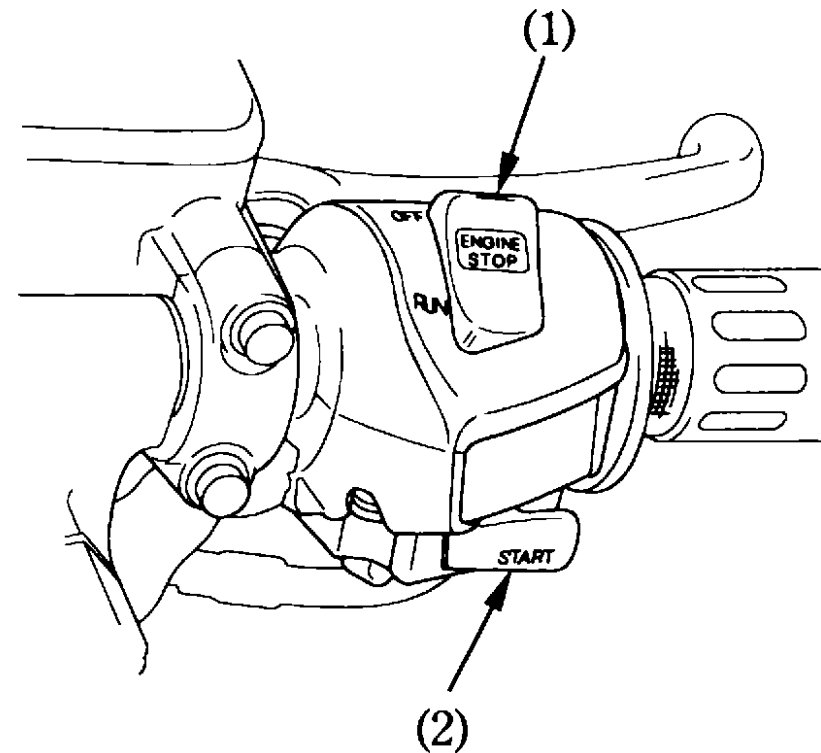

- (1) Engine stop switch
- (2) Starter button

## LEFT HANDLEBAR CONTROLS

### Headlight Dimmer Switch (1)

Push the dimmer switch to “HI” to select high beam or to “LO” to select low beam.

### Passing Light Control Switch (2)

When this switch is pressed, the headlight flashes on to signal approaching cars or when passing.

### Turn Signal Switch (3)

Move to L to signal a left turn, R to signal a right turn. Press to turn signal off.

### Horn Button (4)

Press the button to sound the horn.

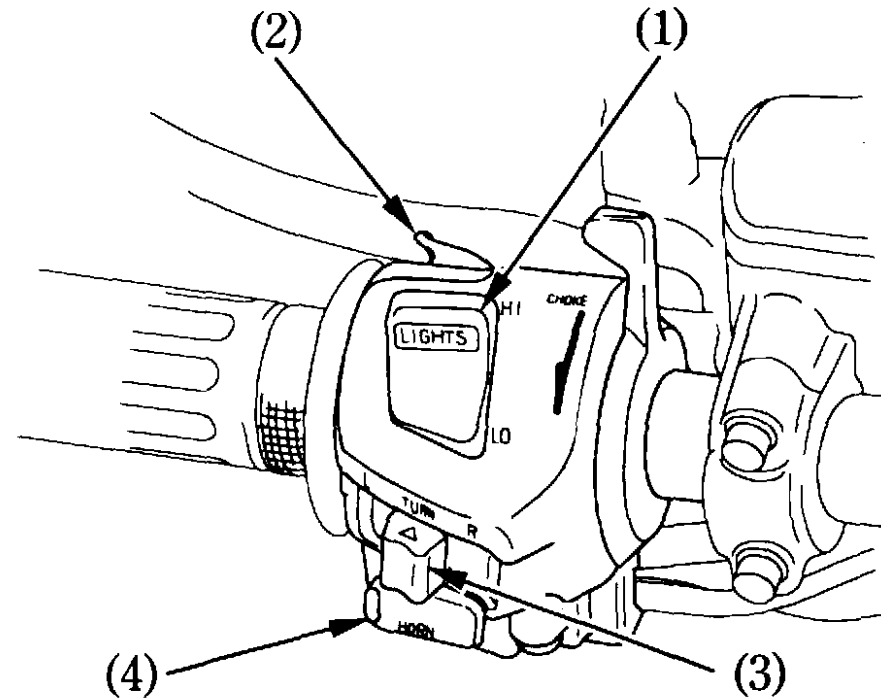

- (1) Headlight dimmer switch
- (2) Passing light control switch
- (3) Turn signal switch
- (4) Horn button

## FEATURES

(Not required for operation)

### STEERING LOCK

To lock the steering, turn the handlebars all the way to the left or right, turn the key (1) to P or LOCK while pushing in. Remove the key.

#### **⚠ WARNING**

\* Do not turn the key to P or LOCK while riding the motorcycle; loss of vehicle control will result.

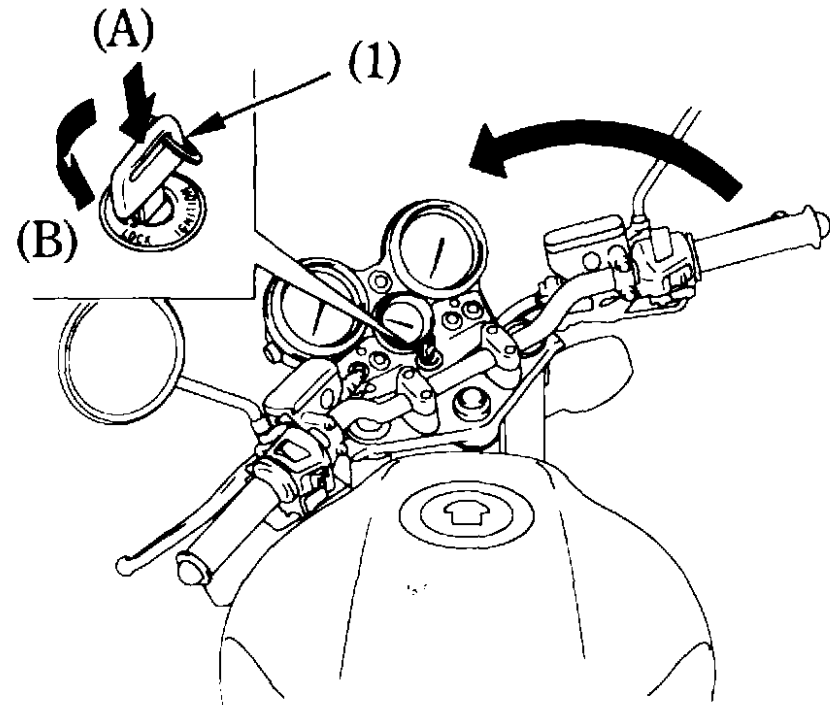

(1) Ignition key

(A) Push in

(B) Turn to LOCK



## HELMET HOLDER

The helmet holder (1) is on the left side below the seat. Insert the ignition key (2) and turn it clockwise to unlock. Hang your helmet on the holder pin (3). Turn the key counterclockwise to lock the holder and then remove the key.

### **▲WARNING**

- \* The helmet holder is designed for helmet security while parked. Do not ride with a helmet attached to the holder; the helmet may interfere with safe operation and result in loss of control.
- \* As the helmet holder and seat lock are combined, confirm that locking is properly completed by lifting up the seat after using helmet holder.

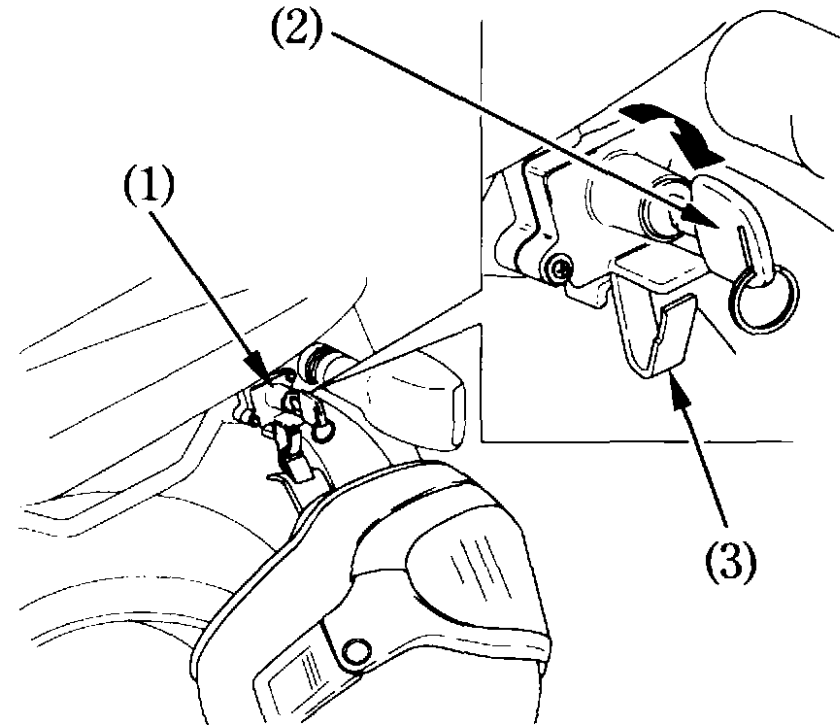

(1) Helmet holder  
(2) Ignition key

(3) Holder pin

## SEAT

To remove the seat (1), insert the ignition key (2) into the lock (3) and turn it clockwise.

Pull the seat lock lever (4) downward to unlock the seat.

### CAUTION:

**\* Be sure the seat is locked securely in position after installation.**

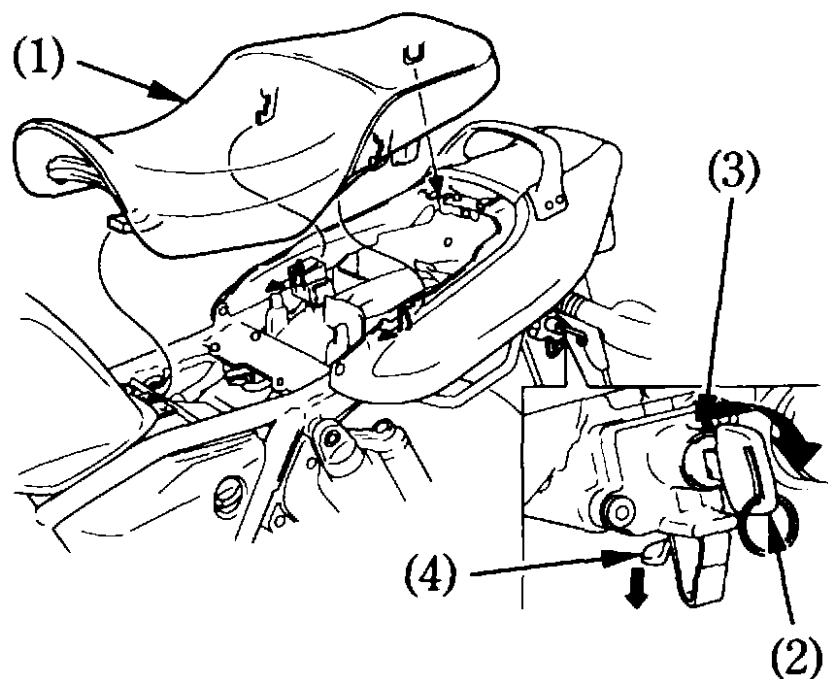

(1) Seat

(2) Ignition key

(3) Lock

(4) Seat lock lever

## DOCUMENT COMPARTMENT

The document bag (1) is in the document compartment (2) on the reverse side of the seat (3).

This owner's manual and other documents should be stored in this compartment.

When washing your motorcycle, be careful not to flood this area with water.

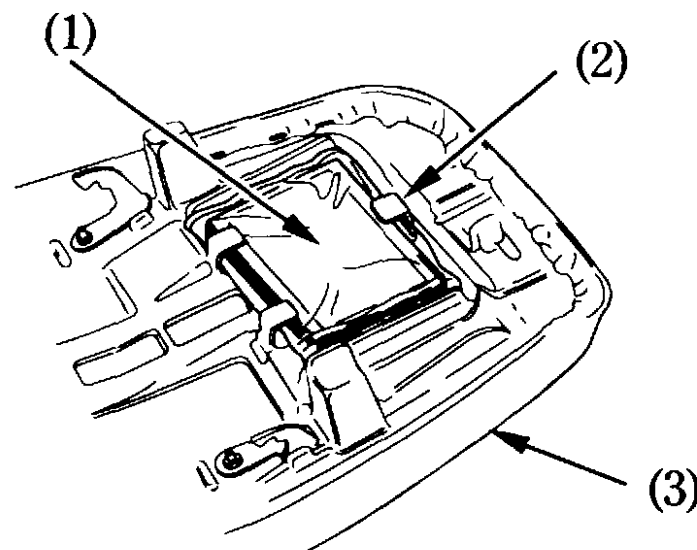

(1) Document bag

(2) Document compartment

(3) Seat

## SIDE COVER

To remove the right and left side covers (1), remove the screws (2) and then pull out the side cover by releasing the tabs (3).

### NOTE:

- \* Do not pull on the side cover with the screw (2) installed.

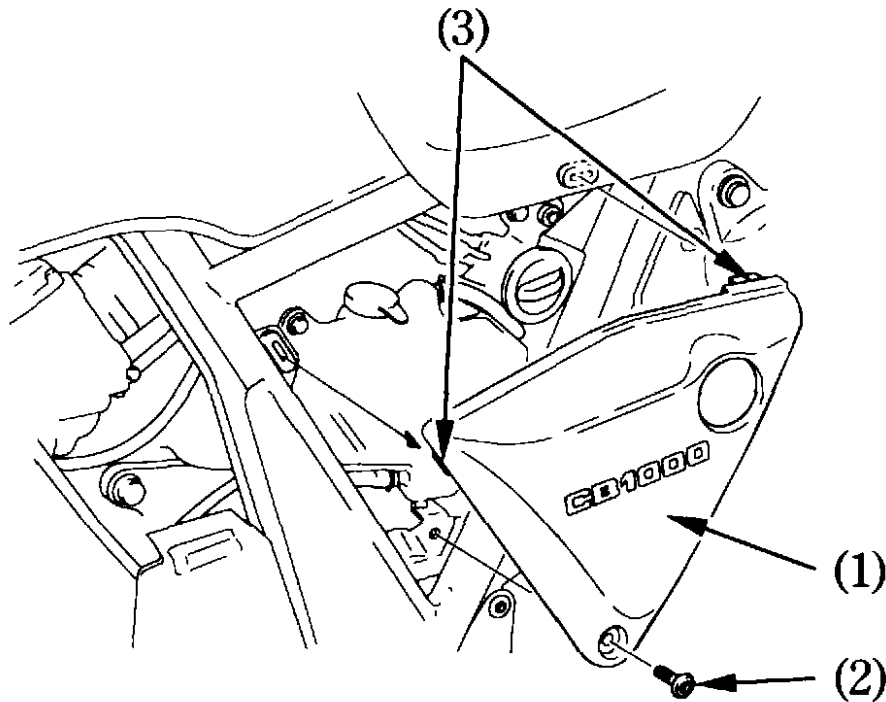

- (1) Side cover
- (2) Screw

- (3) Retaining tabs

## STORAGE COMPARTMENT

The storage compartment (1) is located under the seat.

This compartment is for light weight items. Do not carry more than 2.0 kg (4.4 lbs) in this compartment.

When washing your motorcycle, be careful not to flood this area with water.

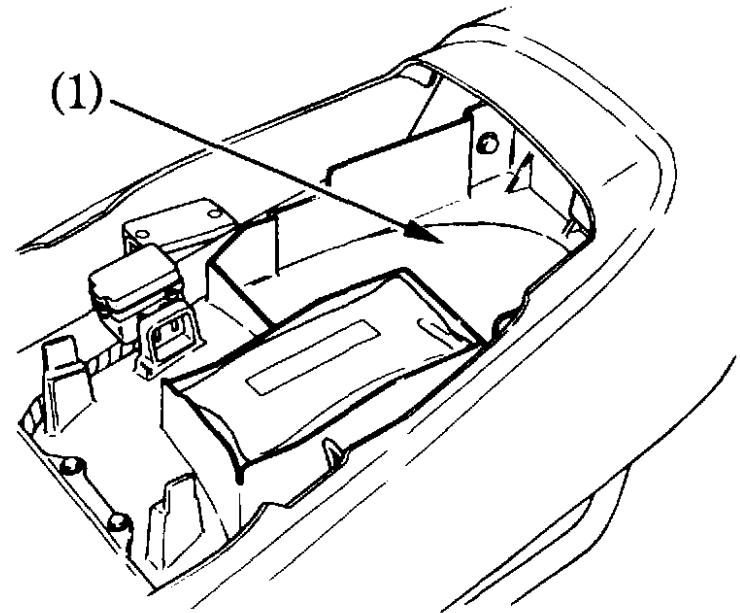

- (1) Storage compartment

## REAR COWL

To remove the rear cowl (1), remove the seat (page 36).

Remove the grab rail (2) by removing the bolts (3).

Remove the screws (4) and remove the rear cowl.

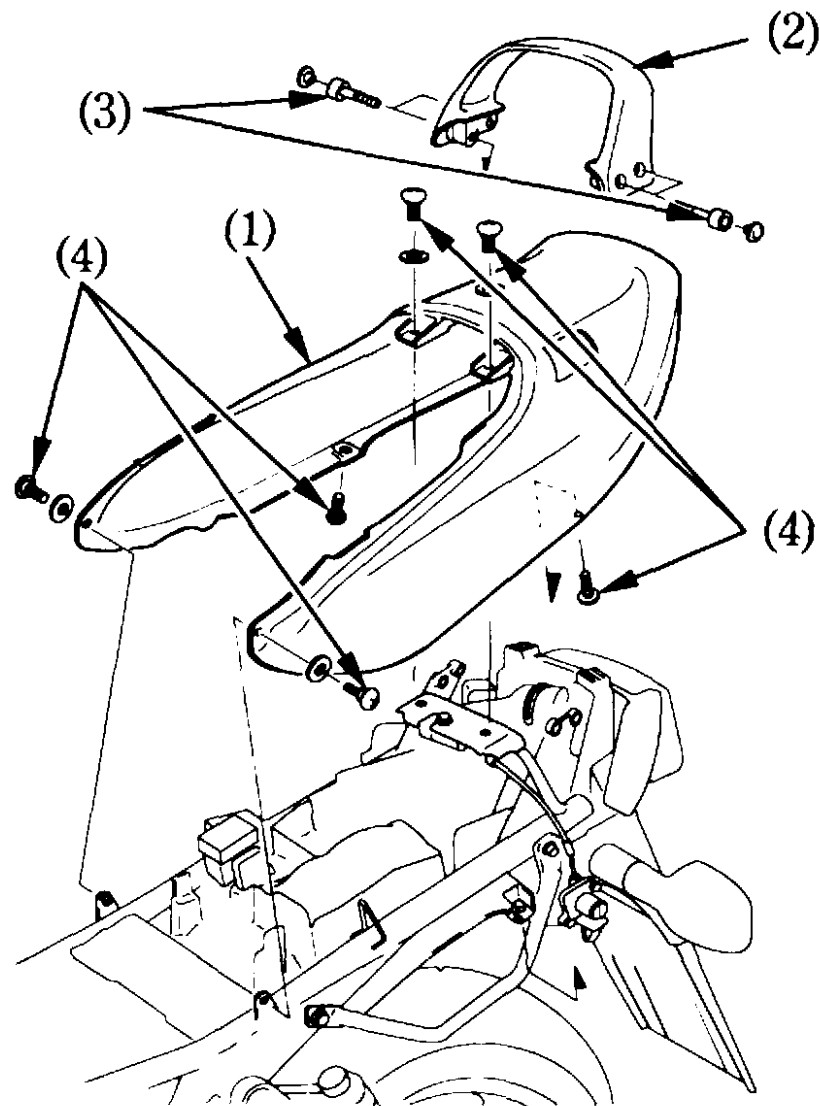

(1) Rear cowl  
(2) Grab rail

(3) Bolts  
(4) Screws

# OPERATION

## PRE-RIDE INSPECTION

### **▲WARNING**

**\* If the Pre-ride Inspection is not performed, severe personal injury or vehicle damage may result.**

Inspect your motorcycle every day before you ride it. The items listed here will only take a few minutes to inspect, and in the long run they can save time, expense, and possibly your life.

1. Engine oil level—add engine oil if required (page 26). Check for leaks.
2. Fuel level—fill fuel tank when necessary (page 23). Check for leaks.
3. Coolant level—add coolant if required. Check for leaks (pages 20–21).
4. Front and rear brakes—check operation; make sure there is no brake fluid leakage (pages 15–18).

5. Tyres—check condition and pressure (pages 27–29).
6. Drive chain—check condition and slack (page 66). Adjust and lubricate if necessary.
7. Throttle—check for smooth opening and full closing in all steering positions.
8. Lights and horn—check that headlight, tail/brake light, turn signals, indicators and horn function properly.
9. Engine stop switch—check for proper function (page 31).
10. Side stand ignition cut-off system—check for proper function (page 72).

Correct any discrepancy before you ride. Contact your authorized Honda dealer for assistance if you cannot correct the problem.

## **STARTING THE ENGINE**

This motorcycle is equipped with a side stand ignition cut-off system. The engine cannot be started if the side stand is down, unless the transmission is in neutral. If the side stand is up, the engine can be started in neutral or in gear with the clutch lever pulled in. After starting with the side stand down, the engine will shut off if the transmission is put in gear before raising the side stand.

### **▲WARNING**

- \* **Never run the engine in an enclosed area. The exhaust contains poisonous carbon monoxide gas that can cause loss of consciousness and lead to death.**

### **NOTE:**

- \* Do not use the electric starter for more than 5 seconds at a time. Release the starter button for approximately 10 seconds before pressing it again.

## **Preparation**

Before starting, insert the key, turn the ignition switch ON and confirm the following:

- The transmission is in NEUTRAL (neutral indicator light ON).
- The engine stop switch is at RUN.
- The red low oil pressure indicator is ON.
- The fuel cock is ON.

## Starting Procedure

To restart a warm engine, follow the procedure for “High Air Temperature.”

### Normal Air Temperature

10° – 35° C (50° – 95° F)

1. Pull the choke lever (1) back all the way to Fully ON (A), if the engine is cold.
2. Start the engine, leaving the throttle closed.

#### NOTE:

- \* Do not open the throttle when starting the engine with the choke ON. This will lean the mixture, resulting in hard starting.

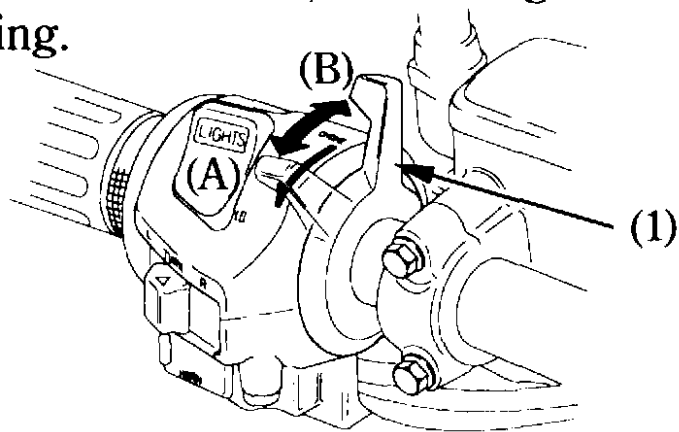

(1) Choke lever

(A) Fully ON

(B) Fully OFF

3. Immediately after the engine starts, operate the choke lever (1) to keep fast idle at:

2,000 – 3,000 min<sup>-1</sup> (rpm)

4. About a quarter minute after the engine starts, push the choke lever (1) forward all the way to Fully OFF (B).
5. If idling is unstable, open the throttle slightly.

#### CAUTION:

- \* The red low oil pressure indicator should go off a few seconds after the engine starts. If the light stays on, stop the engine immediately and check engine oil level. Operating the engine with insufficient oil pressure can cause serious engine damage.

## High Air Temperature

35° C (95° F) or above

1. Do not use the choke.
2. Open the throttle slightly.
3. Start the engine.

## Low Air Temperature

10° C (50° F) or below

1. Follow steps 1 – 2 under “Normal Air Temperature.”
2. When engine speed begins to pick up, operate the choke lever to keep fast idle at :  
2,000 – 3,000 min<sup>-1</sup> (rpm)
3. Continue warming up the engine until it runs smoothly and responds to the throttle when the choke lever (1) is at Fully OFF (B).



## **Flooded Engine**

If the engine fails to start after repeated attempts, it may be flooded with excess fuel. To clear a flooded engine, leave the engine stop switch on RUN and push the choke lever forward to Fully OFF (B). Open the throttle fully and crank the engine for 5 seconds. If the engine starts, quickly close the throttle, then open it slightly if idling is unstable. If the engine does not start, wait 10 seconds, then follow the Starting Procedure.

## **RUNNING-IN**

During initial running-in newly machined surfaces will be in contact with each other and these surfaces will wear in quickly. Running-in maintenance at 1,000km (600 miles) is designed to compensate for this initial minor wear. Timely performance of the running-in maintenance will ensure optimum service life and performance from the engine.

The general rules as follows:

1. Never labour the engine with full throttle at low engine speeds. This rule is applicable not only during running-in but at all times.
2. Maximum continuous engine speed during the first 1,000 km ( 600 miles) must not exceed 5,000  $\text{min}^{-1}$  (rpm).
3. Increase the maximum continuous engine speed by 2,000  $\text{min}^{-1}$  (rpm) between odometer readings of 1,000 km ( 600 miles) and 1,600 km (1,000 miles). Drive briskly, vary speeds frequently and use full throttle for short bursts only. Do not exceed 7,000  $\text{min}^{-1}$  (rpm).

4. Upon reaching an odometer reading of 1,600 km (1,000 miles), you can subject the motorcycle to full throttle operation. However, do not exceed 9,000  $\text{min}^{-1}$  (rpm) at any time (tachometer red zone limit).

### **CAUTION:**

- \* **Running the engine beyond recommended maximum engine speed (tachometer red zone) can damage the engine.**

## RIDING

### **▲WARNING**

- \* **Review Motorcycle Safety (pages 1 – 6 ) before you ride.**

### NOTE:

- \* Make sure you understand the function of the side stand mechanism. (See MAINTENANCE SCHEDULE on page 50 and explanation for SIDE STAND on page 72 )
1. After the engine has been warmed up, the motorcycle is ready for riding.
  2. While the engine is idling, pull in the clutch lever and depress the gearshift pedal to shift into 1st (low) gear.
  3. Slowly release the clutch lever and at the same time gradually increase engine speed by opening the throttle. Coordination of the throttle and clutch lever will assure a smooth positive start.

4. When the motorcycle attains a moderate speed, close the throttle, pull in the clutch lever and shift to 2nd gear by raising the gearshift pedal.

This sequence is repeated to progressively shift to 3rd, 4th and 5th (top) gears.

5. Coordinate the throttle and brakes for smooth deceleration.
6. Both front and rear brakes should be used at the same time and should not be applied strongly enough to lock the wheel, or braking effectiveness will be reduced and control of the motorcycle be difficult.

## **BRAKING**

1. For normal braking, gradually apply both the front and rear brakes while downshifting to suit your road speed.
2. For maximum deceleration, close the throttle and apply the front and rear brakes firmly. Pull in the clutch lever before coming to a complete stop to prevent stalling the engine.

### **⚠ WARNING**

- \* Independent use of only the front or rear brake reduces stopping performance. Extreme braking may cause either wheel to lock, reducing control of the motorcycle.
- \* When possible, reduce speed or brake before entering a turn; closing the throttle or braking in mid-turn may cause wheel slip. Wheel slip will reduce control of the motorcycle.

### **⚠ WARNING**

- \* When riding in wet or rainy conditions, or on loose surfaces, the ability to maneuver and stop will be reduced. All of your actions should be smooth under these conditions. Rapid acceleration, braking or turning may cause loss of control. For your safety, exercise extreme caution when braking, accelerating or turning.
- \* When descending a long, steep grade, use engine compression braking by downshifting, with intermittent use of both brakes. Continuous brake application can overheat the brakes and reduce their effectiveness.
- \* Riding with your foot resting on the brake pedal or your hands on the brake lever may actuate the brakelight, giving a false indication to other drivers. It may also overheat the brake, reducing effectiveness.

## **PARKING**

1. After stopping the motorcycle, shift the transmission into neutral, turn the fuel cock OFF, turn the handlebar fully to the left, turn the ignition switch OFF and remove the key.
2. Use the side or center stand to support the motorcycle while parked.

### **CAUTION:**

- \* **Park the motorcycle on firm, level ground to prevent it from falling over.**
  - \* **If you must park on a slight incline, aim the front of the motorcycle uphill to reduce the possibility of rolling off the side stand or overturning.**
3. Lock the steering to help prevent theft (page 34).

### **NOTE: <AR Type only >**

- \* When stopping for a short time near traffic at night, the ignition switch may be turned to P and the key removed. This will turn on the taillight to make the motorcycle more visible to traffic. The battery will discharge if the ignition switch is left at P for too long a time.

## **ANTI-THEFT TIPS**

1. Always lock the steering and never leave the key in the steering lock. This sounds simple but people do forget.
2. Be sure the registration information for your motorcycle is accurate and current.
3. Park your motorcycle in a locked garage whenever possible.
4. Use an additional anti-theft device of good quality.
5. Put your name, address, and phone number in this Owner's Manual and keep it on your motorcycle at all times. Many times stolen motorcycles are identified by information in the Owner's Manuals that are still with them.

NAME: \_\_\_\_\_

ADDRESS: \_\_\_\_\_

\_\_\_\_\_

\_\_\_\_\_

PHONE NO: \_\_\_\_\_

# MAINTENANCE

- The Required Maintenance Schedule specifies how often you should have your motorcycle served, and what things need attention. It is essential that your motorcycle be served as scheduled to retain its high level of safety, dependability, and emission control performance.
- These instructions are based on the assumption that the motorcycle will be used exclusively for its designed purpose. Sustained high speed operation, or operation in unusually wet or dusty conditions, will require more frequent service than specified in the MAINTENANCE SCHEDULE. Consult your authorized Honda dealer for recommendations applicable to your individual needs and use.

## MAINTENANCE SCHEDULE

The following Maintenance Schedule specifies all maintenance required to keep your motorcycle in peak operating condition. Maintenance work should be performed in accordance with standards and specifications of Honda by properly trained and equipped technicians. Your authorized Honda dealer meets all of these requirements.

Perform the Pre-ride Inspection (page 39) at each scheduled maintenance period.

I: INSPECT AND CLEAN, ADJUST, LUBRICATE OR REPLACE IF NECESSARY

C: CLEAN R: REPLACE A: ADJUST L: LUBRICATE

ITEM	FREQUENCY	WHICHEVER → COMES FIRST ↓ NOTE	ODOMETER READING [ NOTE (1) ]								REFER TO PAGE
			x 1,000 km	1	6	12	18	24	30	36	
			x 1,000 mi MONTH	0.6	4	8	12	16	20	24	
* FUEL LINE					I		I		I	—	
* THROTTLE OPERATION					I		I		I	63	
* CARBURETOR CHOKE					I		I		I	—	
AIR CLEANER		(NOTE 2)					R		R	65	
CRANKCASE BREATHER		(NOTE 3)		C	C	C	C	C	C	59	
* VALVE CLEARANCE			I		I		I		I	—	
SPARK PLUG				I	R	I	R	I	R	60	
ENGINE OIL			R		R		R		R	56	
ENGINE OIL FILTER			R		R		R		R	57	
* CARBURETOR SYNCHRONIZATION					I		I		I	—	
* ENGINE IDLE SPEED			I	I	I	I	I	I	I	64	
RADIATOR COOLANT		(NOTE 4)			I		I		R	20	
* COOLING SYSTEM					I		I		I	—	
* SECONDARY AIR SUPPLY SYSTEM		(NOTE 5)			I		I		I	—	



ITEM	FREQUENCY	WHICHEVER → COMES FIRST ↓ NOTE	ODOMETER READING [ NOTE (1) ]								REFER TO PAGE
			x 1,000 km	1	6	12	18	24	30	36	
			x 1,000 mi	0.6	4	8	12	16	20	24	
			MONTH		6	12	18	24	30	36	
	DRIVE CHAIN		EVERY 1,000km (600mi) I, L								66
	DRIVE CHAIN SLIDER				I		I		I		71
	BRAKE FLUID	(NOTE 4)			I	I	R	I	I	R	15
	BRAKE PADS WEAR				I	I	I	I	I	I	79
	BRAKE SYSTEM			I		I		I		I	15, 79
*	BRAKE LIGHT SWITCH					I		I		I	89
*	HEADLIGHT AIM					I		I		I	—
	CLUTCH SYSTEM					I		I		I	19
	CLUTCH FLUID	(NOTE 4)			I	I	R	I	I	R	19
	SIDE STAND					I		I		I	72
*	SUSPENSION					I		I		I	—
*	NUTS, BOLTS, FASTENERS			I		I		I		I	—
**	WHEELS / TYRES					I		I		I	—
**	STEERING HEAD BEARINGS			I		I		I		I	—

- \* SHOULD BE SERVICED BY YOUR AUTHORIZED HONDA DEALER, UNLESS THE OWNER HAS PROPER TOOLS AND SERVICE DATA AND IS MECHANICALLY QUALIFIED. REFER TO THE OFFICIAL HONDA SHOP MANUAL.
- \*\* IN THE INTEREST OF SAFETY, WE RECOMMEND THESE ITEMS BE SERVICED ONLY BY YOUR AUTHORIZED HONDA DEALER.

Honda recommends that your authorized Honda dealer should road test your motorcycle after each periodic maintenance is carried out.

- NOTES:
- (1) At higher odometer readings, repeat at the frequency interval established here.
  - (2) Service more frequently when riding in unusually wet or dusty areas.
  - (3) Service more frequently when riding in rain or at full throttle.
  - (4) Replace every 2 years, or at indicated odometer interval, whichever comes first. Replacement requires mechanical skill.
  - (5) Switzerland and Austria type only.

## **TOOL KIT**

Tool kit is under the seat.

Listed below are the items included in the tool kit (1).

- Tool bag
- 10 x 12 mm Box end wrench
- 22 mm Box end wrench
- 27 mm Box end wrench
- 8 mm Box end wrench
- 5 mm Hex wrench
- 6 mm Hex wrench
- 10 x 12 mm Open end wrench
- 14 x 17 mm Open end wrench
- Pin spanner
- Pliers
- No. 2 Phillips screwdriver
- No. 2 screwdriver
- Screwdriver handle
- Extension bar
- Spark plug wrench
- Feeler gauge 0.7 mm (0.03 in)

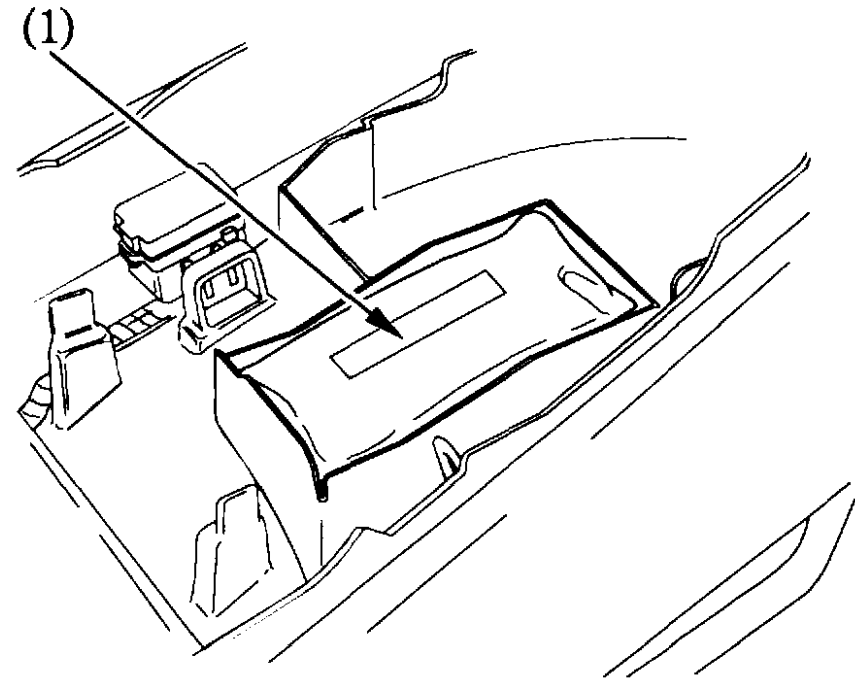

(1) Tool kit

## SERIAL NUMBERS

The frame and engine serial numbers are required when registering your motorcycle. They may also be required by your dealer when ordering replacement parts. Record the numbers here for your reference.

FRAME NO. \_\_\_\_\_

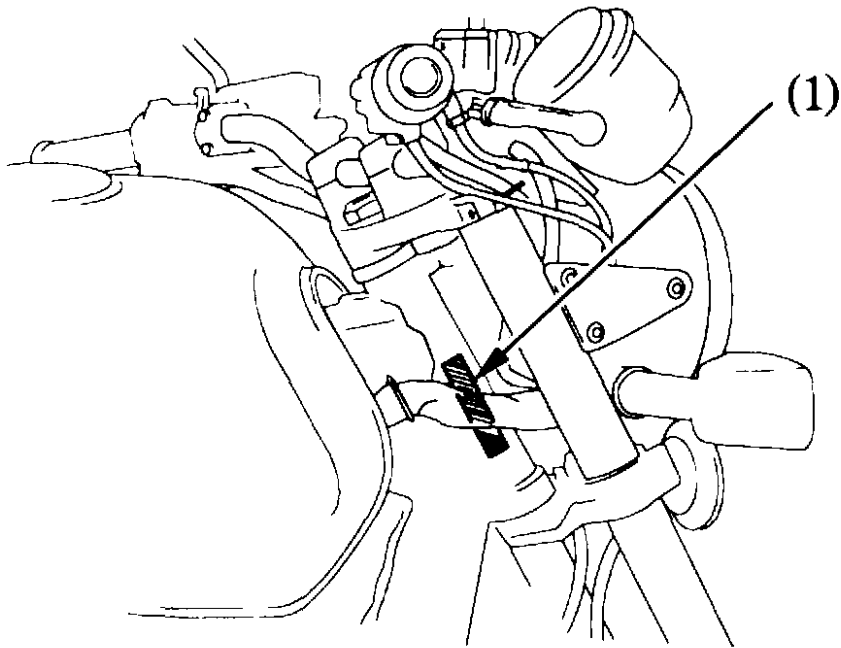

(1) Frame number

**54**

The frame number (1) is stamped on the right side of the steering head.

The engine number (2) is stamped on front of the crankcase.

ENGINE NO. \_\_\_\_\_

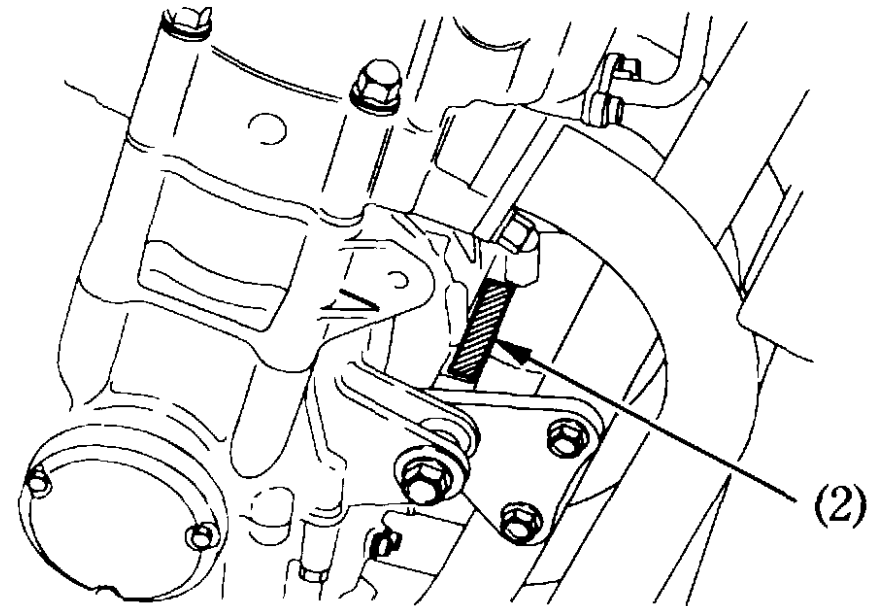

(2) Engine number

## COLOUR LABEL

The colour label (1) is attached to the fender below the seat.

It is helpful when ordering replacement parts. Record the colour and code here for your reference.

COLOUR \_\_\_\_\_

CODE \_\_\_\_\_

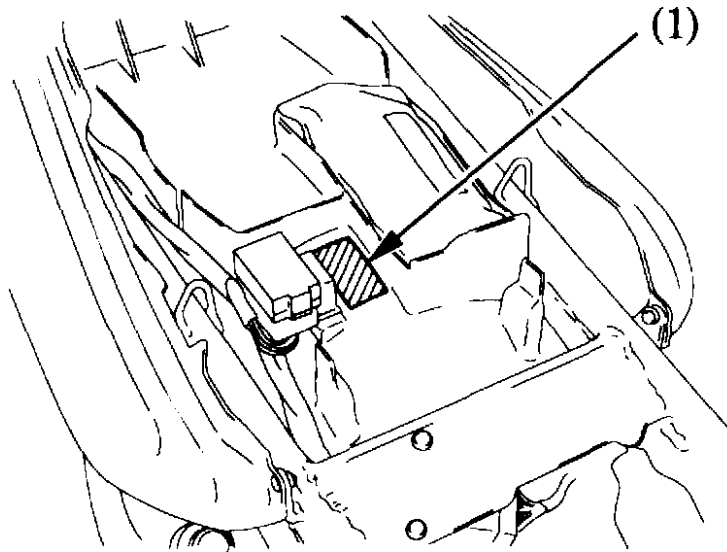

(1) Colour label

## MAINTENANCE PRECAUTIONS

### **▲WARNING**

- \* If your motorcycle is overturned or involved in a collision, inspect control levers, cables, brake hoses, calipers, accessories, and other vital parts for damage. Do not ride the motorcycle if damage impairs safe operation. Have your authorized Honda dealer inspect the major components, including frame, suspension and steering parts, for misalignment and damage that you may not be able to detect.
- \* Stop the engine and support the motorcycle securely on a firm, level surface before performing any maintenance.
- \* Use new, genuine Honda parts or their equivalent for maintenance and repair. Parts which are not of equivalent quality may impair the safety of your motorcycle.

## ENGINE OIL

(Refer to the maintenance precautions on page 55).

### Engine Oil

Good engine oil has many desirable qualities. Use only high detergent, quality motor oil certified on the container to meet or exceed requirements for API Service Classification SE, SF or SG.

#### Viscosity:

Viscosity grade of engine oil should be based on average atmospheric temperature in your riding area. The following provides a guide to the selection of the proper grade or viscosity of oil to be used at various atmospheric temperatures.

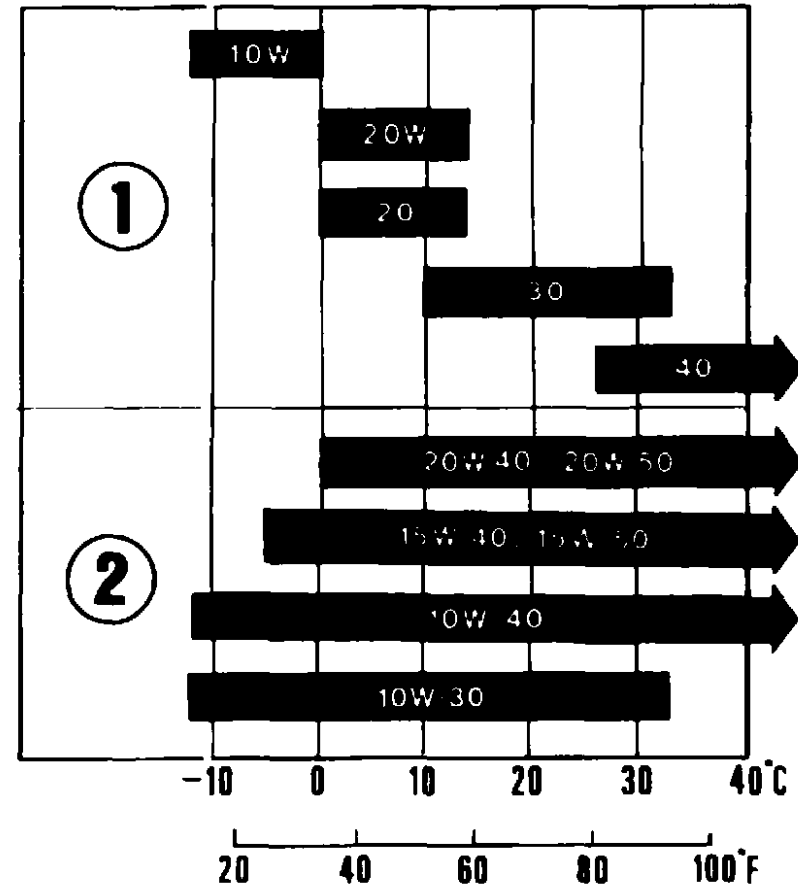

(1) Single grade

(2) Multi grade

## Engine Oil and Filter

Engine oil quality is the chief factor affecting engine service life. Change the engine oil as specified in the maintenance schedule (page 50).

Changing the oil filter requires a special oil filter tool and a torque wrench. If you do not have these tools and the necessary skill, we recommend that you have your authorized Honda dealer perform this service. If a torque wrench is not used for this installation, see your authorized Honda dealer as soon as possible to verify proper assembly.

### NOTE:

- \* Change the engine oil with the engine at normal operating temperature and the motorcycle on its side stand to assure complete and rapid draining.

### CAUTION:

- \* To prevent oil leaks and filter damage, never support the engine on the oil filter.

1. To drain the oil, remove the oil filler cap/dipstick and crankcase drain plug (1) and sealing washer (2).

### ▲WARNING

- \* A warmed-up engine and the oil in it are hot; be careful not to burn yourself.

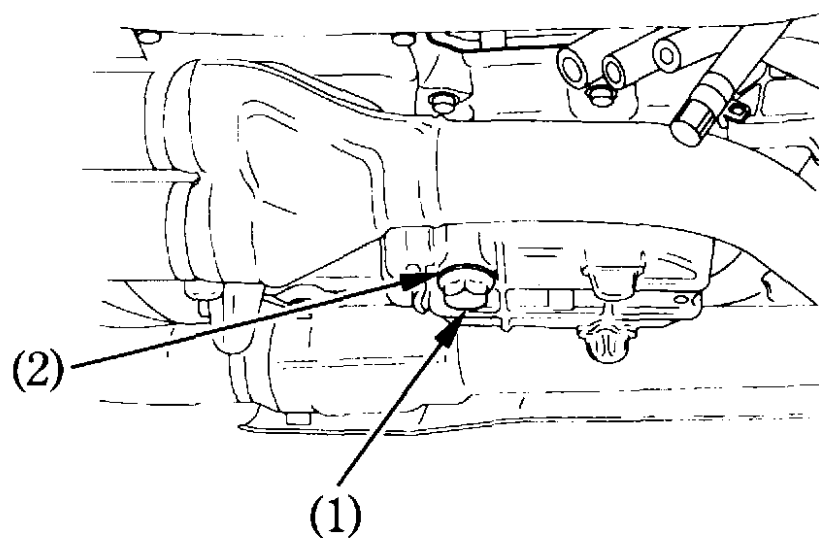

(1) Oil drain plug

(2) Sealing washer

2. Remove the oil filter (3) with a filter wrench and let the remaining oil drain out. Discard the oil filter (3).
3. Apply a thin coat of engine oil to the new oil filter rubber seal (4).
4. Using a special tool and a torque wrench, install the new oil filter and tighten to a torque of:  
10 N·m (1.0 kg-m , 7 lb-ft)
5. Use only the Honda genuine oil filter or a filter of equivalent quality specified for your model. Using the wrong Honda filter or a non-Honda filter which is not of equivalent quality may cause engine damage.

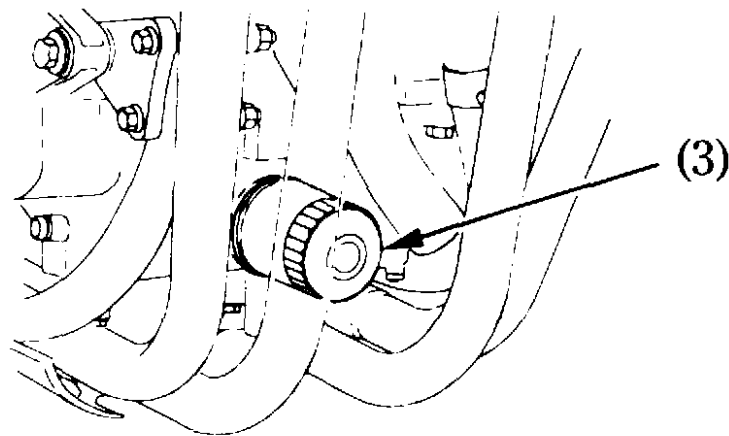

(3) Oil filter

6. Check that the sealing washer on the drain plug is in good condition and install the plug. Replace the sealing washer every other time the oil is changed, or each time if necessary.  
Oil Drain Plug Torque:  
30 N·m (3.0 kg-m , 22 lb-ft)
7. Fill the crankcase with the recommended grade oil; approximately:  
4.0 ℓ (4.2 US qt , 3.5 Imp qt)
8. Install the oil filler cap.
9. Start the engine and let it idle for 2–3 minutes.
10. Several minutes after stopping the engine, check that the oil level is at the upper level mark on the dipstick with the motorcycle upright on firm, level ground. Make sure there are no oil leaks.

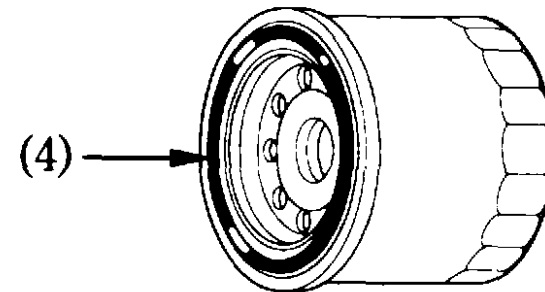

(4) Oil filter rubber seal



**NOTE:**

- \* When running in very dusty conditions, oil changes should be performed more frequently than specified in the maintenance schedule.
- \* Please dispose of used engine oil in a manner that is compatible with the environment. We suggest you take it in a sealed container to your local recycling center or service station for reclamation. Do not throw it in the rubbish or pour it on the ground or down a drain.

**CAUTION:**

- \* **Used engine oil may cause skin cancer if repeatedly left in contact with the skin for prolonged periods. Although this is unlikely unless you handle used oil on a daily basis, it is still advisable to thoroughly wash your hands with soap and water as soon as possible after handling used oil.**

**CRANKCASE BREATHER**

(Refer to the maintenance precautions on page 55).

1. Remove the crankcase breather tube plug (1) from the tube and drain deposits into a suitable container.
2. Reinstall the crankcase breather tube plug.

**NOTE:**

- \* Service more frequently when riding in rain or at full throttle.

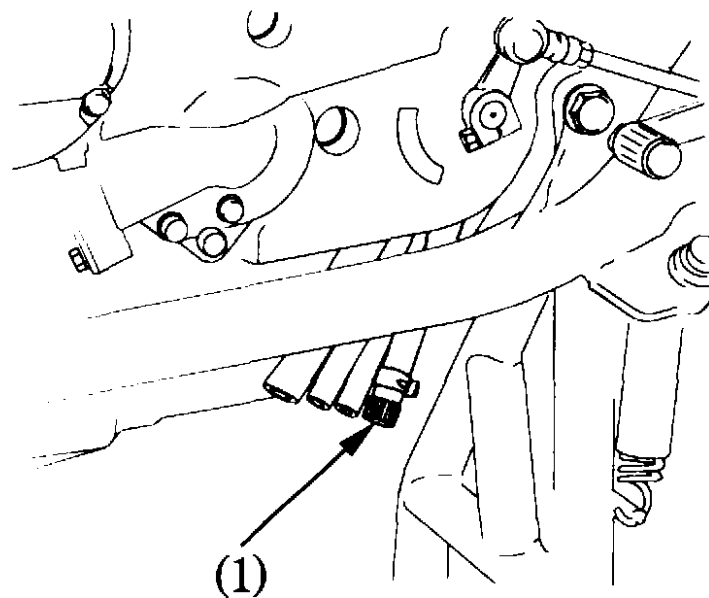

(1) Crankcase breather tube plug

## SPARK PLUGS

(Refer to the maintenance precautions on page 55).

Recommended plugs:

Standard:

DPR9EA-9 (NGK) or  
X27EPR-U9 (NIPPONDENSO)

To remove the spark plug:

1. Check that the fuel fill cap is closed.
2. Turn the fuel cock to OFF.
3. Remove the seat (page 36).
4. Remove the fuel tank mount bolts (1).
5. Slide the fuel tank (2) backward.

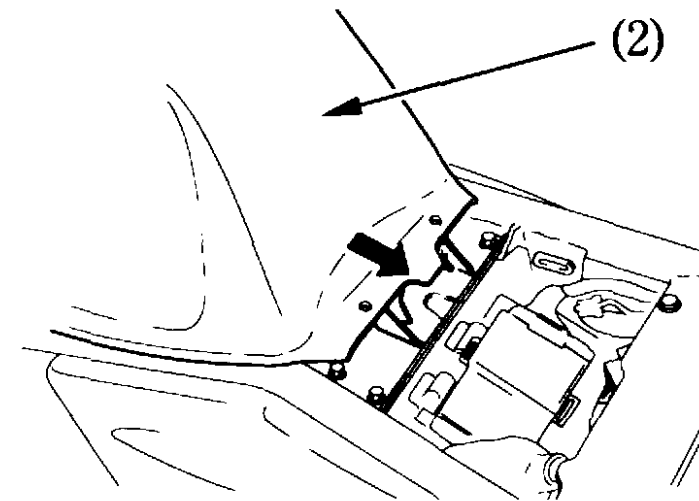
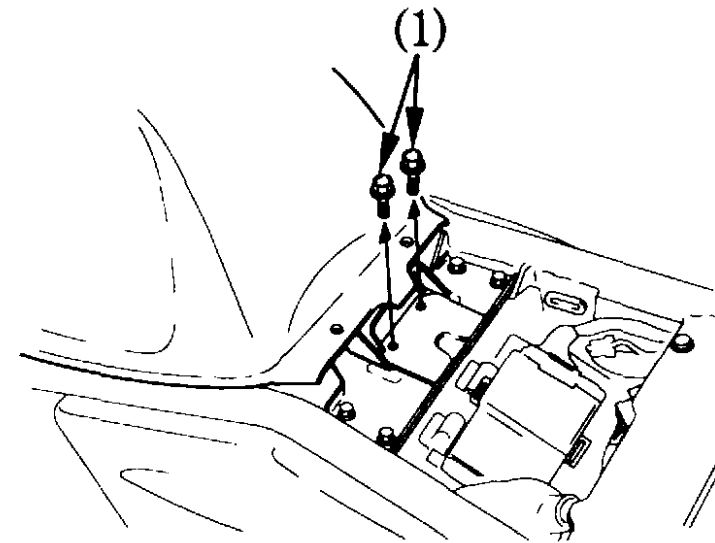

- (1) Mount bolts  
(2) Fuel tank

6. With the handlebar in straight ahead position, raise the front end of the fuel tank and support it with the fuel tank support rod (3).

**CAUTION:**

**\* Do not raise the fuel tank more than necessary.**

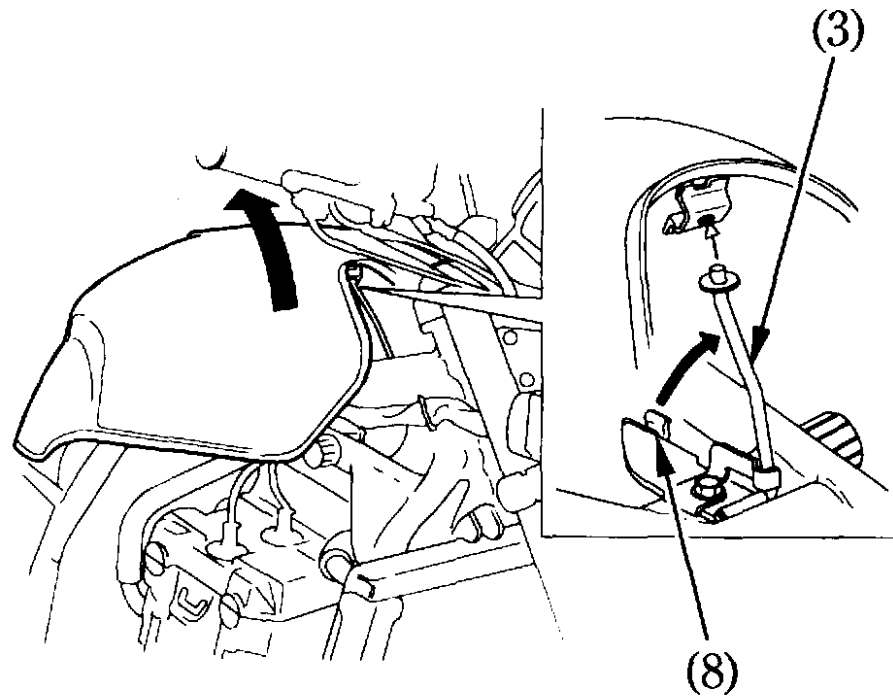

- (3) Fuel tank support rod
- (8) Rod holder

7. Disconnect the spark plug caps (4) from the spark plugs.

8. Clean any dirt from around the spark plug bases.

Remove the spark plugs using the spark plug wrench (5) furnished in the tool kit.

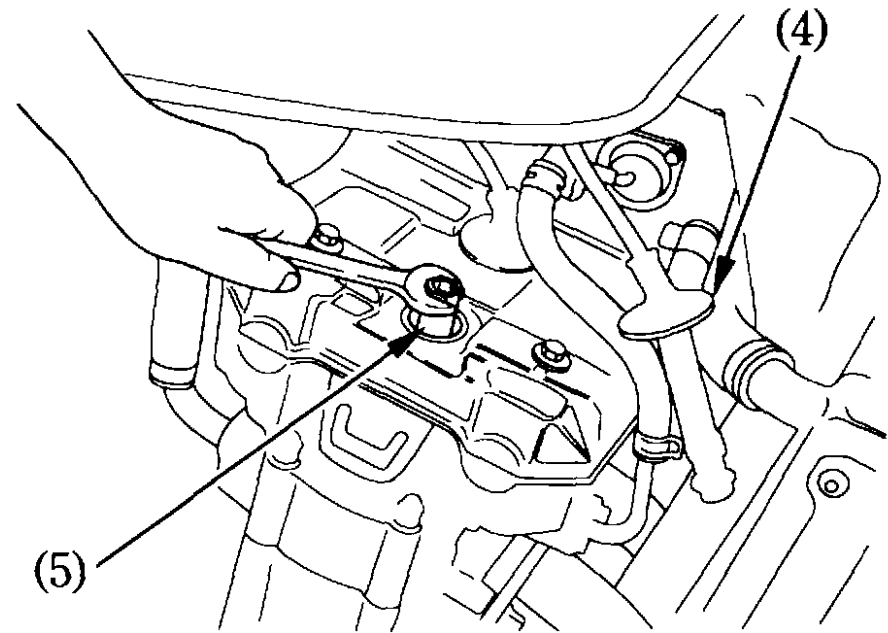

- (4) Spark plug cap
- (5) Spark plug wrench

9. Inspect the electrodes and center porcelain for deposits, erosion or carbon fouling. If the erosion or deposit is heavy, replace the plug. Clean a carbon or wet-fouled plug with a plug cleaner, otherwise use a wire brush.
10. Check the spark plug gap (6) using a wire-type feeler gauge. If adjustment is necessary, bend the side electrode (7) carefully.

The gap should be:

0.8–0.9 mm (0.03–0.04 in)

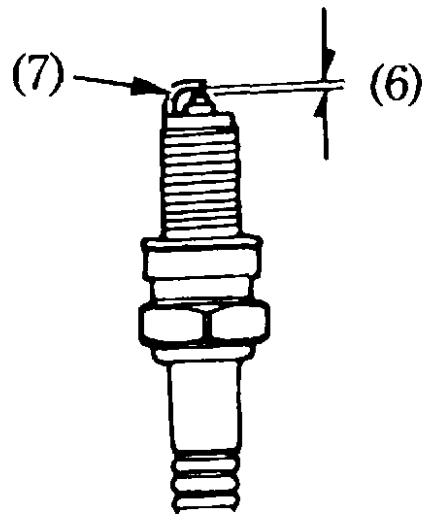

(6) Spark plug gap

(7) Side electrode

11. With the plug washer attached, thread the spark plug in by hand to prevent cross-threading.
12. Tighten the spark plug 1/2 turn with a spark plug wrench to compress the washer.
13. Reinstall the spark plug caps.

**CAUTION:**

- **The spark plug must be securely tightened. An improperly tightened plug can become very hot and possibly damage the engine.**
- **Never use a spark plug with an improper heat range. Severe engine damage could result.**

14. Secure the fuel tank.  
To secure the fuel tank, reverse the foregoing raising procedure.
  - Set the fuel tank support rod in the rod holder (8) securely.
  - Tighten the fuel tank mount bolts securely.

## THROTTLE OPERATION

(Refer to the maintenance precautions on page 55).

1. Check for smooth rotation of the throttle grip from the fully open to the fully closed position at both full steering positions.

2. Measure the throttle grip free play at the throttle grip flange.

The standard free play should be approx:

2–6 mm (0.1–0.2 in)

To adjust the free play, loosen the lock nut (1) and turn the adjuster (2).

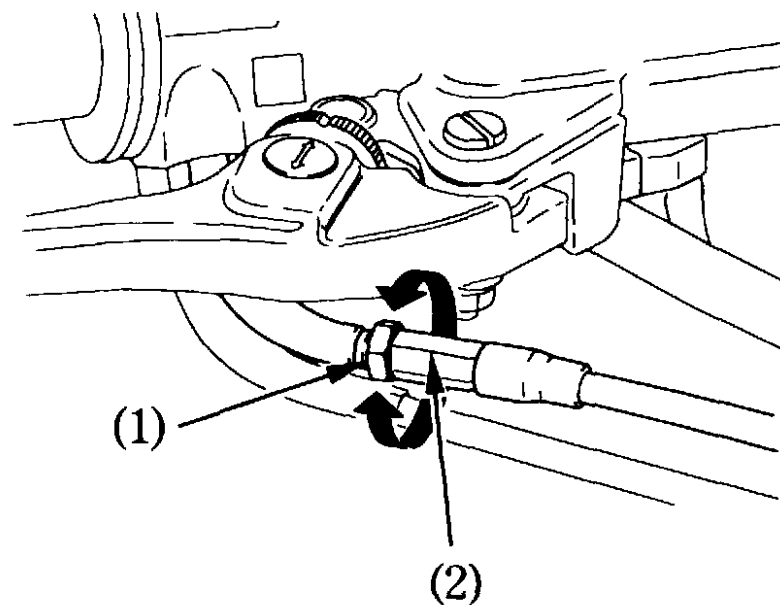

(1) Lock nut

(2) Adjuster



## AIR CLEANER

(Refer to the maintenance precautions on page 55).

The air cleaner should be serviced at regular intervals (page 50). Service more frequently when riding in unusually wet or dusty areas.

1. Remove the right side cover (page 37).
2. Remove the attaching screws (1) and air cleaner housing cover (2).

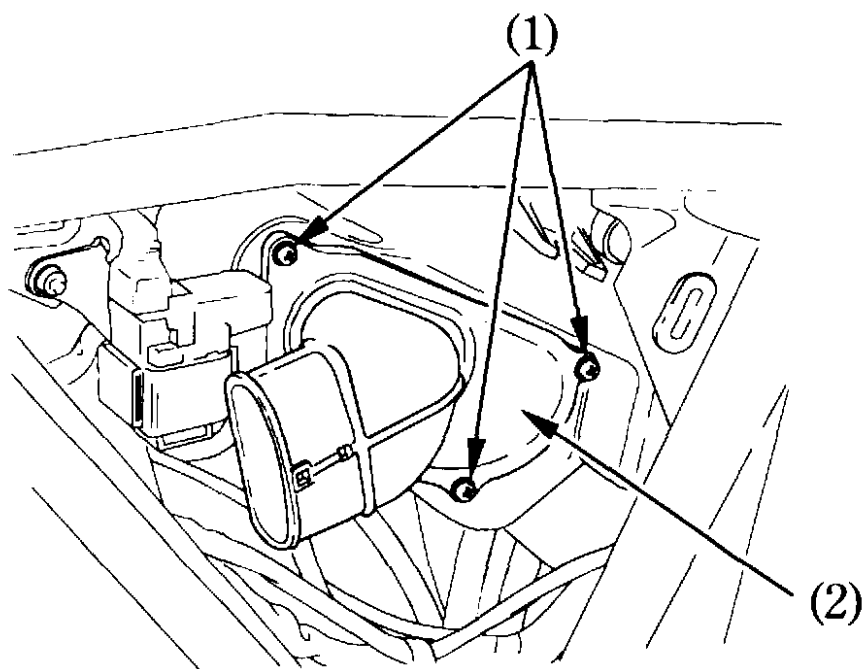

- (1) Attaching screws  
(2) Air cleaner housing cover

3. Pull the set spring (3) out.
4. Remove and discard the air cleaner (4).
5. Install a new air cleaner.

Use the Honda genuine air cleaner or an equivalent air cleaner specified for your model. Using the wrong Honda air cleaner or a non-Honda air cleaner which is not of equivalent quality may cause premature engine wear or performance problems.

6. Install the removed parts in reverse order of removal.

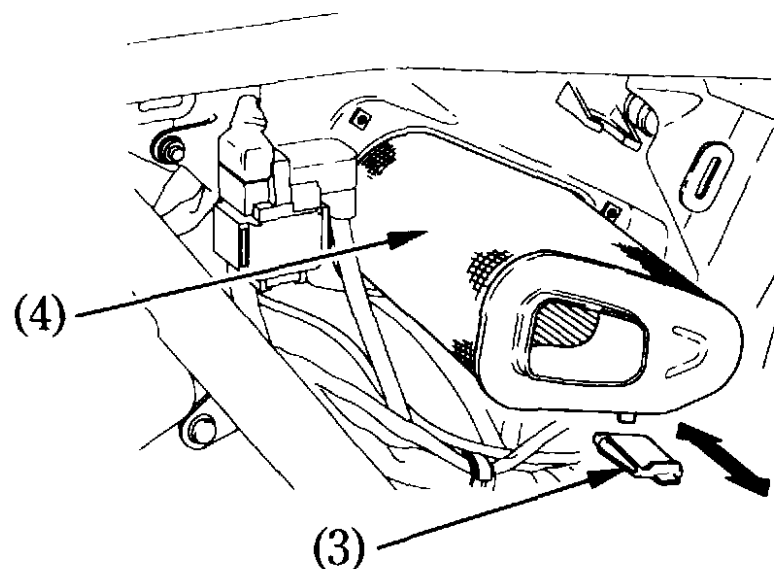

- (3) Set spring                      (4) Air cleaner

## DRIVE CHAIN

(Refer to the maintenance precautions on page 55).

The service life of the drive chain is dependent upon proper lubrication and adjustment. Poor maintenance can cause premature wear or damage to the drive chain and sprockets.

The drive chain should be checked and lubricated as part of the Pre-ride Inspection (page 39). Under severe usage, or when the motorcycle is ridden in unusually dusty or muddy areas, more frequent maintenance will be necessary.

### Inspection:

1. Turn the engine off, place the motorcycle on its side stand and shift the transmission into neutral.
2. Check slack in the lower drive chain run midway between the sprockets. Drive chain slack should be adjusted to allow the following vertical movement by hand:

25 – 35 mm (1.0 – 1.4 in)

3. Rotate the rear wheel. Stop. Check the drive chain slack. Repeat this procedure several times. Drive chain slack should remain constant. If the chain is slack only in certain sections, some links are kinked and binding. Binding and kinking can frequently be eliminated by lubrication.

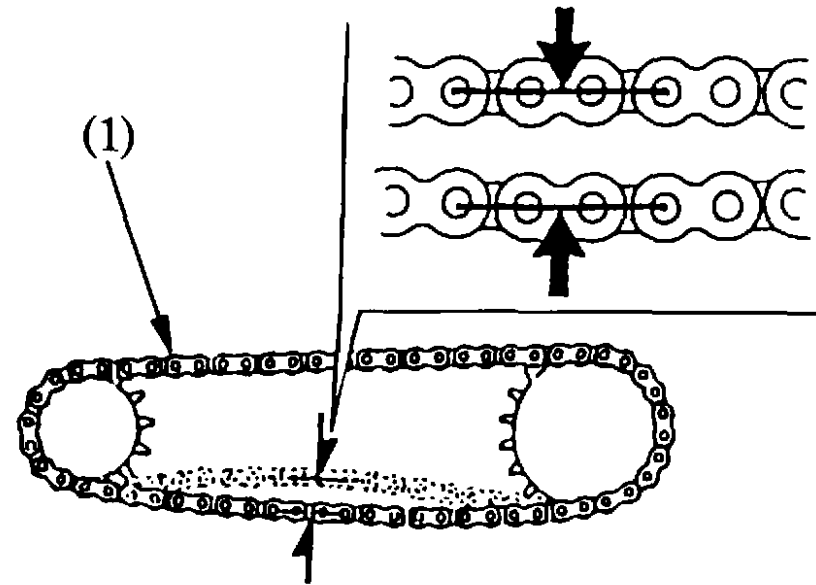

(1) Drive chain



4. Rotate the rear wheel slowly and inspect the drive chain and sprockets for any of the following conditions:

#### DRIVE CHAIN

- \*Damaged Rollers
- \*Loose Pins
- \*Dry or Rusted Links
- \*Kinked or Binding Links
- \*Excessive Wear
- \*Improper Adjustment
- \*Missing O-rings

#### SPROCKETS

- \*Excessively Worn Teeth
- \*Broken or Damaged Teeth

A drive chain with damaged rollers, loose pins, or missing O-rings must be replaced. A chain which appears dry, or shows signs of rust, requires supplementary lubrication. Kinked or binding links should be thoroughly lubricated and worked free. If links cannot be freed, the chain must be replaced.

Damaged Sprocket  
Teeth

**REPLACE**

Worn Sprocket  
Teeth

**REPLACE**

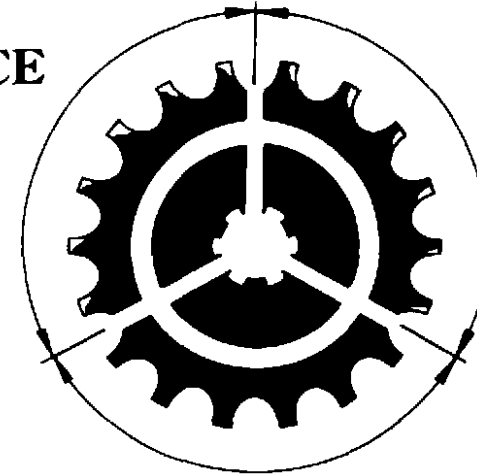

Normal Sprocket

**GOOD**

### Adjustment:

Drive chain slack should be checked and adjusted, if necessary, every 1,000 km (600 miles). When operated at sustained high speeds or under conditions of frequent rapid acceleration, the chain may require more frequent adjustment.

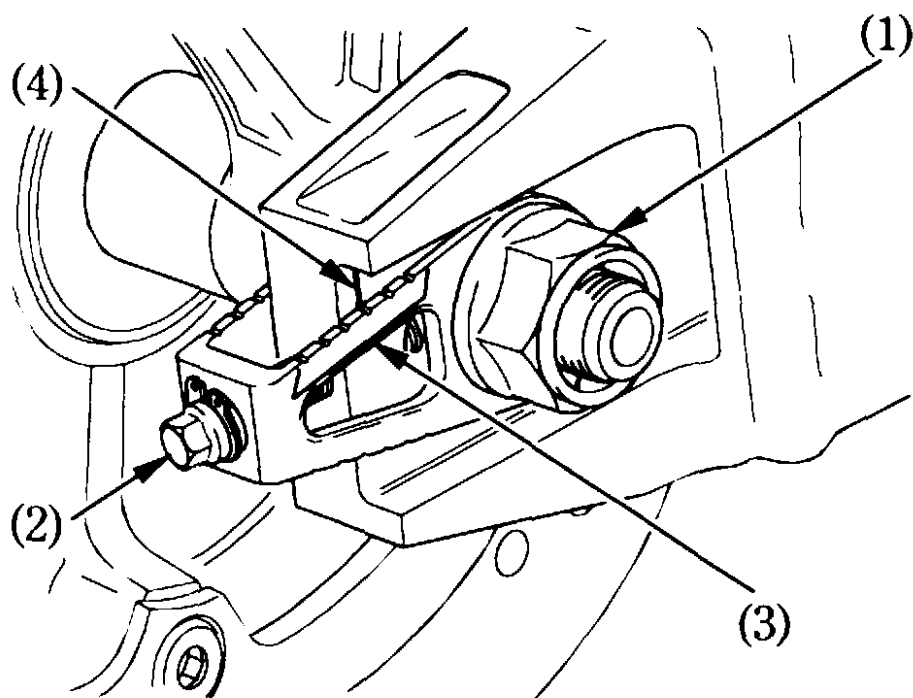

- |                    |                 |
|--------------------|-----------------|
| (1) Axle nut       | (3) Index marks |
| (2) Adjusting bolt | (4) Index mark  |

If the drive chain requires adjustment, the procedure is as follows:

1. Place the motorcycle on its center stand with the transmission in neutral and the ignition switch off.
2. Loosen the axle nut (1).
3. Turn both adjusting bolts (2) an equal number of turns until the correct drive chain slack is obtained. Turn the adjusting bolts counterclockwise to tighten the chain, or clockwise to provide more slack. Adjust the chain slack at a point midway between the drive sprocket and the rear wheel sprocket. Rotate the rear wheel and recheck slack at other sections of the chain.

Chain slack should be:

25 – 35 mm (1.0 – 1.4 in)

4. Check rear axle alignment by making sure the chain adjuster index marks (3) align with the index mark (4) on the swingarm.

Both left and right marks should correspond. If the axle is misaligned, turn the left or right adjusting nut until the marks correspond on the rear edge of the adjusting slots and recheck chain slack.

5. Tighten the axle nut to specified torque.

Axle nut torque:

93 N·m (9.3 kg-m , 67 lb-ft)

6. Tighten the adjusting bolts lightly.

#### Wear inspection:

Check the chain wear label when adjusting the chain. If the red zone (5) on the label aligns with the index mark (6) on the swingarm after the chain has been adjusted to the proper slack, the chain is excessively worn and must be replaced. The proper slack is:

25 – 35 mm (1.0 – 1.4 in)

#### **CAUTION:**

**\* Damage to the bottom part of the frame may be caused by excessive drive chain slack of more than:**

**50 mm (2.0 in)**

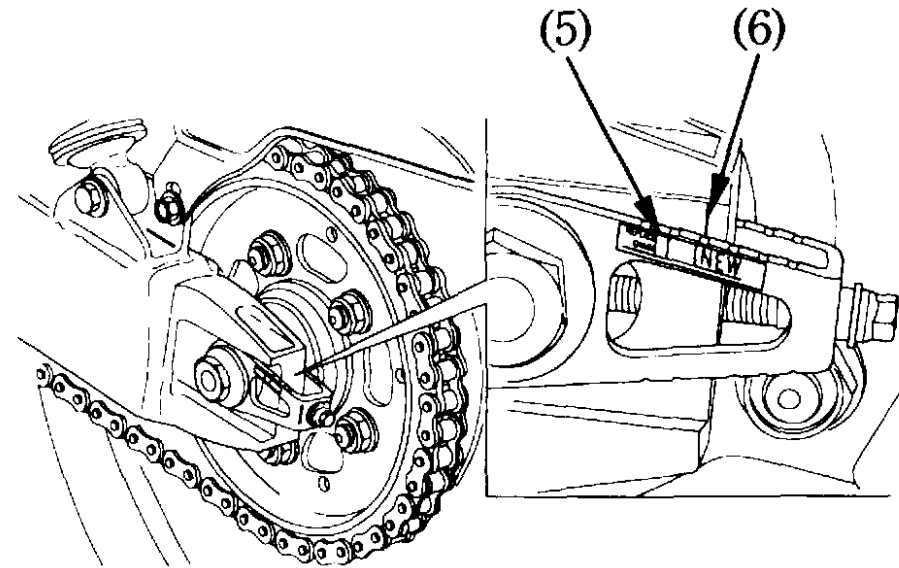

(5) Red zone

(6) Index mark

### Lubrication and cleaning:

Lubricate every 1,000 km (600 miles) or sooner if chain appears dry.

The O-rings in this chain can be damaged by steam cleaning, high pressure washers, and certain solvents. Clean the chain with high flash-point solvent, such as paraffin. Wipe dry and lubricate only with SAE 80 or 90 gear oil. Commercial chain lubricants may contain solvents which could damage the rubber O-rings.

RK50HFOZ3 or D.I.D 50VA7

### **CAUTION:**

- \* **The drive chain on this motorcycle is equipped with small O-rings between the link plates. These O-rings retain grease inside the chain to improve its service life. However, special precautions must be taken when adjusting, lubricating, washing, and replacing the chain.**

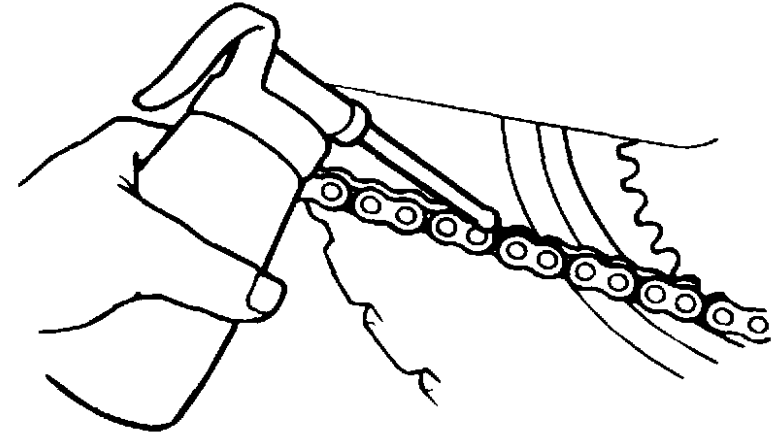

## DRIVE CHAIN SLIDER

(Refer to the maintenance precautions on page 55).

Check the chain slider (1) for wear.

The chain slider must be replaced if it is worn to the wear limit line (2). For replacement, see your authorized Honda dealer.

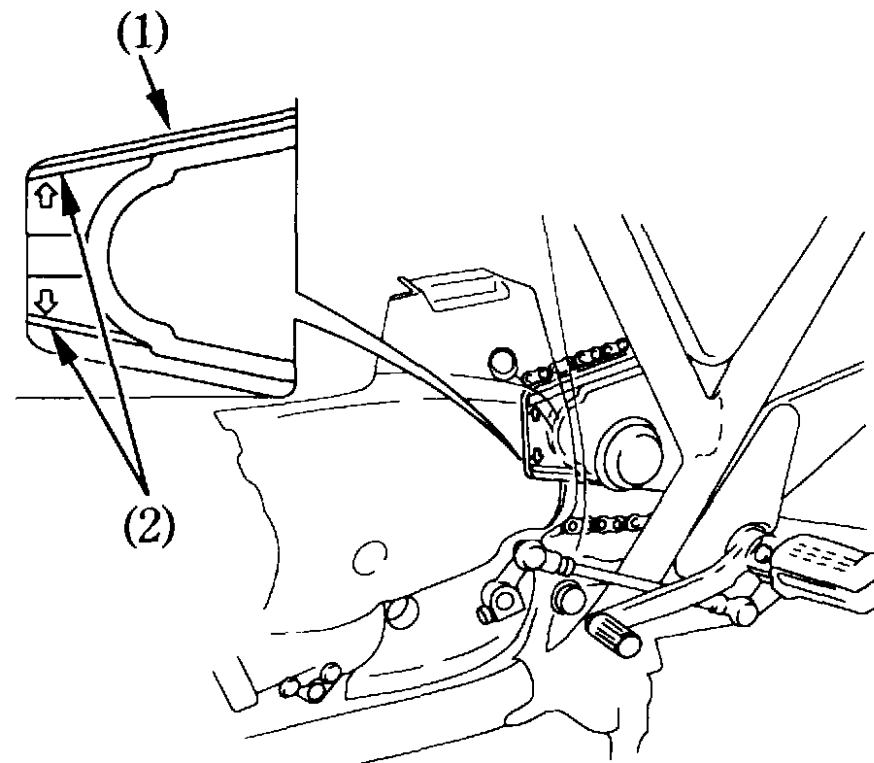

- (1) Chain slider
- (2) Wear limit line

## SIDE STAND

(Refer to the maintenance precautions on page 55).

Perform the following maintenance in accordance with the maintenance schedule.

### Functional Check:

- Check the spring (1) for damage or loss of tension and the side stand assembly for freedom of movement.
- Check the side stand ignition cut-off system:
  1. Sit astride the motorcycle; put the side stand up and the transmission in neutral.
  2. Start the engine and with the clutch lever pulled in, shift the transmission into gear.
  3. Lower the side stand. The engine should stop as you put the side stand down.

If the side stand system does not operate as described, see your authorized Honda dealer for service.

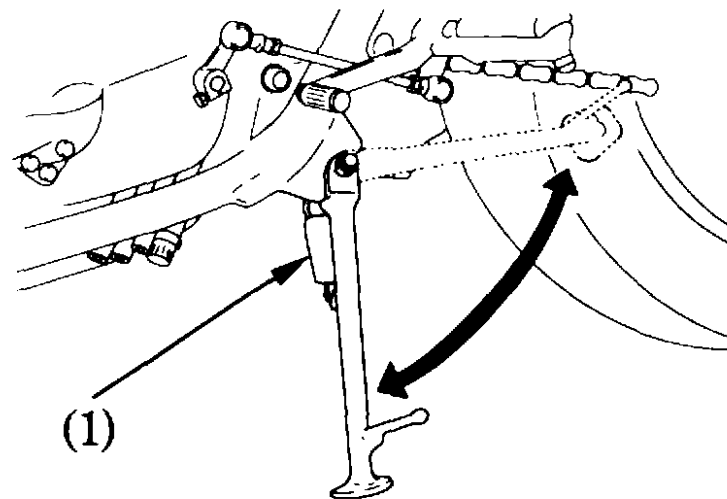

(1) Side stand spring

## WHEEL REMOVAL

(Refer to the maintenance precautions on page 55 ).

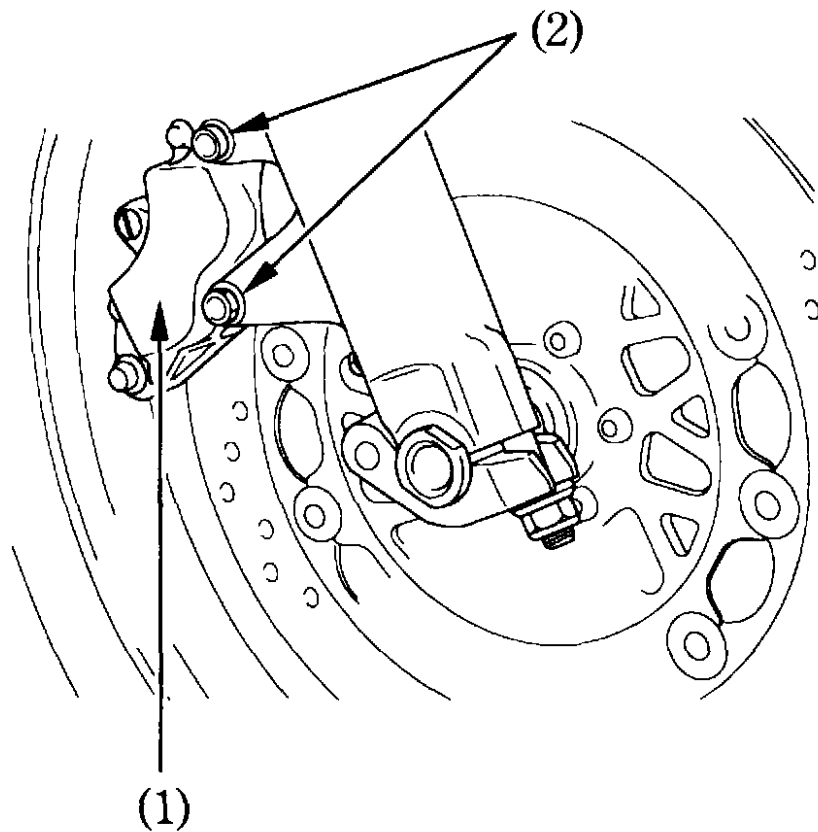

- (1) Front brake caliper
- (2) Fixing bolts

## Front Wheel Removal

1. Raise the front wheel off the ground by placing a support block under the engine.
2. Remove the both side front calipers (1) from the fork leg by removing the fixing bolts (2).

### CAUTION:

- \* To avoid damage to the brake hose, support the caliper assembly so that it doesn't hang from the hose. Do not twist the brake hose.

3. Remove the axle holder nuts (3) and washers (4) from both sides then remove the front wheel.

**NOTE:**

- \* Do not depress the brake lever when the wheel is off the motorcycle. The caliper piston will be forced out of the cylinder with subsequent loss of brake fluid. If this occurs, servicing of the brake system will be necessary. See your authorized Honda dealer for this service.

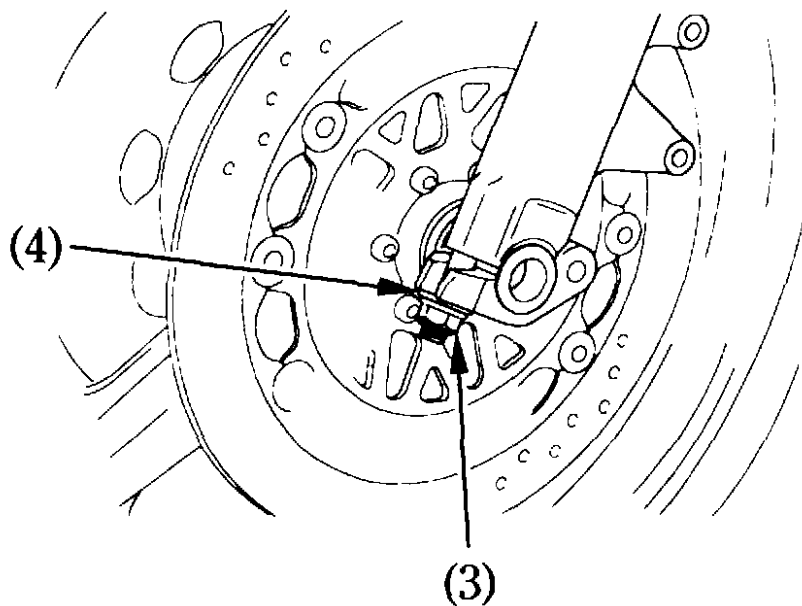

- (3) Axle holder nut
- (4) Washer

**Installation Notes:**

Set the axle in the axle holders.

Install the washer and axle holder nuts to specified torque.

Axle holder nut torque:

59 N·m (5.9 kg-m , 43 lb-ft)

Fit the caliper over the disc, taking care not to damage the brake pads. Install the caliper fixing bolts, and tighten to a torque of :

31 N·m (3.1 kg-m , 22 lb-ft)

**CAUTION:**

- \* When installing the wheel, carefully fit the brake disc between the brake pads to avoid damaging the pads.



Measure the clearance (5) between each surface of the brake disc (6) and the caliper holder (7) with a 0,7 mm (0,028 in) feeler gauge (8) (see illustration).

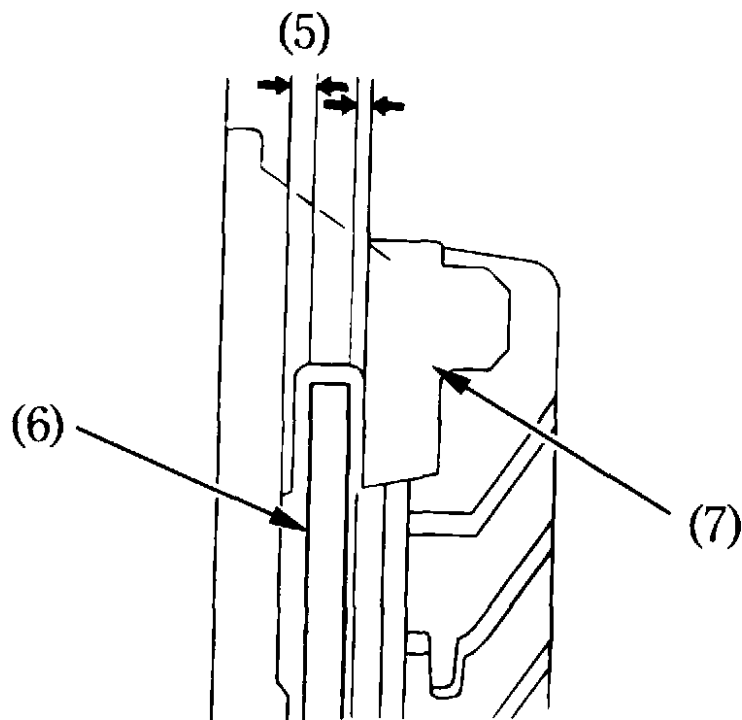

(5) Clearance  
(6) Brake disc

(7) Caliper holder

### **⚠ WARNING**

**\* If a torque wrench was not used for installation, see your authorized Honda dealer as soon as possible to verify proper assembly. Improper assembly may lead to loss of braking capacity.**

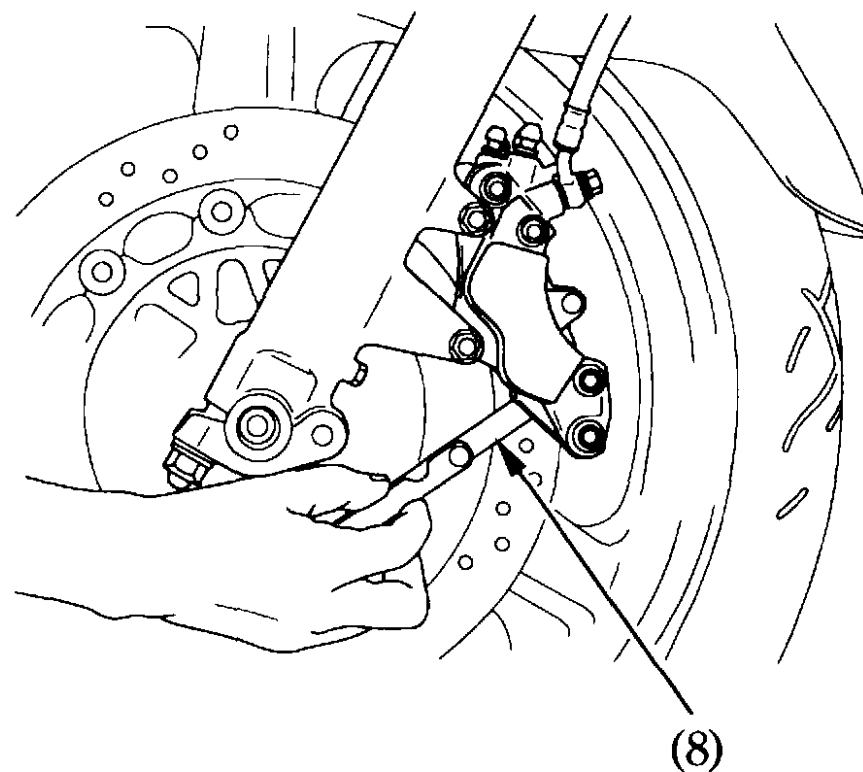

(8) Feeler gauge

If the feeler gauge cannot be inserted easily, pull the fork outward or push inward until the gauge can be inserted and tighten the axle pinch bolts with the gauge inserted. After tightening, remove the gauge. After installing the wheel, apply the brakes several times, then recheck both discs for caliper holder to disc clearance. Do not operate the motorcycle without adequate clearance.

**▲WARNING**

- \* **Failure to provide adequate disc to caliper holder clearance may damage the brake discs and impair braking efficiency.**

## Rear Wheel Removal

1. Place the motorcycle on its center stand.
2. Loosen the rear axle nut.
3. Loosen the drive chain adjusting bolts (1).
4. Remove the rear axle nut.
5. Remove the drive chain (2) from the driven sprocket by pushing the rear wheel forward.

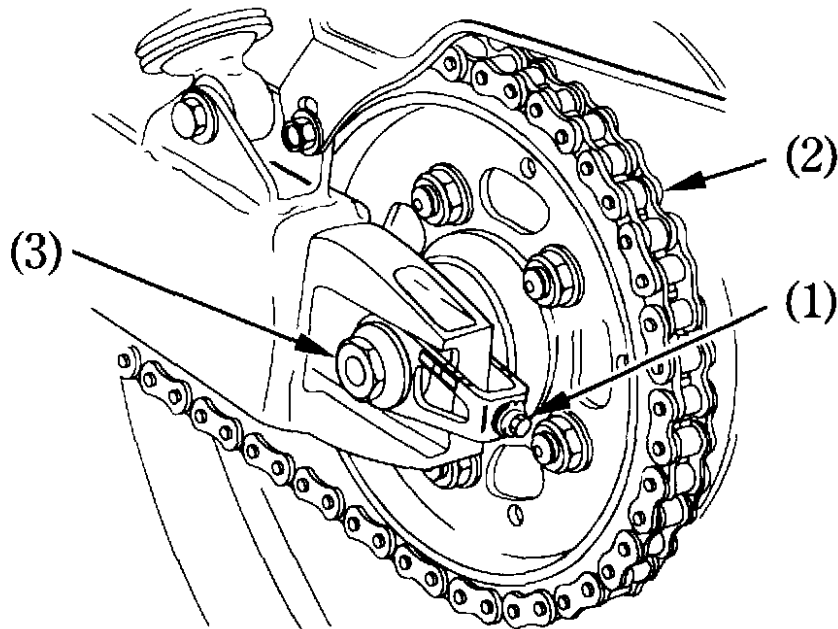

- (1) Adjusting bolt  
(2) Drive chain

- (3) Axle shaft

6. Remove the axle shaft (3), side collar and rear wheel from the swing arm.

### NOTE:

- \* Do not depress the brake pedal while the wheel is off the motorcycle. The caliper pistons will be forced out of the cylinders with subsequent loss of brake fluid. If this occurs, servicing of the brake system will be necessary. See your authorized Honda dealer for this service.

Installation:

To install the rear wheel, reverse the removal procedure. Torque the axle nut to the specified torque.

Axle nut torque:

93 N·m (9.3 kg-m , 67 lb-ft)

**CAUTION:**

- **When installing the wheel, carefully fit the brake disc between the brake pads to avoid damaging the pads.**

After installing the wheel, apply the brake several times and then check if the wheel rotates freely. Recheck the wheel if the brake drags or if the wheel does not rotate freely.

**⚠ WARNING**

- **If a torque wrench was not used for installation, see your authorized Honda dealer as soon as possible to verify proper assembly. Improper assembly may lead to loss of braking capacity.**

## BRAKE PAD WEAR

(Refer to the maintenance precautions on page 55).

Brake pad wear depends upon the severity of usage, the type of riding, and road conditions. (Generally, the pads will wear faster on wet and dirty roads.)

Inspect the pads at each regular maintenance interval (page 51).

### Front Brake

Remove the cover (1) from the caliper. Check the grooves (2) in each pad.

If either pad is worn to the bottom of the grooves, replace both pads as a set. See your authorized Honda dealer for this service.

### < FRONT BRAKE >

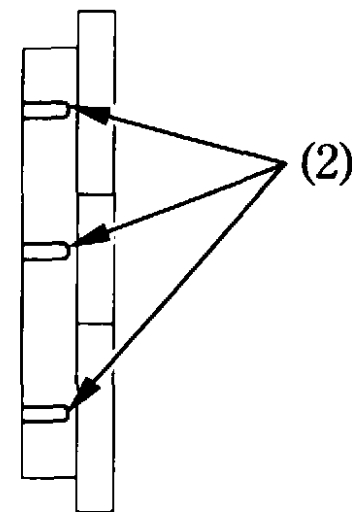
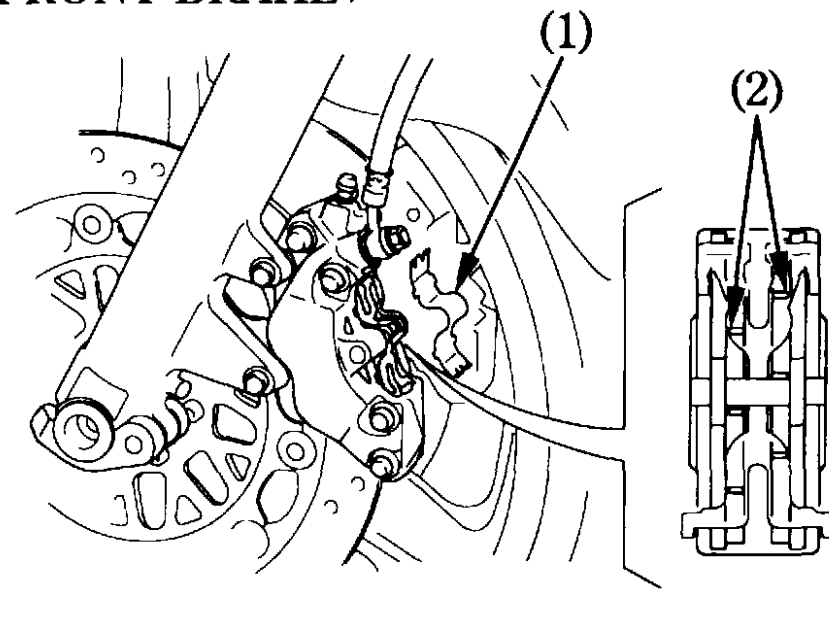

(1) Cover

(2) Grooves

## Rear Brake

Check the cutout (3) in each pad.  
If either pad is worn to the cutout, replace both pads as a set. See your authorized Honda dealer for this service.

### < REAR BRAKE >

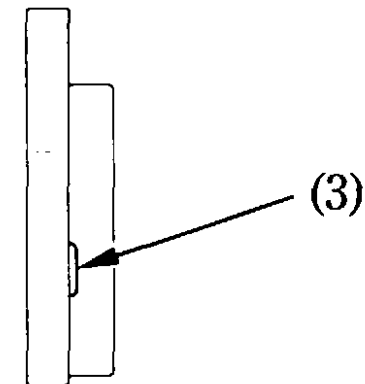
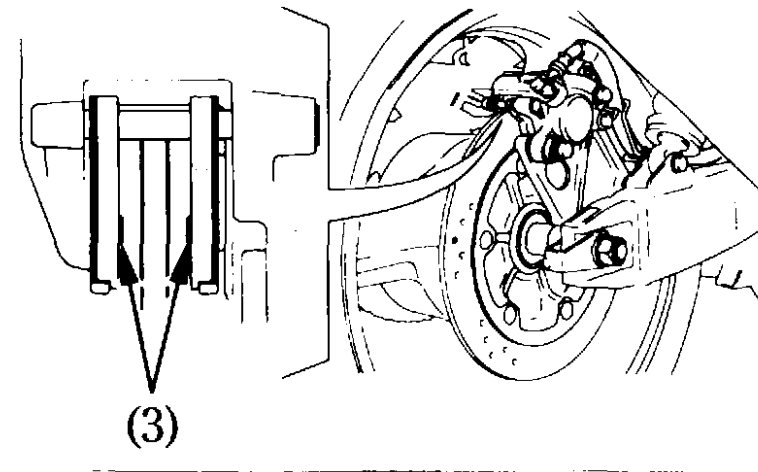

(3) Cutout

## **BATTERY**

(Refer to the maintenance precautions on page 55).

It is not necessary to check the battery electrolyte level or add distilled water as the battery is a maintenance-free (sealed) type. If your battery seems weak and/or is leaking electrolyte (causing hard starting or other electrical troubles), contact your authorized Honda dealer.

### **▲WARNING**

- \* **The battery gives off explosive gases; keep sparks, flames, and cigarettes away. Provide adequate ventilation when charging or using the battery in an enclosed space.**

### **▲WARNING**

- \* **The battery contains sulfuric acid (electrolyte). Contact with skin or eyes may cause severe burns. Wear protective clothing and a face shield.**
  - **If electrolyte gets on your skin, flush with water.**
  - **If electrolyte gets in your eyes, flush with water for at least 15 minutes and call a physician immediately.**
- \* **Electrolyte is poisonous.**
  - **If swallowed, drink large quantities of water or milk and follow with milk of magnesia or vegetable oil and call a physician.**
- \* **KEEP OUT OF REACH OF CHILDREN.**

## CAUTION:

- \* Removing the battery caps can damage the caps and result in leaks and eventual battery damage.
- \* When the motorcycle is to be stored for an extended period of time, remove the battery from the motorcycle and charge it fully. Then store it in a cool, dry place. If the battery is to be left in the motorcycle, disconnect the negative cable from the battery terminal.

## Battery Removal

1. Remove the seat (page 36).
2. Disconnect the negative (-) terminal lead (1) from the battery.
3. Remove the battery cover (2).
4. Disconnect the positive (+) terminal lead (3) from the battery.
5. Pull out the battery (4) from the battery box.

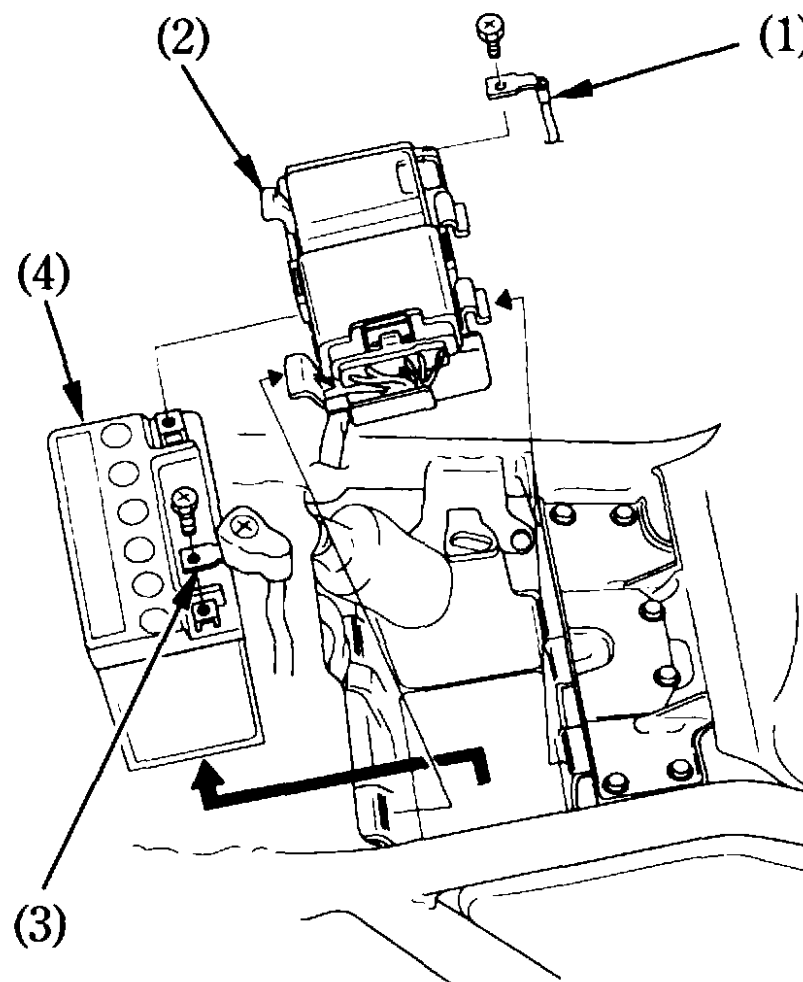

- (1) Negative (-) terminal lead
- (2) Battery cover
- (3) Positive (+) terminal lead
- (4) Battery



## FUSE REPLACEMENT

(Refer to the maintenance precautions on page 55).

When frequent fuse failure occurs, it usually indicates a short circuit or an overload in the electrical system. See your authorized Honda dealer for repair.

### CAUTION:

Turn the ignition switch OFF before checking or replacing fuses to prevent accidental short-circuiting.

### ▲WARNING

- \* Never use a fuse with a different rating from that specified. Serious damage to the electrical system or a fire may result, causing a dangerous loss of lights or engine power.

Blown fuse

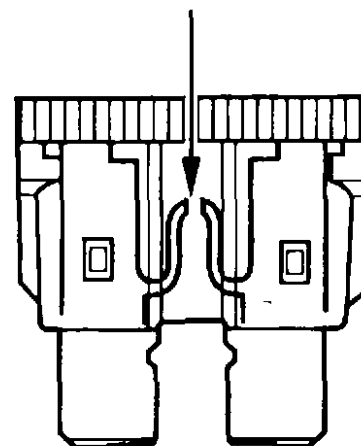

### Main fuse:

The main fuse is located behind the right side cover. The specified fuse is:

**30A**

Remove the right side cover (page 37).

Disconnect the wire coupler (1) of the stater magnetic switch.

Pull out the old fuse (2) and install a new fuse.

The spare fuse (3) is located under the starter magnetic switch.

Reconnect the wire coupler and install the right side cover.

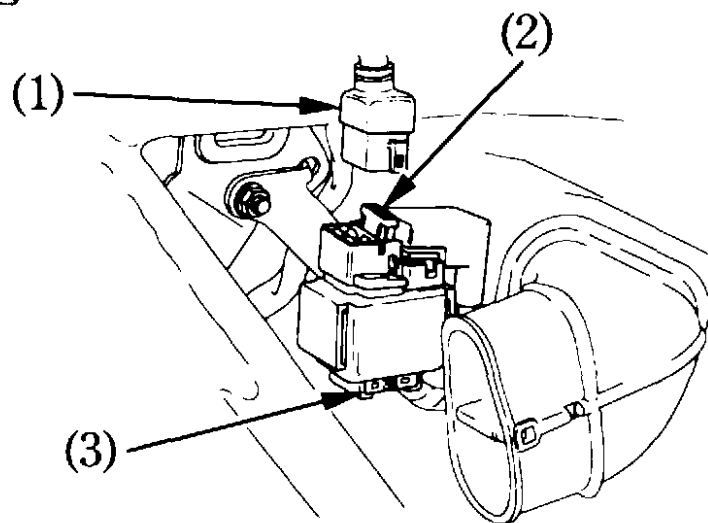

(1) Wire coupler

(3) Spare main fuse

(2) Main fuse

### Fuse box:

The fuse box is located under the seat. The specified fuse are:

**10A and 15A**

Remove the seat (page 36).

Remove the fuse box cover (4).

Pull out the old fuse and install a new fuse.

The spare fuses (5) are located in the fuse box.

Install the fuse box cover.

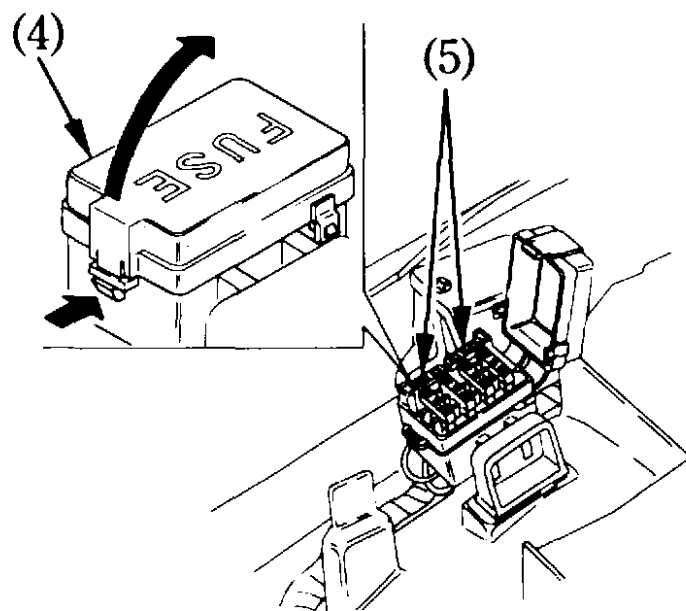

(4) Fuse box cover

(5) Spare fuses

## **BULB REPLACEMENT**

(Refer to the maintenance precautions on page 55).

### **⚠ WARNING**

- \* **The light bulb becomes very hot while the light is ON, and remain hot for a while after it is turned OFF. Be sure to let it cool down before servicing.**

### **CAUTION:**

- \* **Do not put finger prints on the headlight bulb, as they may create hot spots on the bulb and cause it to break.**

**Wear clean gloves while replacing the bulb.**

**If you touch the bulb with your bare hands, clean it with a cloth moistened with alcohol to prevent its early failure.**

### **NOTE:**

- \* **Be sure to turn the ignition switch OFF when replacing the bulb.**
- \* **Do not use bulbs other than that specified.**
- \* **After installing a new bulb, check that the light operates properly.**

## Headlight/Position Light Bulb

1. Remove the screws (1) from the headlight case.
2. Gently pull the headlight forward and disconnect the connectors (2).

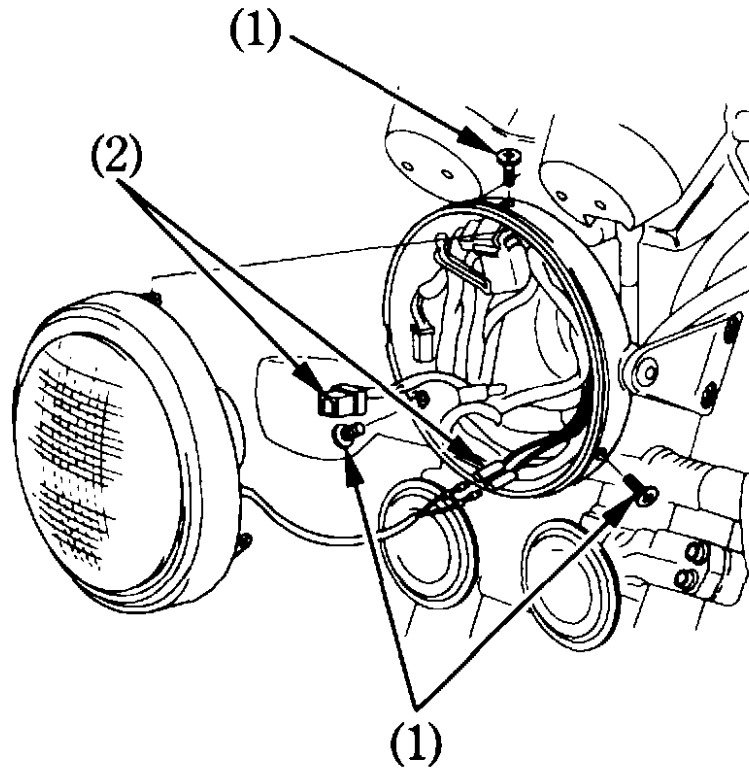

- (1) Screws  
(2) Connectors

3. Remove the seat rubber (3).
4. Remove the bulb (4) while pressing down on the pin (5).
5. Install a new bulb in the reverse order of removal.

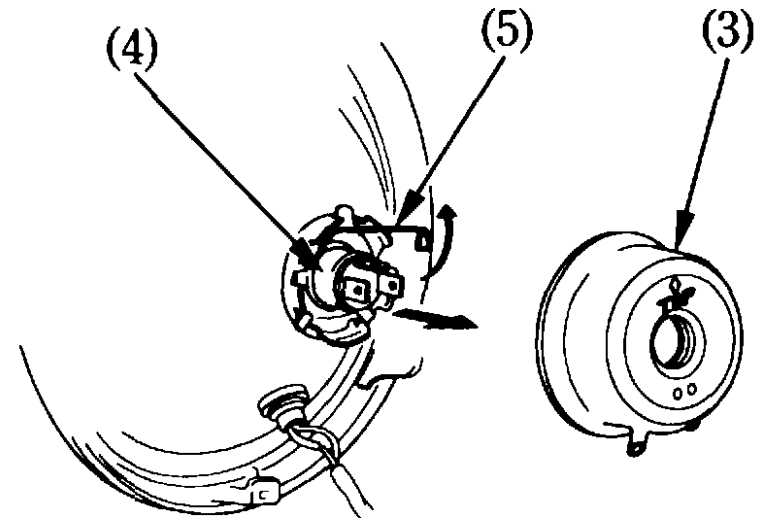

- (3) Seat rubber  
(4) Bulb  
(5) Pin

## Stop/Taillight Bulb

1. Remove the four screws (1).
2. Remove the taillight lens (2).

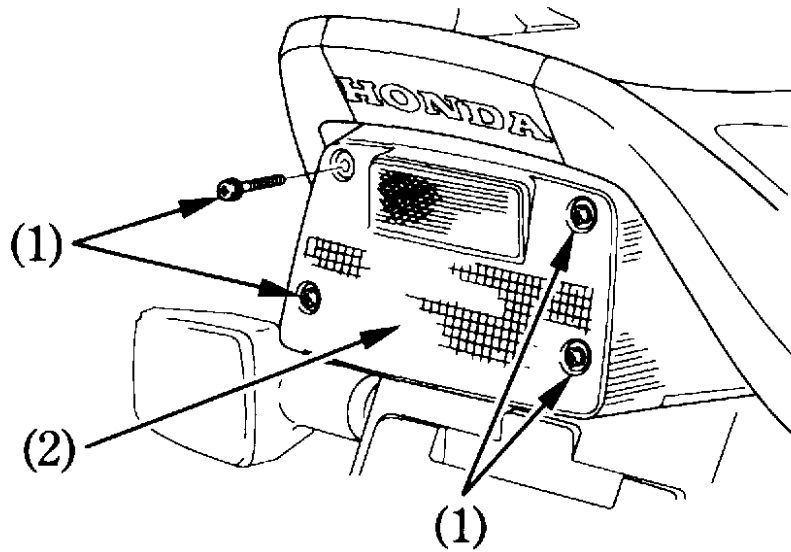

- (1) Screws  
(2) Taillight lens

3. Slightly press down on the bulb (3) and turn it counterclockwise.
4. Install a new bulb in the reverse order of removal.

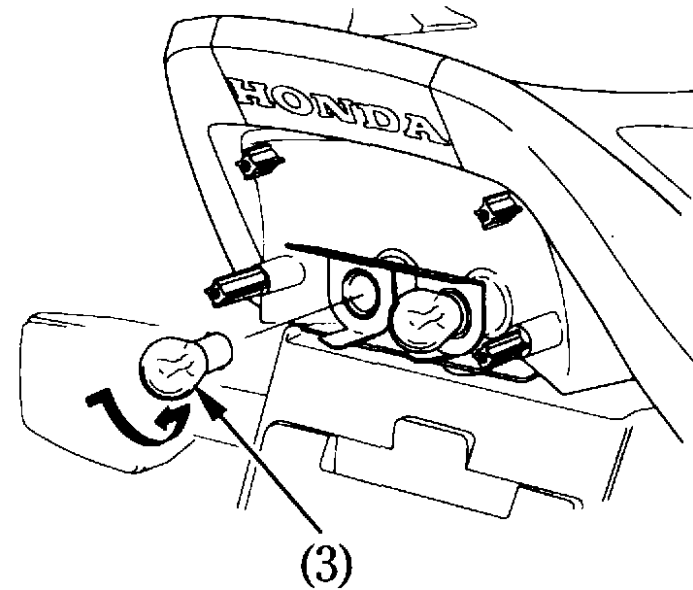

- (3) Bulb

## Front/Rear Turn Signal Bulb

1. Remove the three screws (1).
2. Remove the turn signal lens (2).

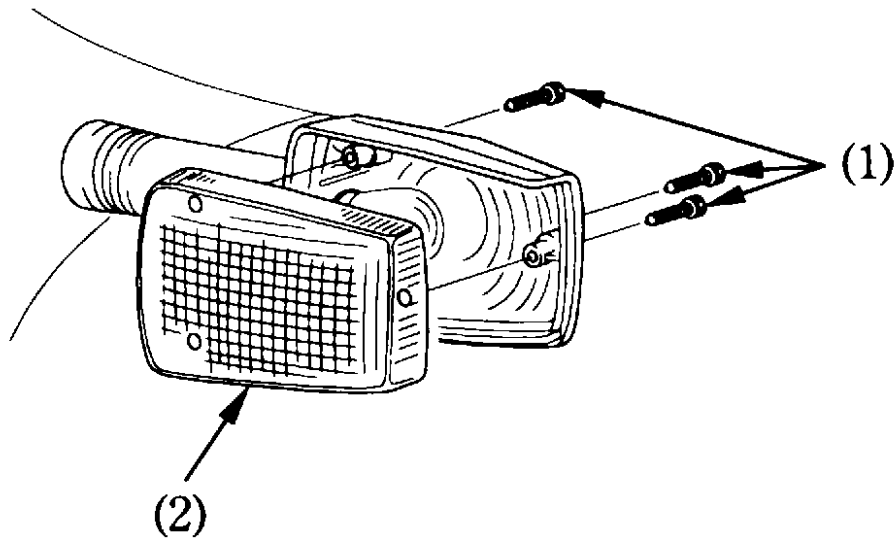

- (1) Screws  
(2) Turn signal lens

3. Remove the bulb (3) by pressing in and turning counterclockwise.
4. Install a new bulb and check that the light operates properly.

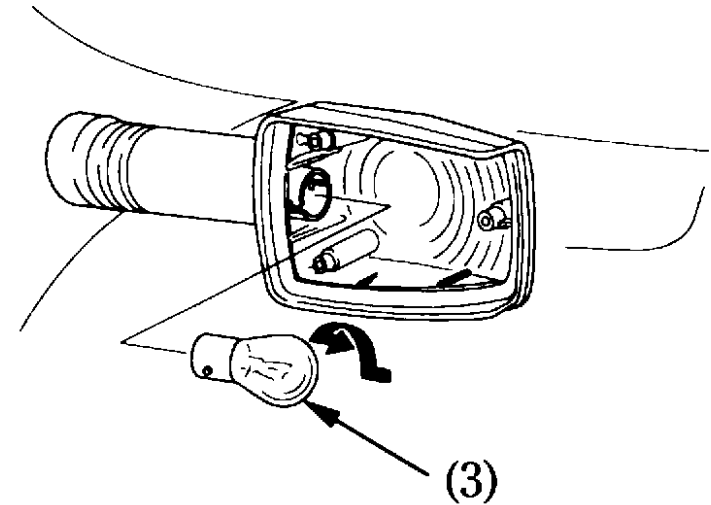

- (3) Bulb

## STOPLIGHT SWITCH ADJUSTMENT

(Refer to the maintenance precautions on page 55).

Check the operation of the stoplight switch (1) at the right side behind the engine from time to time.

Adjustment is done by turning the adjusting nut (2). Turn the nut in the direction (A) if the switch operates too late and in direction (B) if the switch operates too soon.

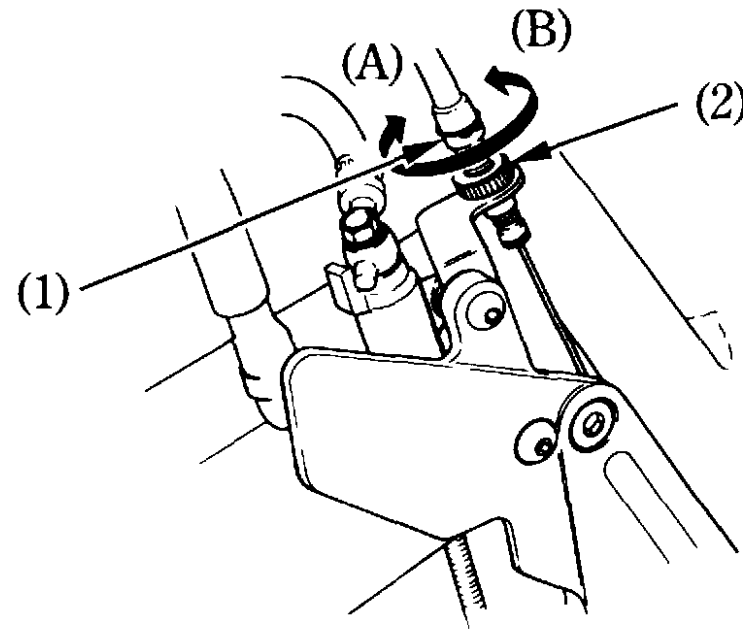

- (1) Stoplight switch
- (2) Adjusting nut

## CLEANING

Clean your motorcycle regularly to protect the surface finishes and inspect for damage, wear and oil, coolant or fluid (brake and clutch) leakage.

### CAUTION:

- \* **High pressure water (or air) can damage certain parts of the motorcycle.**

Avoid spraying high pressure water (typical in coin-operated car washes) at the following areas:

Ignition Switch	Instruments
Carburetors	Wheel Hubs
Drive Chain	Muffler Outlets
Under Seat	Under Fuel Tank
Handlebar Switches	
Brake Master Cylinder	
Clutch Master Cylinder	

1. After cleaning, rinse the motorcycle thoroughly with plenty of clean water. Strong detergent residue can corrode alloy parts.

### NOTE:

- \* Clean the plastic parts using a cloth or sponge dampened with a solution of mild detergent and water. Rub the soiled area gently rinsing it frequently with fresh water.
2. Dry the motorcycle, start the engine, and let it run for several minutes.
  3. Test the brakes before riding the motorcycle. Several applications may be necessary to restore normal braking performance.

### **▲WARNING**

- \* **Braking efficiency may be temporarily impaired immediately after washing the motorcycle. Anticipate longer stopping distance to avoid a possible accident.**
4. Lubricate the drive chain immediately after washing and drying the motorcycle.



## **Aluminum Wheel Maintenance**

Aluminum corrodes when it comes in contact with dust, mud, road salt, etc. After riding, clean the wheels with a wet sponge and mild detergent, then rinse well with water and wipe dry with a clean cloth.

### **CAUTION:**

- \* Do not use steel wool or a cleaner containing abrasives or compounds to clean the wheels, as they can cause damage.**
- \* Do not ride over a curb or rub the wheel against an obstacle, as wheel damage may result.**

## STORAGE GUIDE

Extended storage, such as for winter, requires that you take certain steps to reduce the effects of deterioration from non-use of the motorcycle. In addition, necessary repairs should be made **BEFORE** storing the motorcycle; otherwise, these repairs may be forgotten by the time the motorcycle is removed from storage.

### STORAGE

1. Change the engine oil and filter.
2. Make sure the cooling system is filled with a 50/50% antifreeze solution.
3. Empty the fuel tank into an approved petrol container using a commercially available hand siphon or an equivalent method. Spray the inside of the tank with an aerosol rust-inhibiting oil.  
Reinstall the fuel fill cap on the tank.

### NOTE:

- \* If storage will last more than one month, carburetor draining is very important, to assure proper performance after storage.

### **▲WARNING**

- \* **Petrol is extremely flammable and is explosive under certain conditions. Perform this operation in a well-ventilated area with the engine stopped. Do not smoke or allow flames or sparks in the area where petrol is drained or stored and where the fuel tank is refueled.**

4. To prevent rusting in the cylinders, perform the following:

- Remove the spark plug caps from the spark plugs. Using tape or string, secure the caps to any convenient plastic body part so that they are positioned away from the spark plugs.
- Remove the spark plugs from the engine and store them in a safe place. Do not connect the spark plugs to the spark plug caps.
- Pour a tablespoon (15–20 cc) of clean engine oil into each cylinder and cover the spark plug holes with a piece of cloth.
- Crank the engine several times to distribute the oil.
- Reinstall the spark plugs and spark plug caps.

5. Remove the battery. Store in an area protected from freezing temperatures and direct sunlight.

Slow charge the battery once a month.

6. Wash and dry the motorcycle. Wax all painted surfaces. Coat chrome with rustinhibiting oil.

7. Lubricate the drive chain (page 70).

8. Inflate the tyres to their recommended pressures. Place the motorcycle on blocks to raise both tyres off the ground.

9. Cover the motorcycle (don't use plastic or other coated materials) and store in an unheated area, free of dampness with a minimum of daily temperature variation. Do not store the motorcycle in direct sunlight.

## **REMOVAL FROM STORAGE**

1. Uncover and clean the motorcycle.  
Change the engine oil if more than 4 months have passed since the start of storage.
2. Charge the battery as required. Install the battery.
3. Drain any excess aerosol rust-inhibiting oil from the fuel tank. Fill the fuel tank with fresh petrol.
4. Perform all Pre-ride Inspection checks (page 39).  
Test ride the motorcycle at low speeds in a safe riding area away from traffic.

# SPECIFICATIONS

## DIMENSIONS

Overall length	2,220 mm (87.4 in) ...F, ED, SP, E, U 2,340 mm (92.1 in) ...G, II G, AR, SW, ND
Overall width	785 mm (30.9 in)
Overall height	1,130 mm (44.5 in)
Wheelbase	1,540 mm (60.6 in)

## WEIGHT

Dry weight	235 kg (518 lbs) ...E, G, II G, F, ED, SP, ND, U 236 kg (520 lbs) ...AR, SW
------------	--

## CAPACITIES

Engine oil	After draining	3.9 ℓ (4.1 US qt , 3.4 Imp qt)
	After draining and oil filter change	4.0 ℓ (4.2 US qt , 3.5 Imp qt)
	After disassembly	4.6 ℓ (4.9 US qt , 4.0 Imp qt)
Fuel tank		22 ℓ (5.8 US gal , 4.8 Imp gal)
Fuel reserve		4.0 ℓ (1.06 US gal , 0.88 Imp gal)
Cooling system capacity		2.8 ℓ (0.74 US gal , 0.62 Imp gal)
Passenger capacity		Operator and one passenger
Maximum weight capacity		188 kg (415 lbs)

## ENGINE

Bore and stroke	77.0 x 53.6 mm (3.03 x 2.11 in)
Compression ratio	10.0 : 1
Displacement	998 cm <sup>3</sup> (60.9 cu-in)
Spark plug	
Standard	DPR9EA-9 (NGK) or X27EPR-U9 (NIPPONDENSO)
Spark plug gap	0.8-0.9 mm (0.03-0.04 in)
Idle speed	1,000 ± 100 min <sup>-1</sup> (rpm) < Except SW, AR > 1,100 ± 100 min <sup>-1</sup> (rpm) < AR only > 1,100 ± 50 min <sup>-1</sup> (rpm) < SW only >

## **CHASSIS AND SUSPENSION**

Caster	27°
Trail	111 mm (4.4 in)
Tyre size, front	120/70R18—59V
Tyre size, rear	170/60R18—73V

## **POWER TRANSMISSION**

Primary reduction	1.785
Gear ratio, 1st	2.833
2nd	1.941
3rd	1.500
4th	1.217
5th	1.040
Final reduction	2.470

## **ELECTRICAL**

Battery

12V – 10AH

Generator

0.42 kw/5,000 min<sup>-1</sup> (rpm)

## **LIGHTS**

Headlight

12V – 60/55W

Tail / brake light

12V – 21/5W x 2

Turn signal light

Front

12V – 21W

Rear

12V – 21W

Speedometer light

12V – 3.4W

Tachometer lights

12V – 1.7W x 2

Coolant temperature gauge light

12V – 1.4W

Neutral indicator

12V – 3.4W

Turn signal indicator

12V – 3.4W

High beam indicator

12V – 1.7W

Low oil pressure indicator

12V – 3.4W

Side stand indicator

12V – 3.4W

## **FUSE**

30A

10A and 15A



## **NOISE CONTROL SYSTEM (AUSTRALIA ONLY)**

**TAMPERING WITH THE NOISE CONTROL SYSTEM IS PROHIBITED:** Owners are warned that the law may prohibit : (a) The removal or rendering inoperative by any person other than for purposes of maintenance, repair, or replacement, of any device or element of design incorporated into any new vehicle for the purpose of noise control prior to its sale or delivery to the ultimate purchaser or while it is in use; and (b) the use of the vehicle after such device or element of design has been removed or rendered inoperative by any person.





# CB1000

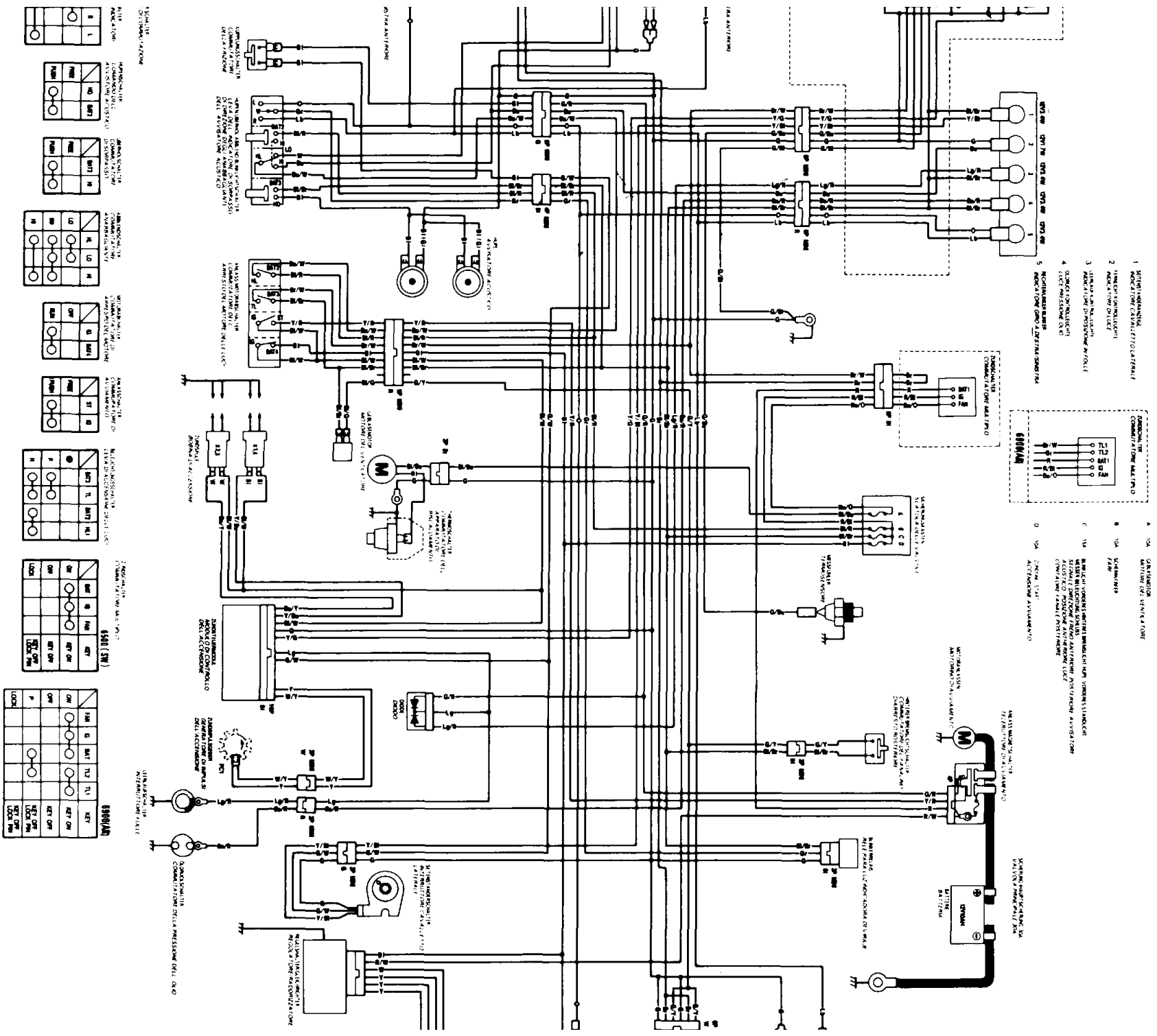

# CB1000

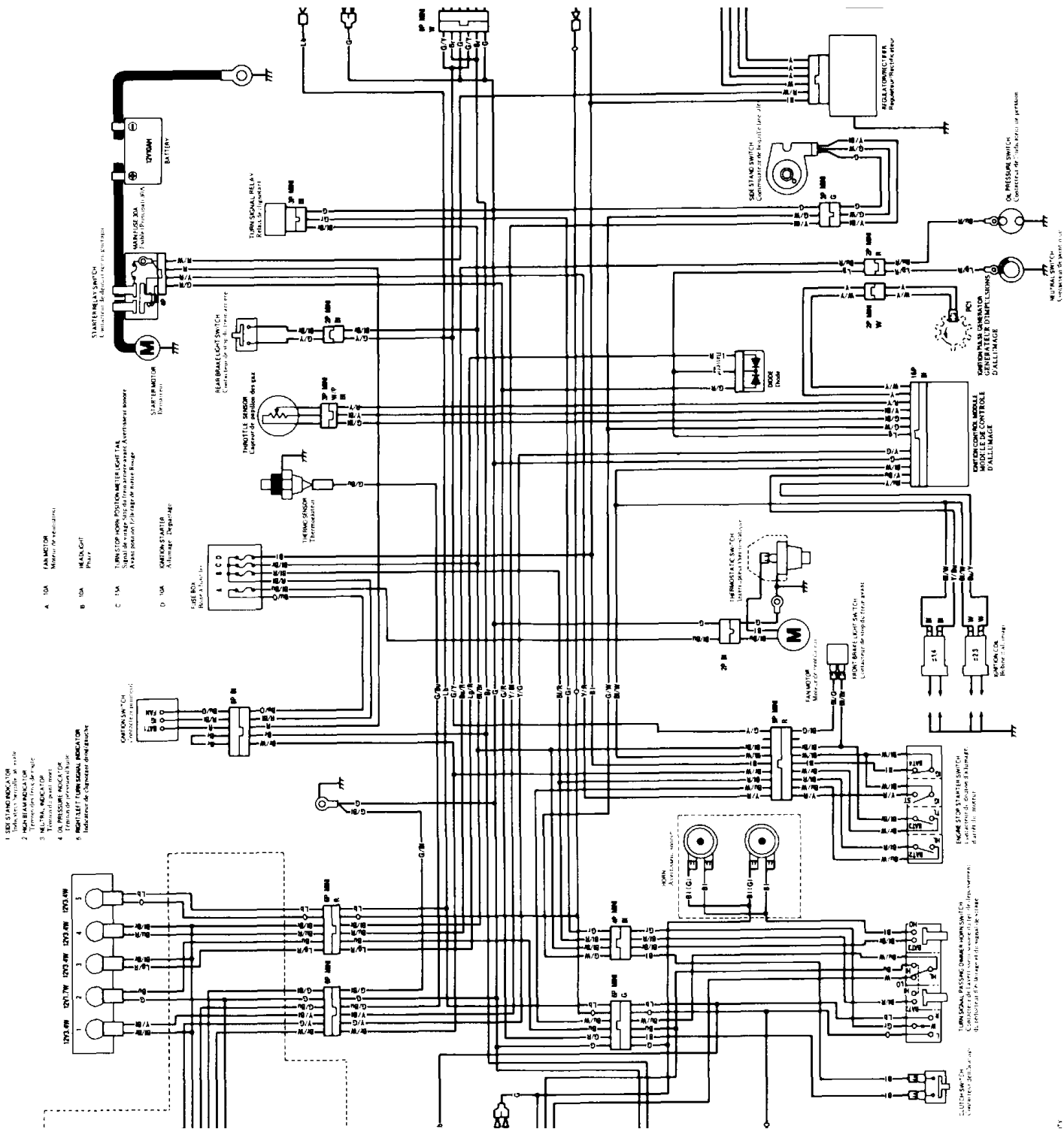

- 1. LED STANDARD LIGHT
- 2. HEAD LIGHT
- 3. HEADLIGHT POSITION
- 4. OIL PRESSURE INDICATOR
- 5. NIGHT/LEET TURN SIGNAL INDICATOR

- A. 10A FUSE
- B. 10A FUSE
- C. 15A FUSE
- D. 10A FUSE

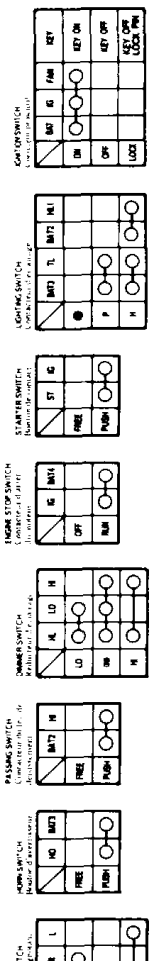



# CB1000

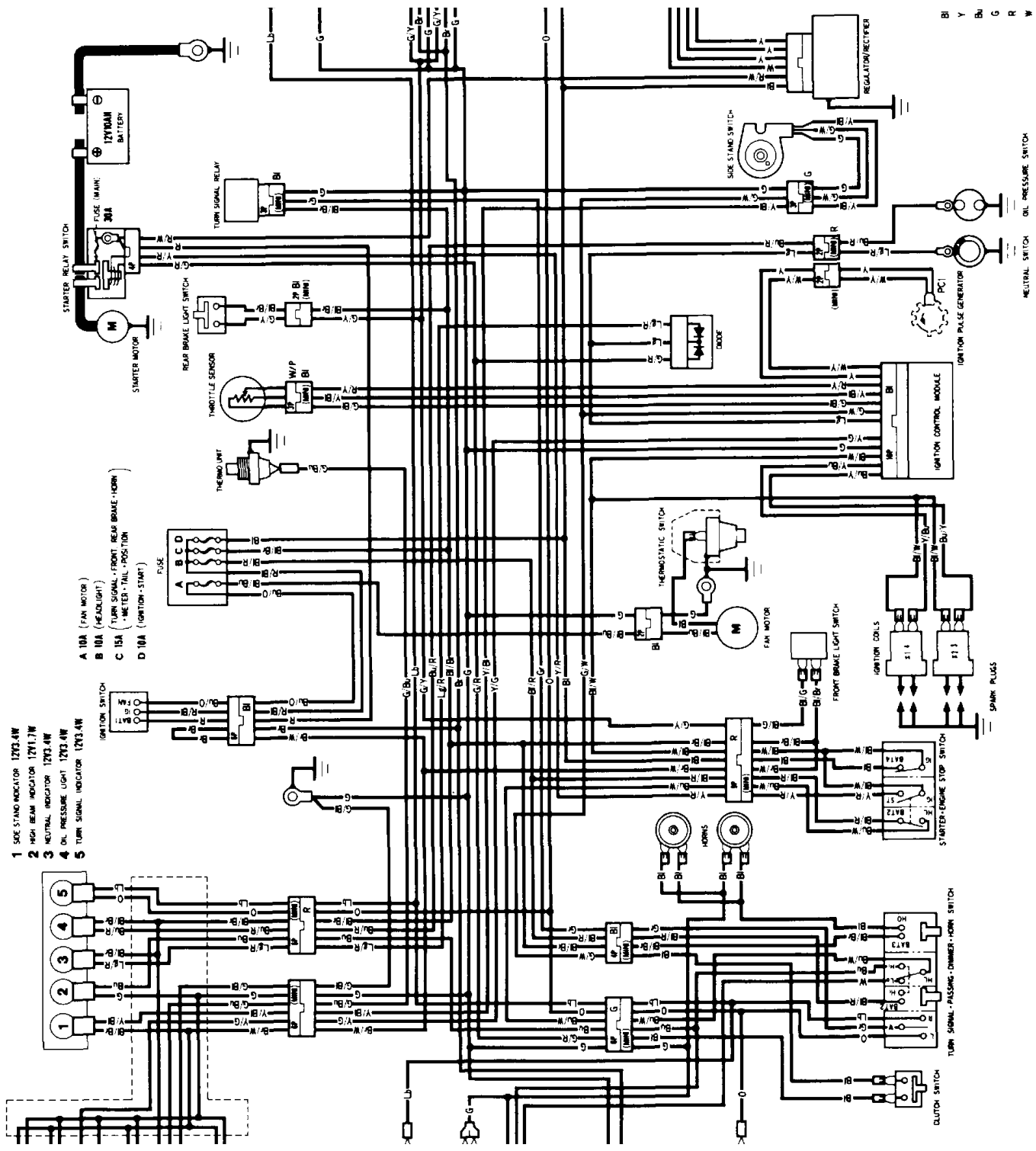

- 1 SIDE STAND INDICATOR 12V3.4W
- 2 HIGH BEAM INDICATOR 12V1.7W
- 3 NEUTRAL INDICATOR 12V3.4W
- 4 OIL PRESSURE LIGHT 12V3.4W
- 5 TURN SIGNAL INDICATOR 12V3.4W

- A 10A (FAN MOTOR)
- B 10A (HEADLIGHT)
- C 15A (TURN SIGNAL, FRONT, REAR BRAKE, HORN)
- D 10A (IGNITION-START)

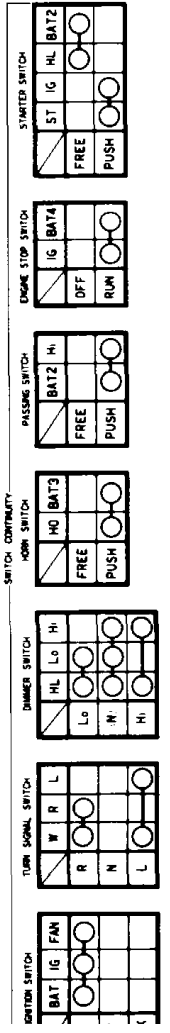

SWITCH CONNECTION

BI Y BU G R W