

This manual should be considered a permanent part of the motorcycle and should remain with the motorcycle when it is resold.

This publication includes the latest production information available before printing. Honda Motor Co., Ltd. reserves the right to make changes at any time without notice and without incurring any obligation.

No part of this publication may be reproduced without written permission.

The vehicle pictured in this owner's manual may not match your actual vehicle.

Welcome

Congratulations on your purchase of a new Honda motorcycle. Your selection of a Honda makes you part of a worldwide family of satisfied customers who appreciate Honda's reputation for building quality into every product.

To ensure your safety and riding pleasure:

- Read this owner's manual carefully.
- Follow all recommendations and procedures contained in this manual.
- Pay close attention to safety messages contained in this manual and on the motorcycle.

- The following codes in this manual indicate each country.
- The illustrations here in are based on the VFR800F II ED type.

Country Codes

Code	Country
------	---------

VFR800F	
----------------	--

II ED	European direct sales South Africa, UK, France
-------	---

II U	Australia, New Zealand
------	------------------------

*The specifications may vary with each locale.

A Few Words About Safety

Your safety, and the safety of others, is very important. Operating this motorcycle safely is an important responsibility.

To help you make informed decisions about safety, we have provided operating procedures and other information on safety labels and in this manual. This information alerts you to potential hazards that could hurt you or others.

Of course, it is not practical or possible to warn you about all hazards associated with operating or maintaining a motorcycle. You must use your own good judgement.

You will find important safety information in a variety of forms, including:

- Safety labels on the motorcycle
- Safety Messages preceded by a safety alert symbol and one of three signal words: DANGER, WARNING, or CAUTION. These signal words mean:

DANGER

You **WILL** be **KILLED** or **SERIOUSLY HURT** if you don't follow instructions.

WARNING

You **CAN** be **KILLED** or **SERIOUSLY HURT** if you don't follow instructions.

CAUTION

You **CAN** be **HURT** if you don't follow instructions.

Other important information is provided under the following titles:

NOTICE Information to help you avoid damage to your motorcycle, other property, or the environment.

Contents

Motorcycle Safety P. 2

Operation Guide P. 18

Maintenance P. 47

Troubleshooting P. 93

Information P. 115

Specifications P. 129

Index P. 132

Motorcycle Safety

This section contains important information for safe riding of your motorcycle.
Please read this section carefully.

Safety Guidelines	P. 3
Image Labels	P. 6
Safety Precautions	P. 11
Riding Precautions	P. 12
Accessories & Modifications	P. 16
Loading	P. 17

Safety Guidelines

Follow these guidelines to enhance your safety:

- Perform all routine and regular inspections specified in this manual.
- Stop the engine and keep sparks and flame away before filling the fuel tank.
- Do not run the engine in enclosed or partly enclosed areas. Carbon monoxide in exhaust gases is toxic and can kill you.

Always Wear a Helmet

It's a proven fact: helmets and protective apparel significantly reduce the number and severity of head and other injuries. So always wear an approved motorcycle helmet and protective apparel. ➤ P. 11

Before Riding

Make sure that you are physically fit, mentally focused and free of alcohol and drugs. Check

that you and your passenger are both wearing an approved motorcycle helmet and protective apparel. Instruct your passenger on holding onto the grab rails or your waist, leaning with you in turns, and keeping their feet on the footpegs, even when the motorcycle is stopped.

Take Time to Learn & Practice

Even if you have ridden other motorcycles, practice riding in a safe area to become familiar with how this motorcycle works and handles, and to become accustomed to the motorcycle's size and weight.

Ride Defensively

Always pay attention to other vehicles around you, and do not assume that other drivers see you. Be prepared to stop quickly or perform an evasive maneuver.

Make Yourself Easy to See

Make yourself more visible, especially at night, by wearing bright reflective clothing, positioning yourself so other drivers can see you, signaling before turning or changing lanes, and using your horn when necessary.

Ride within Your Limits

Never ride beyond your personal abilities or faster than conditions warrant. Fatigue and inattention can impair your ability to use good judgement and ride safely.

Don't Drink and Ride

Alcohol and riding don't mix. Even one alcoholic drink can reduce your ability to respond to changing conditions, and your reaction time gets worse with every additional drink. Don't drink and ride, and don't let your friends drink and ride either.

Keep Your Honda in Safe Condition

It's important to keep your motorcycle properly maintained and in safe riding condition. Inspect your motorcycle before every ride and perform all recommended maintenance. Never exceed load limits (➤ P. 17), and do not modify your motorcycle or install accessories that would make your motorcycle unsafe (➤ P. 16).

If You are Involved in a Crash

Personal safety is your first priority. If you or anyone else has been injured, take time to assess the severity of the injuries and whether it is safe to continue riding. Call for emergency assistance if needed. Also follow applicable laws and regulations if another person or vehicle is involved in the crash.

If you decide to continue riding, first evaluate the condition of your motorcycle. If the engine is still running, turn it off. Inspect for fluid leaks,

check the tightness of critical nuts and bolts, and check the handlebar, control levers, brakes, and wheels. Ride slowly and cautiously. Your motorcycle may have suffered damage that is not immediately apparent. Have your motorcycle thoroughly checked at a qualified service facility as soon as possible.

Carbon Monoxide Hazard

Exhaust contains poisonous carbon monoxide, a colourless, odorless gas. Breathing carbon monoxide can cause loss of consciousness and may lead to death.

If you run the engine in a confined or even partly enclosed area, the air you breathe could contain a dangerous amount of carbon monoxide. Never run your motorcycle inside a garage or other enclosure.

WARNING

Carbon monoxide gas is toxic.
Breathing it can cause
unconsciousness and even kill you.

Avoid any areas or activities that
expose you to carbon monoxide.

Image Labels

The following pages describe the label meanings. Some labels warn you of potential hazards that could cause serious injury. Others provide important safety information. Read this information carefully and don't remove the labels.

If a label comes off or becomes hard to read, contact your dealer for a replacement.

There is a specific symbol on each label. The meanings of each symbol and label are as follows.



Read instructions contained in Owner's Manual carefully.



Read instructions contained in Shop Manual carefully. In the interest of safety, take the motorcycle to be serviced only by your dealer.



DANGER (with RED background)

You **WILL** be **KILLED** or **SERIOUSLY HURT** if you don't follow instructions.

WARNING (with ORANGE background)

You **CAN** be **KILLED** or **SERIOUSLY HURT** if you don't follow instructions.

CAUTION (with YELLOW background)

You **CAN** be **HURT** if you don't follow instructions.



BATTERY LABEL

DANGER

- Keep flame and spark away from the battery. Battery produce explosive gas that can cause explosion.
- Wear the eye protection and rubber gloves when handling the battery, or you can get burned or lose your eyesight by the battery electrolyte.
- Do not allow children and other people to touch a battery unless they understand proper handling and hazards of the battery very well.
- Handle the battery electrolyte with extreme care as it contains dilute sulfuric acid. Contact with your skin or eyes can burn you or cause loss of your eyesight.
- Read this manual carefully and understand it before handling the battery. Neglect of the instructions can cause personal injury and damage to the motorcycle.
- Do not use a battery with the electrolyte at or below the lower level mark. It can explode causing serious injury.



RADIATOR CAP LABEL

DANGER

NEVER OPEN WHEN HOT.

Hot coolant will scald you.

Relief pressure valve begins to open at **108 kPa**.

ACCESSORIES AND LOADING WARNING LABEL

WARNING

ACCESSORIES AND LOADING

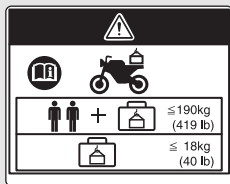

- The safety stability and handling of this motorcycle may be affected by the addition of accessories and luggage.
- Read carefully the instructions contained in user's manual and installation guide before installing any accessory.
- The total weight of accessories and luggage added to rider's and passenger's weight should not exceed **190 kg (419 lb)**, which is the maximum weight capacity.
- The luggage weight must not exceed **18 kg (40 lb)** under any circumstances.
- The fitting of large fork-mounted or large handlebar mounted fairing is not recommended.

**REAR CUSHION LABEL**

GAS FILLED

Do not open. Do not heat.

TYRE INFORMATION LABEL

Cold tyre pressure:

[Driver only]

Front **250 kPa (2.50 kgf/cm², 36 psi)**Rear **290 kPa (2.90 kgf/cm², 42 psi)**

[Driver and passenger]

Front **250 kPa (2.50 kgf/cm², 36 psi)**Rear **290 kPa (2.90 kgf/cm², 42 psi)**

Tyre size:

Front **120/70ZR17M/C(58W)**Rear **180/55ZR17M/C(73W)**

Tyre brand: DUNLOP BRIDGESTONE

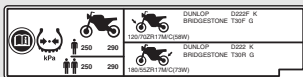
Front **D222F K T30F G**Rear **D222 K T30R G**



SAFETY REMINDER LABEL

For your protection, always wear helmet, protective apparel.

FUEL LABEL

Unleaded petrol only



DRIVE CHAIN LABEL

Keep chain adjusted and lubricated.

25 to 35 mm (1.0 to 1.4 in) Freeplay

Safety Precautions

- Ride cautiously and keep your hands on the handlebars and feet on the footpegs.
- Keep passenger's hands onto the grab rails or your waist, passenger's feet on the footpegs while riding.
- Always consider the safety of your passenger, as well as other drivers and riders.

Protective Apparel

Make sure that you and any passenger are wearing an approved motorcycle helmet, eye protection, and high-visibility protective clothing. Ride defensively in response to weather and road conditions.

■ Helmet

Safety-standard certified, high-visibility, correct size for your head.

- Must fit comfortably but securely, with the chin strap fastened.

- Face shield with unobstructed field of vision or other approved eye protection.

WARNING

Not wearing a helmet increases the chance of serious injury or death in a crash.

Make sure that you and any passenger always wear an approved helmet and protective apparel.

■ Gloves

Full-finger leather gloves with high abrasion resistance

■ Boots or Riding Shoes

Sturdy boots with non-slip soles and ankle protection

■ Jacket and Trousers

Protective, highly visible, long-sleeved jacket and durable trousers for riding (or a protective suit).

Riding Precautions

Running-in Period

During the first 500 km (300 miles) of running, follow these guidelines to ensure your motorcycle's future reliability and performance.

- Avoid full-throttle starts and rapid acceleration.
- Avoid hard braking and rapid down-shifts.
- Ride conservatively.

Brakes

Observe the following guidelines:

- Avoid excessively hard braking and down-shifts.
 - ▶ Sudden braking can reduce the motorcycle's stability.
 - ▶ Where possible, reduce speed before turning; otherwise you risk sliding out.
- Exercise caution on low traction surfaces.
 - ▶ The tyres slip more easily on such surfaces and braking distances are longer.
- Avoid continuous braking.
 - ▶ Repeated braking, such as when descending long, steep slopes can seriously overheat the brakes, reducing their effectiveness. Use engine braking with intermittent use of the brakes to reduce speed.
- For full braking effectiveness, operate both the front and rear brakes together.

■ Anti-lock Brake System (ABS)

This model is equipped with an Anti-lock Brake System (ABS) designed to help prevent the brakes from locking up during hard braking.

- ABS does not reduce braking distance. In certain circumstances, ABS may result in a longer stopping distance.
- ABS does not function at speeds below 10 km/h (6 mph).
- The brake lever and pedal may recoil slightly when applying the brakes. This is normal.
- Always use the recommended tyres to ensure correct ABS operation.

■ Engine Braking

Engine braking helps slow your motorcycle down when you release the throttle. For further slowing action, downshift to a lower gear. Use engine braking with intermittent use of the brakes to reduce speed when descending long, steep slopes.

■ Wet or Rainy Conditions

Road surfaces are slippery when wet, and wet brakes further reduce braking efficiency. Exercise extra caution when braking in wet conditions.

If the brakes get wet, apply the brakes while riding at low speed to help them dry.

Parking

- Park on a firm, level paved surface.
- If you must park on a slight incline or loose surface, park so that the motorcycle cannot move or fall over.
- Make sure that high-temperature parts cannot come into contact with flammable materials.
- Do not touch the engine, muffler, brakes and other high-temperature parts until they cool down.
- To reduce the likelihood of theft, always lock the handlebars and remove the key when leaving the motorcycle unattended. Use of an anti-theft device is also recommended.

▮ Parking with the Side Stand or Centre Stand

1. Stop the engine.
2. **Using the side stand**
Push the side stand down.

Slowly lean the motorcycle to the left until its weight rests on the side stand.

Using the centre stand

Let down the centre stand, stand on the left side of the motorcycle. Hold the left handle grip and the left grab rail. Press down on the tip of the stand with your right foot and, simultaneously, pull up and back.

3. Turn the handlebars fully to the left.
▶ Turning the handlebars to the right reduces stability and may cause the motorcycle to fall.
4. Turn the ignition switch to the LOCK position and remove the key. ➡ P. 38

Refuelling and Fuel Guidelines

Follow these guidelines to protect the engine and catalytic converter:

- Use only unleaded petrol.
- Use recommended octane number. Using lower octane petrol will result in decreased engine performance.
- Do not use fuels containing a high concentration of alcohol. ➤ P. 120
- Do not use stale or contaminated petrol or an oil/petrol mixture.
- Avoid getting dirt or water in the fuel tank.

TCS (Traction Control System)

TCS (Traction Control System) assists you in maintaining traction while accelerating on slippery surfaces by regulating the engine's power output when it senses the rear wheel starting to lose traction.

TCS does not work in case of rear wheel lock caused by a sudden closing of the throttle. Do not close the throttle suddenly especially on the slippery road surface.

TCS may not compensate rough condition of roads or rapid and improper throttle operations. Always ride with a sufficient caution to the road and weather conditions.

In certain unusual conditions when your motorcycle gets stuck in shallow mud or fresh snow, it may be easier to free it with the TCS temporarily switched off.

It may also help to make it easier to maintain the balance and control in such condition as riding in an off-road terrain.

Always use the recommended tyres and sprockets to ensure correct TCS operation.

Accessories & Modifications

We strongly advise that you do not add any accessories that were not specifically designed for your motorcycle by Honda or make modifications to your motorcycle from its original design. Doing so can make it unsafe. Modifying your motorcycle may also void your warranty and make your motorcycle illegal to operate on public roads and highways. Before deciding to install accessories on your motorcycle be certain the modification is safe and legal.

WARNING

Improper accessories or modifications can cause a crash in which you can be seriously hurt or killed.

Follow all instructions in this owner's manual regarding accessories and modifications.

Do not pull a trailer with, or attach a sidecar to, your motorcycle. Your motorcycle was not designed for these attachments, and their use can seriously impair your motorcycle's handling.

Loading

- Carrying extra weight affects your motorcycle's handling, braking and stability. Always ride at a safe speed for the load you are carrying.
- Avoid carrying an excessive load and keep within specified load limits.
 - ✘ **Maximum weight capacity / Maximum luggage weight** P. 129
- Tie all luggage securely, evenly balanced and close to the centre of the motorcycle.
- Do not place objects near the lights or the muffler.

WARNING

Overloading or improper loading can cause a crash and you can be seriously hurt or killed.

Follow all load limits and other loading guidelines in this manual.

Parts Location

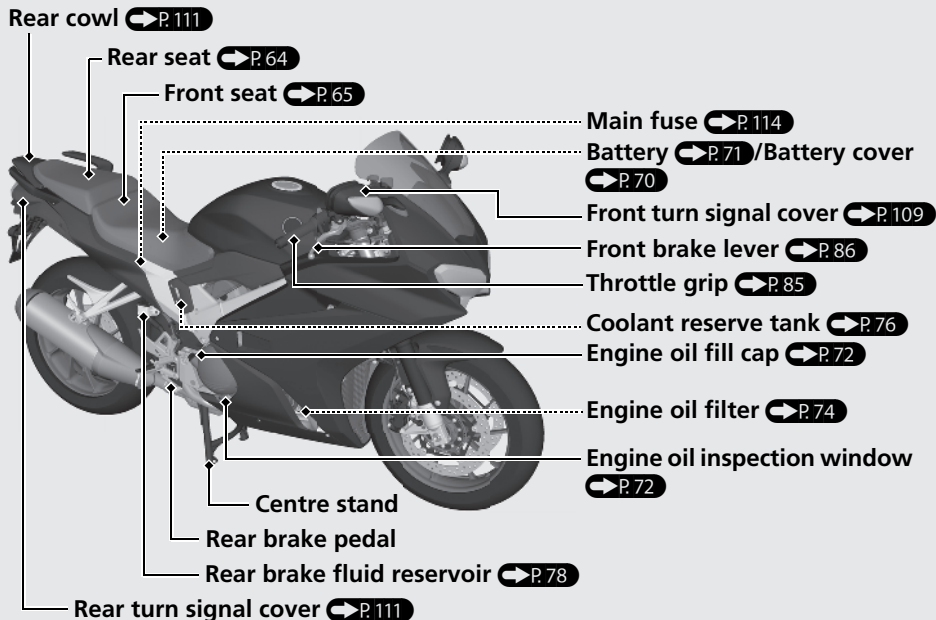

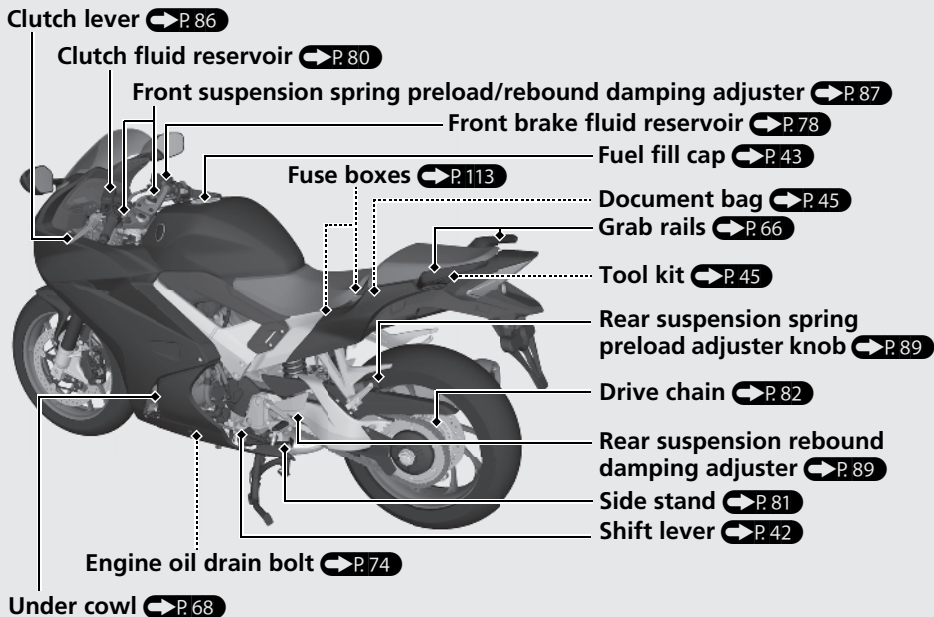

Instruments

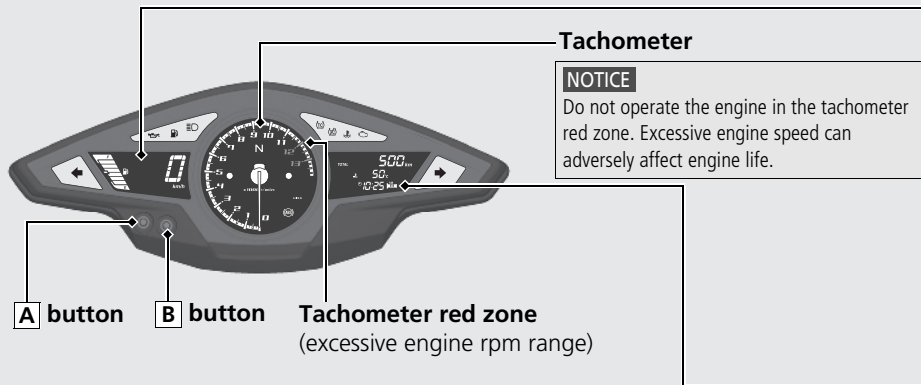

Display Check

When the ignition switch is turned on, all the mode and digital segments will show. If any part of these displays does not come on when it should, have your dealer check for problems.

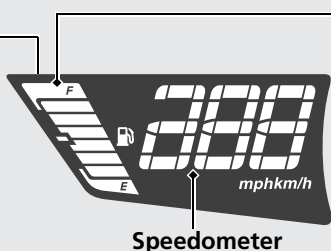

Speedometer

Fuel gauge

Remaining fuel when only 1st (E) segment starts flashing:
approximately 3.8 litres
(1.00 US gal, 0.84 Imp gal)



If the fuel gauge indicators repeat flashing or turned off: ➔ P. 99

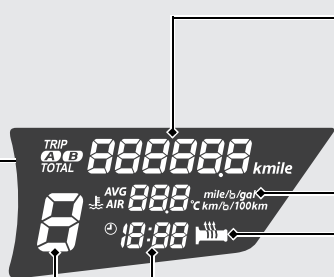

Gear position indicator

➔ P. 23

Odometer [TOTAL] & Tripmeter [TRIP A/B] & Mileage countdown ➔ P. 22

Fuel mileage meter/Average speed/Coolant temperature gauge/Air temperature gauge
➔ P. 24

Handle grip heater status icon

The handle grip heater status icon will appear while the handle grip heater is on.

Clock (12-hour display)/Trip time/
Handle grip heater level ➔ P. 28

Instruments *(Continued)*

Odometer [TOTAL] & Tripmeter [TRIP A/B] & Mileage countdown



Odometer [TOTAL] & Tripmeter [TRIP A/B] & Mileage countdown

A button switches between the odometer, the tripmeter A, the tripmeter B and the mileage countdown.

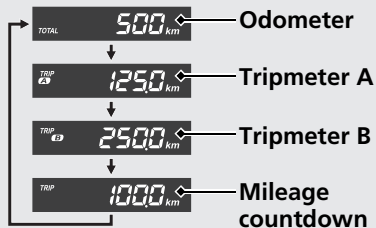

Odometer

Total distance ridden. When "-----" is displayed, go to your dealer for service.

Tripmeter

Distance ridden since tripmeter was reset. When "----.-" is displayed, go to your dealer for service.

To reset the tripmeter: P.27

Mileage countdown

Distance travelled is subtracted from a preset figure.

Display range: 999.9 to 0.0 km or mph

When the countdown value reaches "0.0" km or mile while riding, the number will flash.

If an indication other than the mileage countdown is displayed, the indication automatically switches to the mileage countdown and flashes "0.0" km or mile.

- ▶ To reset the mileage countdown distance, press and hold **A** button when mileage countdown is displayed.
- ▶ When changing the unit to “km” after setting the trip distance to “625 mile” or more with the unit set to “mile” unit, the thousands place digit is not displayed because the distance exceeds the maximum display range.

To set the mileage countdown:  **P.33**

Gear position indicator

Shows 1st to 6th gear position.

When the ignition switch is turned on with the transmission in 3rd gear or higher, the gear position indicator will be displayed as shown in the illustration.



After the transmission is shifted to 2nd gear, the gear position indication will display the correct gear position.

Always use the recommended tyres and sprockets to ensure correct gear position indication.

Instruments *(Continued)*

Fuel mileage meter & Average speed & Coolant temperature gauge & Air temperature gauge



Fuel mileage meter & Average speed & Coolant temperature gauge & Air temperature gauge

B button switches between the current fuel mileage, the average fuel mileage, the average speed, the coolant temperature gauge and the air temperature gauge.

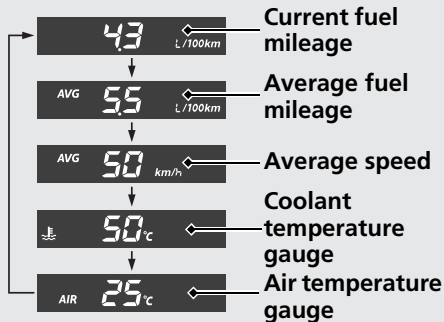

Current fuel mileage

Displays the current or instant fuel mileage.

Display range: 0.1 to 99.9 km/L (L/100km, mile/L or mile/gal)

- When your speed is less than 7 km/h (5 mph): "--.-" is displayed
- Less than 0.1 km/L (L/100km, mile/L or mile/gal) or 99.9 km/L (L/100km, mile/L or mile/gal) or more : "--.-" is displayed

When "--.-" is displayed except for the above-mentioned case, go to your dealer for service.

Average fuel mileage

Displays the average fuel mileage since the selected tripmeter was reset.

The average fuel mileage will be calculated based on value displayed on the tripmeter (A or B) selected. Also, the average fuel mileage for tripmeter A will be displayed when the odometer or the mileage countdown is selected.

Display range: 0.1 to 99.9 km/L (L/100km, mile/L or mile/gal)

- Initial display: "--.-" is displayed
- Less than 0.1 km/L (L/100km, mile/L or mile/gal) or 99.9 km/L (L/100km, mile/L or mile/gal) or more : "--.-" is displayed
- When the tripmeter A or B is reset: "--.-" is displayed

When "--.-" is displayed except for the above-mentioned case, go to your dealer for service.

To reset the average fuel mileage:



Instruments *(Continued)*

Average speed

Displays the average speed since the selected tripmeter was reset.

The average speed will be calculated based on value displayed on the tripmeter (A or B) selected. Also, the average speed for tripmeter A will be displayed when the odometer or the mileage countdown is selected.

- Initial display: "---" is displayed
When "---" is displayed while riding, go to your dealer for service.

To reset the average speed:  **P.27**

Coolant temperature gauge ()

Display range: 35 to 132 °C

- Below 34 °C: "--" displays
- Between 122 and 131 °C:
 - High coolant temperature indicator lights

- Coolant temperature gauge (flashing digits)

- Above 132 °C:
 - High coolant temperature indicator lights
 - "132" (°C) flashes
 - ▶ Even if the engine coolant temperature is low, the cooling fan may start running when you rev up the engine. This is normal.

Air temperature gauge (AIR)

Display range: -10 to 50 °C

- Below -11 °C: "--" displays
- Above 50 °C:
 - "50" (°C) flashes
 - ▶ The temperature readout may be incorrect at low speeds due to reflected heat.

To reset the tripmeter, average fuel mileage and average speed

To reset tripmeter A, average fuel mileage and average speed (these are based on tripmeter A) together, press and hold **A** button while tripmeter A is displayed.

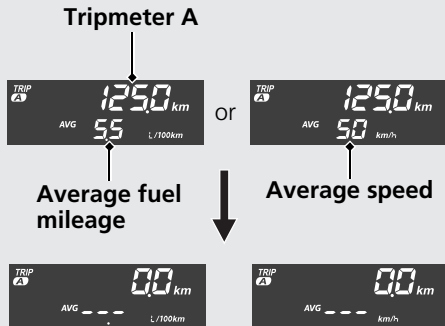

To reset tripmeter B, average fuel mileage and average speed (these are based on tripmeter B) together, press and hold **B** button while tripmeter B is displayed.

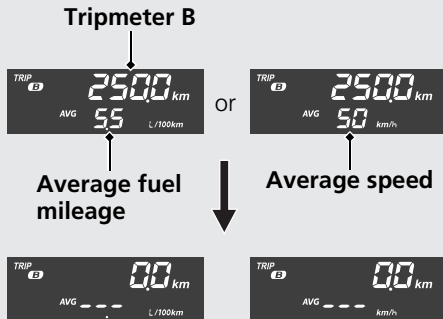

Instruments *(Continued)*

Clock (12-hour display) & Trip time & Handle grip heater level



Clock (12-hour display) & Trip time & Handle grip heater level

You can switch the modes between clock and trip time mode by pressing and holding **B** button.

Clock

Handle grip heater level



Trip time

→ Press and hold **B** button.

⇒ The heater level is displayed for about 5 seconds when the handle grip heater is on or its level is changed.

Clock

To set the clock: P. 30

Trip time

Displays the time elapsed since the engine was started.

Display range: 0:00 to 19:59 (hours:minutes)
The display returns to 0:00 when the time elapsed exceeds 19:59.

Handle grip heater level

When you operate the handle grip heater, the clock or trip time automatically switch to the indication for the heater level. The display will return to the ordinary mode after about 5 seconds.

To operate the handle grip heater:

P. 40

Display Setting

Following items to change sequentially.

- Clock setting
- Backlight brightness adjustment
- HISS indicator setting
- Changing the speed and mileage unit
- Changing the fuel mileage meter unit
- Setting the mileage countdown

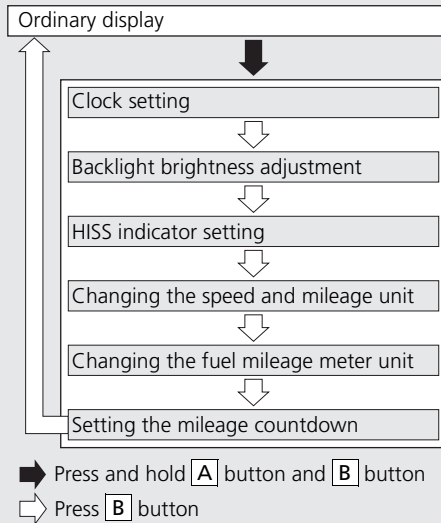

Instruments *(Continued)*

If the ignition switch is turned off, the button is not pressed for about 30 seconds, or the handle grip heater level is changed, the control is automatically switched from the setting mode to the ordinary display. Only items that have been set are applied.

1 Clock setting:

- 1 Turn the ignition switch ON.
- 2 Press and hold **A** button and **B** button, the hour digits start flashing.
- 3 Press **A** button until the desired hour is displayed.
 - ▶ Press and hold **A** button to advance the hour fast.



- 4 Press **B** button. The minute digits start flashing.



- 5 Press **A** button until the desired minute is displayed.
 - ▶ Press and hold **A** button to advance the minute fast.



- 6 Press **B** button. The clock is set, and then the display moves to the backlight brightness adjustment.

2 Backlight brightness adjustment:

You can adjust the brightness to one of five levels.

- 1 Press **A** button. The brightness is switched.

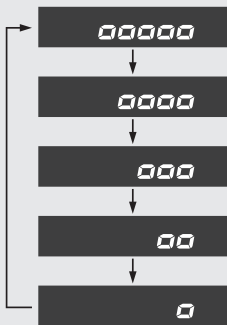

- 2 Press **B** button. The backlight is set, and then the display moves to the on/off of blinks of HISS indicator (HISS indicator comes on).

3 HISS indicator setting:

You can select the blink or off the HISS indicator.

- 1 Press **A** button to select "On" (blinks) or "OFF" (off).



- 2 Press **B** button. The HISS indicator setting is set, and then the display moves to the changing of the speed and mileage unit.

Instruments *(Continued)*

4 Changing the speed and mileage unit:

- 1 Press **A** button to select either "km/h" & "km" or "mph" & "mile".



- 2 Press **B** button. The speed and mileage unit is set, and then the display moves to the changing of the fuel mileage meter unit.

5 Changing the fuel mileage meter unit:

- 1 Press **A** button to select "L/100km" or "km/L".



If the "mph" for speed and "mile" for mileage are selected, the fuel mileage shown by "mile/L" or "mile/gal".



- 2 Press **B** button. The fuel mileage meter unit is set, and then the display moves to the setting of mileage countdown.

6 Setting the mileage countdown:

- 1 The preset figure is displayed and the third digit will be flashing.



- 2 To set the third digit, press **A** button until the desired figure appears.
 - ▶ Press and hold **A** button to advance the figure fast.
- 3 Press **B** button. The second digit starts flashing.



- 4 Repeat the steps 2 and 3 for the second and first digits.
- 5 Press **B** button. The trip distance is set, and then the display will return to the ordinary display.

The trip distance will not be reset when you complete setting of the mileage countdown by pressing **B** button only or when you set the trip distance to the same as the current distance.

When entering the setting mode using "km" unit after setting the trip distance to "625 mile" or more with the unit set to "mile", "---.-" will appear because the distance exceeds the maximum display range.

Press **A** button to display "000.0", and then set the trip distance again if necessary. Pressing **B** button while "---.-" is displayed will return the display to the ordinary display and keep the previous trip distance.

Indicators

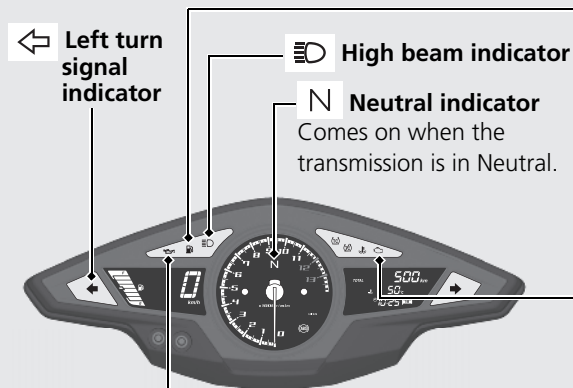

 **Left turn signal indicator**

 **High beam indicator**

 **Neutral indicator**
Comes on when the transmission is in Neutral.



 **Low oil pressure indicator**
Comes on when the ignition switch is turned on.
Goes off when the engine starts.

If it comes on while engine is running:  **P. 96**

 **Low fuel indicator**

- Comes on briefly when the ignition switch is turned on.
- Comes on when there is only reserve fuel left in the fuel tank. Remaining fuel when low fuel indicator comes on:
3.8 litres (1.00 US gal,
0.84 Imp gal)

 **PGM-FI (Programmed Fuel Injection) malfunction indicator lamp (MIL)**

Comes on briefly when the ignition switch is turned on with the engine stop switch in the  (Run) position. Comes on when the ignition switch is turned on with the engine stop switch in the  (Off) position.

If it comes on while engine is running:  **P. 96**

(TCS OFF) **TCS (Traction Control System) OFF indicator**

Comes on when the TCS is turned off.

(TCS) **TCS (Traction Control System) indicator**

- Comes on when the ignition switch is turned on. Goes off when your speed reaches approximately 10 km/h (6 mph) to indicate TCS is ready to work.
- Blinks when TCS is operating.

If it comes on while riding: ➔ P.98

(TEMP) **High coolant temperature indicator**

Comes on briefly when the ignition switch is turned on.

If it comes on while riding: ➔ P.95

(TURN) **Right turn signal indicator**

(HISS) **HISS indicator** ➔ P.117

- Comes on briefly when the ignition switch is turned on with the engine stop switch in the (Run) position. Goes off if the ignition key has the correct coding.
- Flashes every 2 seconds for 24 hours when the ignition switch is turned off.

(ABS) **ABS (Anti-lock Brake System) indicator**

Comes on when the ignition switch is turned on. Goes off when your speed reaches approximately 10 km/h (6 mph).

If it comes on while riding: ➔ P.97

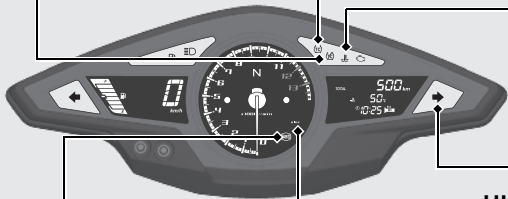

Switches



TCS (Traction Control System) OFF switch

Press and hold to turn the TCS on and off.

- The TCS OFF indicator comes on when TCS is turned off.

Passing light control switch

Flashes the high beam headlight.

Headlight dimmer switch

- : High beam
- : Low beam



Handle grip heater switch

➡ P. 39



Turn signal switch

- The turn signal will automatically stop when you complete the turn.
- When used for a lane change, the turn signal is automatically stopped in 7 seconds or after riding 120 m (131 yards).
- ▶ You can manually cancel the turn signal by pressing the switch in.
- ▶ In some cases, the timing at which the turn signal stops is changed.
- ▶ Always use the recommended tyres to ensure correct automatic cancellation operation.

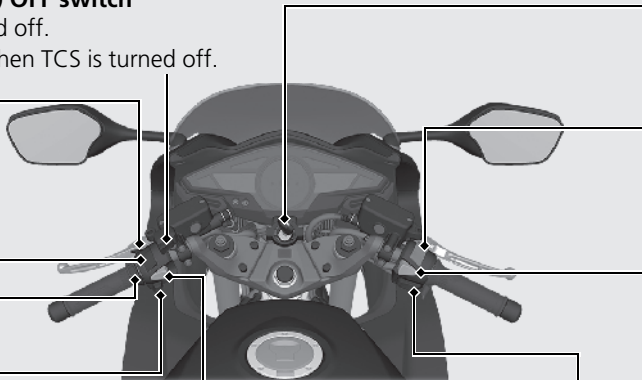



Ignition Switch

Switches the electrical system on/off, locks the steering.

- ▶ Key can be removed when in the OFF or LOCK position.

Engine stop switch

Should normally remain in the  (Run) position.

- ▶ In an emergency, switch to the  (Off) position (the starter motor will not operate) to stop the engine.



Hazard switch

Switchable when the ignition switch is on. Can be turned to off regardless of the ignition switch position.

- ▶ The signals continue flashing with the ignition switch in OFF or LOCK after the hazard switch is on.



Start button

Headlight turns off when operating the starter motor.



Horn button

Switches *(Continued)*

Steering Lock

Lock the steering when parking to help prevent theft.

A U-shaped wheel lock or similar device is also recommended.

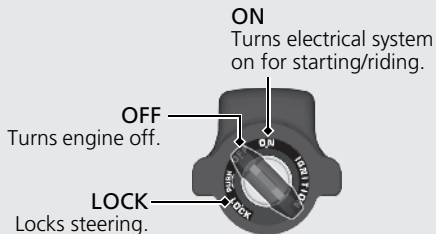
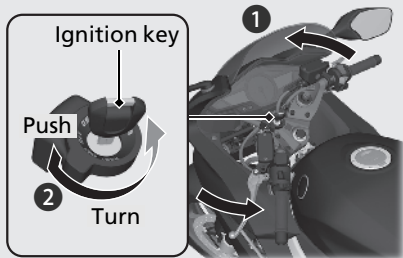

Locking

- 1 Turn the handlebars all the way to the left or right.
- 2 Push the key down, and turn the ignition switch to the LOCK position.
 - ▶ Jiggle the handlebars if the lock is difficult to engage.
- 3 Remove the key.

Unlocking

Insert the key, push it in, and turn the ignition switch to the OFF position.

Handle Grip Heater

VFR800F is equipped with a handle grip heater that warms up your hands during ride. Wear gloves to protect your hands from the heated grips.

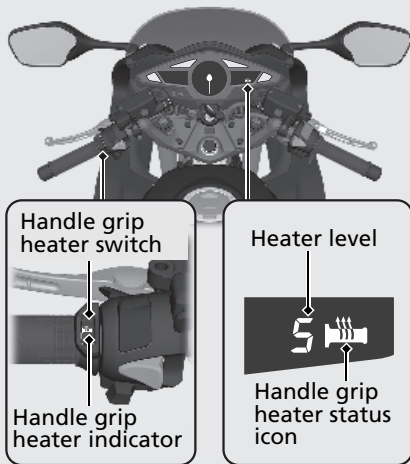

Handle grip heater indicator:

Displayed when the handle grip heater is on. The selected heater level is indicated by the number of times the indicator blinks when the heater is turned on and the heater level is changed. For example, If you select heater level 5, the indicator blinks 5 times and repeats it 7 times.

Heater level:

The selected heater level is indicated for a few seconds when the handle grip heater switch is operated.

Handle grip heater status icon:

Displayed when the handle grip heater is on.

|| If the "E1", "E2" or "E3" blinks: → P.99



Handle Grip Heater *(Continued)*

To operate the handle grip heater

- ➊ Start the engine. ➤ P. 41
- ➋ Press the handle grip heater switch. The handle grip heater is on.
 - ▶ The status icon will be appeared on the display when the handle grip heater operates.
- ➌ Select the heater level by pressing the switch.
 - ▶ The clock or trip time on the display automatically switch to the indication of the heater level. The indication will return to the ordinary mode after blinking for about 5 seconds.
 - ▶ Do not leave the handle grip heater in the high position for a long time on a warm day.
- ➍ To turn off the heater, press the switch until the status icon on the display is disappeared. Also to turn off, press and hold the switch.

Do not use the handle grip heater with the engine at idle for a long time. It may result in

a low (or dead) battery.

Maintains the selected level when the ignition switch is turned off.

- ▶ The heater level is not changed if the ignition switch is turned to the OFF position within 5 seconds after heater level change.

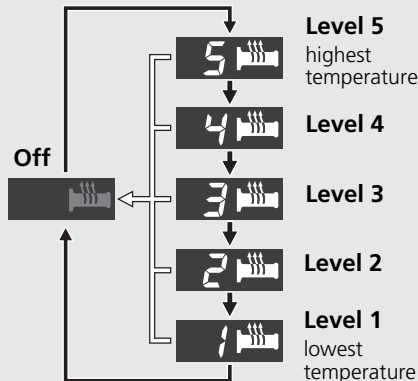

➔ Press the handle grip heater switch.

➞ Press and hold the handle grip heater switch.

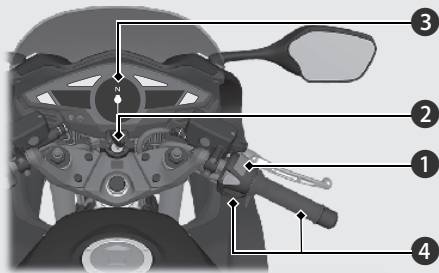

Starting the Engine

Start your engine using the following procedure, regardless of whether the engine is cold or warm.



NOTICE

- If the engine does not start within 5 seconds, turn the ignition off and wait 10 seconds before trying to start the engine again to recover battery voltage.
- Extended fast idling and revving the engine can damage the engine, and the exhaust system.
- Snapping the throttle or fast idling for more than about 5 minutes may cause exhaust pipe discoloration.
- The engine will not start if the throttle is fully open.

- 1 Make sure the engine stop switch is in the  (Run) position.
- 2 Turn the ignition switch to the ON position.
- 3 Shift the transmission to Neutral ( indicator comes on). Alternatively, pull in the clutch lever to start your motorcycle with the transmission in gear so long as the side stand is raised.
- 4 Press the start button with the throttle completely closed.

If the engine does not start:

- 1 Open the throttle fully and press the start button for 5 seconds.
- 2 Repeat the normal starting procedure.
- 3 If the engine starts, open the throttle slightly if idling is unstable.
- 4 If the engine does not start, wait 10 seconds before trying steps 1 & 2 again.

If Engine Will Not Start  P.94

Shifting Gears

Your motorcycle transmission has six forward gears in a one-down, five-up shift pattern.

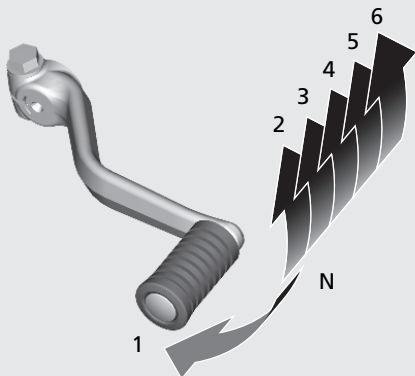

If you put the motorcycle in gear with the side stand down, the engine will shut off.

Refuelling

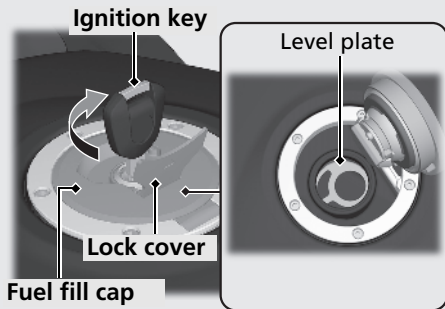

Do not fill with fuel above the level plate.

Fuel type: Unleaded petrol only

Fuel octane number: Your motorcycle is designed to use Research Octane Number (RON) 91 or higher.

Tank capacity: 21.2 litres (5.60 US gal, 4.66 Imp gal)

Refuelling and Fuel Guidelines ➔ P.15

Opening the Fuel Fill Cap

Open the lock cover, insert the ignition key, and turn it clockwise to open the cap.

Closing the Fuel Fill Cap

- 1 After refuelling, push the fuel fill cap closed until it locks.
- 2 Remove the key and close the lock cover.
 - ▶ The key cannot be removed if the cap is not locked.

⚠ WARNING

Petrol is highly flammable and explosive. You can be burned or seriously injured when handling fuel.

- Stop the engine, and keep heat, sparks, and flame away.
- Handle fuel only outdoors.
- Wipe up spills immediately.

Storage Equipment

Helmet Holder

The helmet holder is located under the rear seat. The helmet set wire is stored in the tool kit.  P. 45

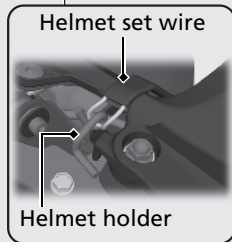
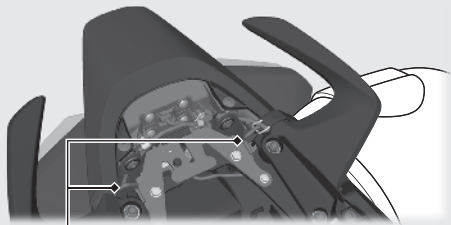

► Use the helmet holder only when parked.

▮ **Removing the Rear Seat**  P. 64

WARNING

Riding with a helmet attached to the holder can interfere with the rear wheel or suspension and could cause a crash in which you can be seriously hurt or killed.

Use the helmet holder only while parked. Do not ride with a helmet secured by the holder.

Tool Kit/Document Bag

The tool kit is located under the rear seat. Secure the tool kit with the rubber strap as shown in the illustration. The document bag is located under the front seat.

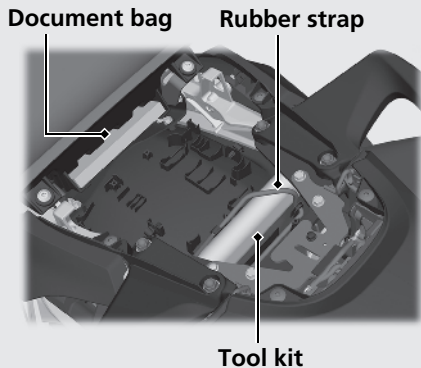

Removing the Rear Seat ➔ P.64

U-shaped Lock

A U-shaped lock is held in place above the rear fender.

When storing the U-shaped lock, first remove the rubber strap that secures the tool kit. Next, place the U-shaped lock and tool kit onto the rear fender as shown in the illustration, and then secure them with the rubber strap.

► Some U-shaped locks may not fit in the compartment due to their size or design.

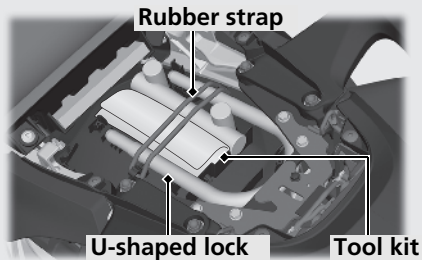

Removing the Rear Seat ➔ P.64

Storage Equipment *(Continued)*

Luggage Tie-down Hook

The luggage tie-down hooks are located on the underside of the rear seat.

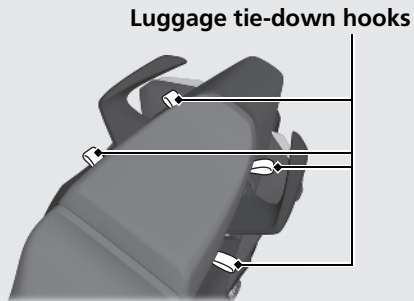
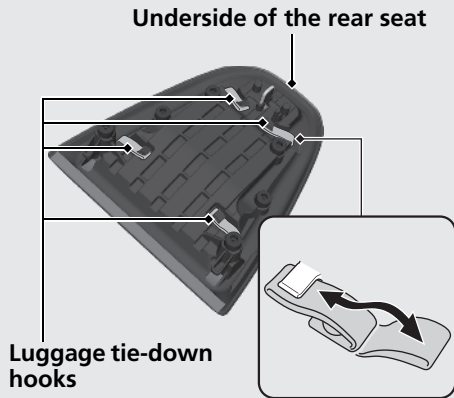

Never use the tie-down hooks to tow or lift the motorcycle.

Removing the Rear Seat ➔ P. 64

Maintenance

Please read “Importance of Maintenance” and “Maintenance Fundamentals” carefully before attempting any maintenance. Refer to “Specifications” for service data.

Importance of Maintenance	P. 48	Engine Oil	P. 72
Maintenance Schedule	P. 49	Coolant	P. 76
Maintenance Fundamentals	P. 52	Brakes/Clutch	P. 78
Tool kit	P. 63	Side Stand	P. 81
Removing & Installing Body Components ...	P. 64	Drive Chain	P. 82
Rear Seat	P. 64	Throttle	P. 85
Front Seat	P. 65	Other Adjustments	P. 86
Single Seat Cowl.....	P. 66	Clutch and Brake Levers	P. 86
Under Cowl	P. 68	Front Suspension	P. 87
Clip.....	P. 69	Rear Suspension	P. 89
Battery Cover.....	P. 70	Headlight Aim	P. 90
Battery.....	P. 71	Front Seat Height	P. 91

Importance of Maintenance

Importance of Maintenance

Keeping your motorcycle well-maintained is absolutely essential to your safety and to protect your investment, obtain maximum performance, avoid breakdowns, and reduce air pollution. Maintenance is the owner's responsibility. Be sure to inspect your motorcycle before each ride, and perform the periodic checks specified in the Maintenance Schedule. ➤ P. 49

WARNING

Improperly maintaining your motorcycle or failing to correct a problem before you ride can cause a crash in which you can be seriously hurt or killed.

Always follow the inspection and maintenance recommendations and schedules in this owner's manual.

Maintenance Safety

Always read the maintenance instructions before you begin each task, and make sure that you have the tools, parts, and skills required. We cannot warn you of every conceivable hazard that can arise in performing maintenance. Only you can decide whether or not you should perform a given task.

Follow these guidelines when performing maintenance.

- Stop the engine and remove the key.
- Park your motorcycle on a firm, level surface using the side stand, centre stand or a maintenance stand to provide support.
- Allow the engine, muffler, brakes, and other high-temperature parts to cool before servicing as you can get burned.
- Run the engine only when instructed, and do so in a well-ventilated area.

Maintenance Schedule









The maintenance schedule specifies the maintenance requirements necessary to ensure safe, dependable performance, and proper emission control.

Maintenance work should be performed in accordance with Honda's standards and specifications by properly trained and equipped technicians. Your dealer meets all of these requirements. Keep an accurate record of maintenance to help ensure that your motorcycle is properly maintained. Make sure that whomever performs the maintenance completes this record.



All scheduled maintenance is considered a normal owner operating cost and will be charged for by your dealer. Retain all receipts. If you sell the motorcycle, these receipts should be transferred with the motorcycle to the new owner.

Honda recommends that your dealer should road test your motorcycle after each periodic maintenance is carried out.

Maintenance Schedule





















































































Items	Pre-ride Check P. 52	Odometer Reading *1						Annual Check	Regular Replace	Refer to page
		x 1,000 km	1	12	24	36	48			
		x 1,000 mi	0.6	8	16	24	32			
Fuel Line				I	I	I	I	I		-
Fuel Level		I								-
Throttle Operation		I		I	I	I	I	I		85
Air Cleaner *2					R		R			-
Spark Plug					I		R			-
Valve Clearance					I		I			-
Engine Oil		I	R	R	R	R	R	R	R	72
Engine Oil Filter			R	R	R	R	R	R	R	74
Engine Idle Speed			I	I	I	I	I	I		-
Radiator Coolant *3		I		I	I	I	I	I	3 Years	76
Cooling System				I	I	I	I	I		-
Secondary Air Supply System					I		I			-

Maintenance Level

-  : Intermediate. We recommend service by your dealer, unless you have the necessary tools and are mechanically skilled. Procedures are provided in an official Honda Shop Manual.
-  : Technical. In the interest of safety, have your motorcycle serviced by your dealer.

Maintenance Legend

- I** : Inspect (clean, adjust, lubricate, or replace, if necessary)
- L** : Lubricate
- R** : Replace

Items	Pre-ride Check  P. 52	Odometer Reading *1						Annual Check	Regular Replace	Refer to page
		x 1,000 km	1	12	24	36	48			
		x 1,000 mi	0.6	8	16	24	32			
Drive Chain		Every 1,000 km (600 mi):   								82
Drive Chain Slider										84
Brake Fluid *3									2 Years	78
Brake Pads Wear										79
Brake System										52
Brakelight Switch										80
Headlight Aim										90
Lights/Horn										-
Engine Stop Switch										-
Clutch System										52
Clutch fluid *3									2 Years	80
Side Stand										81
Suspension										87
Nuts, Bolts, Fasteners										-
Wheels/Tyres	 									60
Steering Head Bearings	 									-

Notes:

*1 : At higher odometer readings, repeat at the frequency interval established here.

*2 : Service more frequently when riding in unusually wet or dusty areas.

*3 : Replacement requires mechanical skill.

Pre-ride Inspection

To ensure safety, it is your responsibility to perform a pre-ride inspection and make sure that any problem you find is corrected. A pre-ride inspection is a must, not only for safety, but because having a breakdown, or even a flat tyre, can be a major inconvenience.

Check the following items before you get on your motorcycle:

- Fuel level-Fill fuel tank when necessary. ➤ P. 43
- Throttle-Check for smooth opening and full closing in all steering positions. ➤ P. 85
- Engine oil level-Add engine oil if necessary. Check for leaks. ➤ P. 72
- Coolant level-Add coolant if required. Check for leaks. ➤ P. 76
- Drive chain-Check condition and slack, adjust and lubricate if necessary. ➤ P. 57, 82
- Brakes-Check operation; Front and Rear: check brake fluid level and pads wear. ➤ P. 78
- Lights and horn-Check that lights, indicators and horn function properly.
- Engine stop switch-Check for proper function.
- Clutch-Check clutch fluid level. ➤ P. 80
- Side stand ignition cut-off system-Check for proper function. ➤ P. 81
- Wheels and tyres-Check condition, air pressure and adjust if necessary. ➤ P. 60

Replacing Parts

Always use Honda Genuine Parts or their equivalents to ensure reliability and safety. When ordering coloured components, specify the model name, colour, and code mentioned on the colour label. The colour label is attached to the rear fender under the rear seat. 📄 P. 64

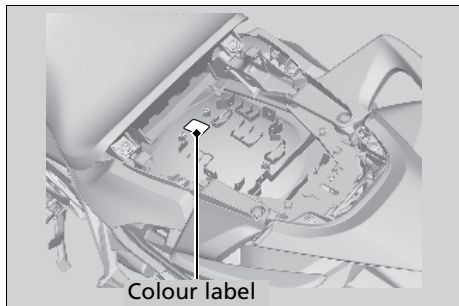

⚠️ WARNING

Installing non-Honda parts may make your motorcycle unsafe and cause a crash in which you can be seriously hurt or killed.

Always use Honda Genuine Parts or equivalents that have been designed and approved for your motorcycle.

Battery

Your motorcycle has a maintenance-free type battery. You do not have to check the battery electrolyte level or add distilled water. Clean the battery terminals if they become dirty or corroded.

Do not remove the battery cap seals. There is no need to remove the cap when charging.

NOTICE

Your battery is a maintenance-free type and can be permanently damaged if the cap strip is removed.



This symbol on the battery means that this product must not be treated as household waste.

NOTICE

An improperly disposed of battery can be harmful to the environment and human health.

Always confirm local regulations for battery disposal.

WARNING

The battery gives off explosive hydrogen gas during normal operation.

A spark or flame can cause the battery to explode with enough force to kill or seriously hurt you.

Wear protective clothing and a face shield, or have a skilled mechanic do the battery servicing.

I Cleaning the Battery Terminals

1. Remove the battery.  P. 71
2. If the terminals are starting to corrode and are coated with a white substance, wash with warm water and wipe clean.

3. If the terminals are heavily corroded, clean and polish the terminals with a wire brush or sandpaper. Wear safety glasses.

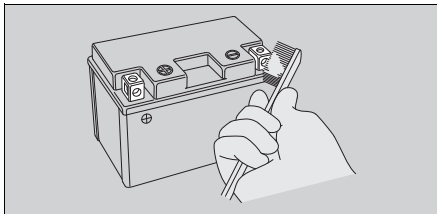

4. After cleaning, reinstall the battery.

The battery has a limited life span. Consult your dealer about when you should replace the battery. Always replace the battery with another maintenance-free battery of the same type.

NOTICE

Installing non-Honda electrical accessories can overload the electrical system, discharging the battery and possibly damaging the system.

Fuses

Fuses protect the electrical circuits on your motorcycle. If something electrical on your motorcycle stops working, check for and replace any blown fuses. P. 113

Inspecting and Replacing Fuses

Turn off the ignition switch to remove and inspect fuses. If a fuse is blown, replace with a fuse of the same rating. For fuse ratings, see "Specifications." P. 131

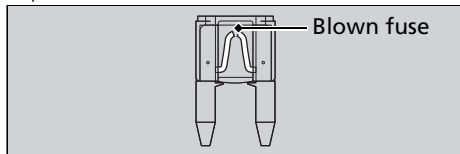

NOTICE

Replacing a fuse with one that has a higher rating greatly increases the chance of damage to the electrical system.

Maintenance Fundamentals

If a fuse fails repeatedly, you likely have an electrical fault. Have your motorcycle inspected by your dealer.

Engine Oil

Engine oil consumption varies and oil quality deteriorates according to riding conditions and time elapsed.

Check the engine oil level regularly, and add the recommended engine oil if necessary. Dirty oil or old oil should be changed as soon as possible.

Selecting the Engine Oil

For recommended engine oil, see "Specifications". ➤ P. 130

If you use non-Honda engine oil, check the label to make sure that the oil satisfies all of the following standards:

- JASO T 903 standard*1: MA
- SAE standard*2: 10W-30
- API classification*3: SG or higher

- *1. The JASO T 903 standard is an index for engine oils for 4-stroke motorcycle engines. There are two classes: MA and MB. For example, the following label shows the MA classification.

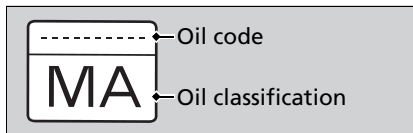

- *2. The SAE standard grades oils by their viscosity.
- *3. The API classification specifies the quality and performance rating of engine oils. Use SG or higher oils, excluding oils marked as "Energy Conserving" or "Resource Conserving" on the circular API service symbol.

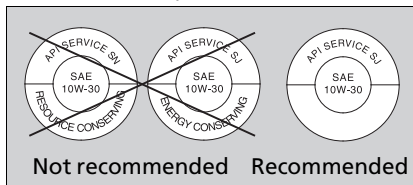

Brake Fluid (Clutch Fluid)

Do not add or replace brake fluid, except in an emergency. Use only fresh brake fluid from a sealed container. If you do add fluid, have the brake and clutch system serviced by your dealer as soon as possible.

NOTICE

Brake fluid can damage plastic and painted surfaces. Wipe up spills immediately and wash thoroughly.

Recommended brake fluid:

Honda DOT 4 Brake Fluid or equivalent

Drive Chain

The drive chain must be inspected and lubricated regularly. Inspect the chain more frequently if you often ride on bad roads, ride at high speed, or ride with repeated fast acceleration.

If the chain does not move smoothly, makes strange noises, has damaged rollers or loose pins or missing O-rings, or kinks, have the chain inspected by your dealer.

Also inspect the engine sprocket and rear wheel sprocket. If either has worn or damaged teeth, have the sprocket replaced by your dealer.

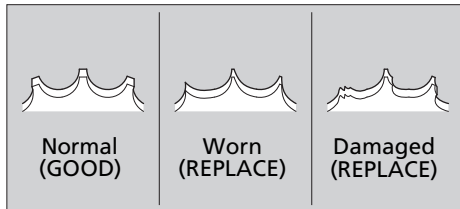

NOTICE

Use of a new chain with worn sprockets will cause rapid chain wear.

I Cleaning and Lubricating

After inspecting the slack, clean the chain and sprockets while rotating the rear wheel. Use a dry cloth with chain cleaner designed specifically for O-ring chains, or neutral detergent. Use a soft brush if the chain is dirty. After cleaning, wipe dry and lubricate with the recommended lubricant. If not available, use SAE 80 or 90 gear oil.

Recommended lubricant:

Drive chain lubricant designed specifically for O-ring chains.
If not available, use SAE 80 or 90 gear oil.

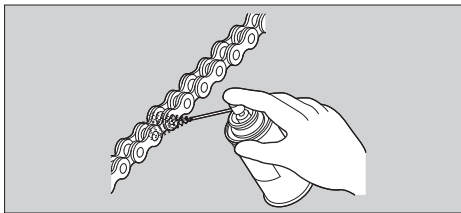

Do not use a steam cleaner, a high pressure cleaner, a wire brush, volatile solvent such as petrol and benzene, abrasive cleaner, chain cleaner or lubricant NOT designed specifically for O-ring chains as these can damage the rubber O-ring seals.

Avoid getting lubricant on the brakes or tyres. Avoid applying excess chain lubricant to prevent spray onto your clothes and the motorcycle.

Recommended Coolant

Pro Honda HP is a pre-mixed solution of antifreeze and distilled water.

Concentration:

50 % antifreeze and 50 % distilled water

A concentration of antifreeze below 40 % will not provide proper corrosion and cold temperature protection. A concentration of up to 60 % will provide better protection in colder climates.

NOTICE

Using coolant not specified for aluminium engines or using ordinary tap water can cause corrosion.

Air Cleaner

This motorcycle is equipped with a viscous type air cleaner element.

Compressed air cleaning or any other cleaning can degrade the viscous element performance and cause the intake of dust.

Do not perform the maintenance.

Should be serviced by your dealer.

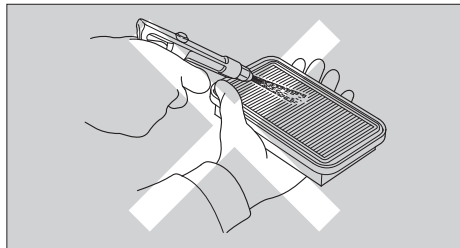

Tyres (Inspecting/Replacing)

Checking the Air Pressure

Visually inspect your tyres and use an air pressure gauge to measure the air pressure at least once a month or any time you think the tyres look low. Always check air pressure when your tyres are cold.

Inspecting for Damage

Inspect the tyres for cuts, slits, or cracks that exposes fabric or cords, or nails or other foreign objects embedded in the side of the tyre or the tread. Also inspect for the bumps or bulges in the side walls of the tyres.

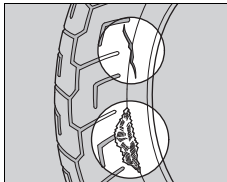

Inspecting for Abnormal Wear

Inspect the tyres for signs of abnormal wear on the contact surface.

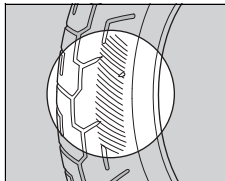

Inspecting Tread Depth

Inspect the tread wear indicators. If they become visible, replace the tyres immediately. For safe riding, you should replace the tyres when the minimum tread depth is reached.

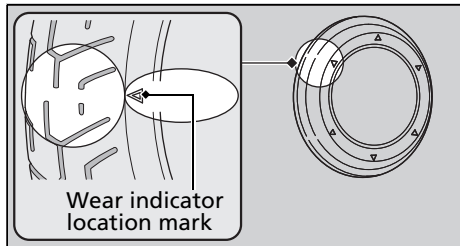

⚠️ WARNING

Riding on tyres that are excessively worn or improperly inflated can cause a crash in which you can be seriously hurt or killed.

Follow all instructions in this owner's manual regarding tyre inflation and maintenance.

Germany

German law prohibits use of tyres whose tread depth is less than 1.6 mm.

Maintenance Fundamentals

Have your tyres replaced by your dealer. For recommended tyres, air pressure and minimum tread depth, see “Specifications”.

➤ P. 130

Follow these guidelines whenever you replace tyres.

- Use the recommended tyres or equivalents of the same size, construction, speed rating, and load range.
- Have the wheel balanced with Honda Genuine balance weights or equivalents after the tyre is installed.
- Do not install a tube inside a tubeless tyre on this motorcycle. Excessive heat build-up can cause the tube to burst.
- Use only tubeless tyres on this motorcycle. The rims are designed for tubeless tyres, and during hard acceleration or braking, a tube-type tyre could slip on the rim and cause the tyre to rapidly deflate.

WARNING

Installing improper tyres on your motorcycle can adversely affect handling and stability, and can cause a crash in which you can be seriously hurt or killed.

Always use the size and type of tyres recommended in this owner's manual.

Tool kit

The tool kit is stored under the rear seat.

➔ P. 64

You can perform some roadside repairs, minor adjustments and parts replacement with the tools contained in the kit.

- Standard/Phillips screwdriver
- Screwdriver handle
- 14 × 17 mm Open end wrench
- Helmet set wire
- 5 mm Hex wrench
- Fuse puller
- Drive chain adjustment pin spanner
- Extension bar
- Front suspension spring preload adjustment spanner

Rear Seat

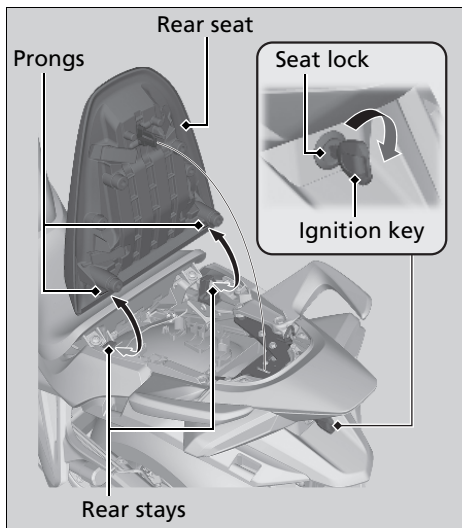

Removal

1. Insert the ignition key into the seat lock.
2. Turn it clockwise, then pull the rear seat up and back.

Installation

1. Insert the prongs into the rear stays on the frame.
2. Push down on the rear of the rear seat.
Make sure that the seat is locked securely in position to pull it up lightly.
The seat locks automatically when closed.
Take care not to lock your key in the compartment under the rear seat.

Front Seat

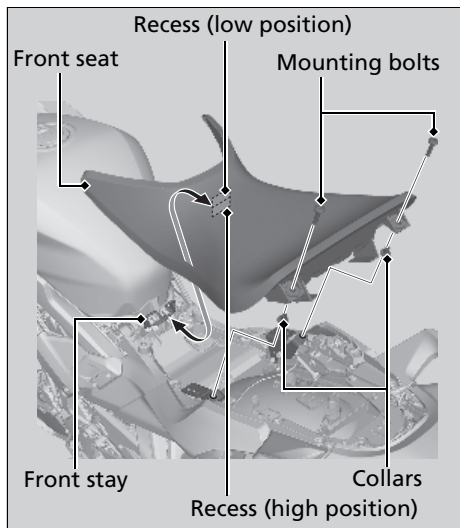

Removal

1. Remove the rear seat. ► P. 64
2. Remove the mounting bolts and collars, and then pull the front seat back and up.

Installation

1. Install the front seat by aligning the recess for the current seat height position (low or high) with the front stay.
2. Install the collars and mounting bolts.
3. Tighten the mounting bolts securely.
4. Make sure that the mount positions of the recess and the adjust plates are the same seat position. ► P. 92
5. Install the rear seat.
Make sure that the seat is locked securely in position to pull it up lightly.

For the front seat height adjustment, see “Changing the Front Seat Height.” ► P. 91

Single Seat Cowl

Installation of Single Seat Cowl

1. Remove the rear seat. ► P. 64
2. Remove the bolts.
3. Remove the grab rail mounting bolts/washers.
4. Remove the grab rails.

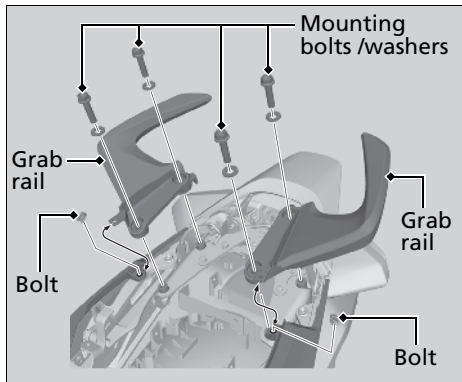

5. Install the grab rail covers.
6. Install and tighten the grab rail mounting bolts/washers.

Torque: 27 N·m (2.8 kgf·m, 20 lbf·ft).

7. Install and tighten the bolts securely.

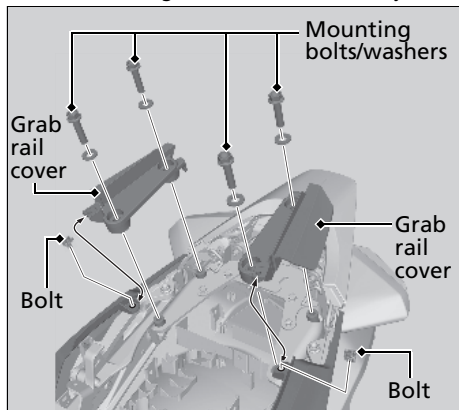

8. Install the single seat cowl in the same procedures of the rear seat installation.

► P. 64

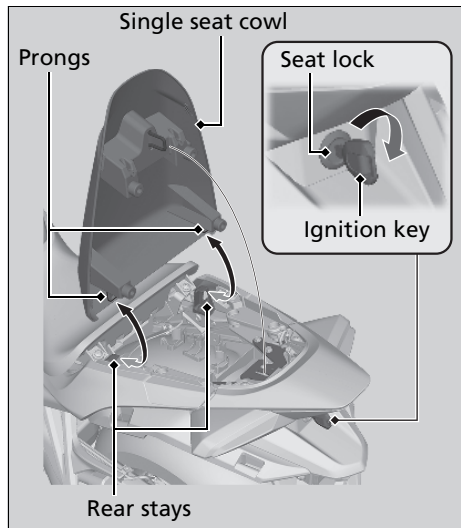

Make sure that the single seat cowl is locked securely in position to pull it up lightly. The seat locks automatically when closed. Take care not to lock your key in the compartment under the single seat cowl.

■ Removal of Single Seat Cowl

Removal can be done in the reverse order of installation.

- Tighten the grab rail mounting bolts.

Torque: 27 N·m (2.8 kgf·m, 20 lbf·ft).

Always reinstall the grab rails when reinstalling the rear seat.

If a torque wrench was not used for installation, see your dealer as soon as possible to verify proper assembly. The grab rail could come off easily and result in serious injury if not assembled properly.

Under Cowl

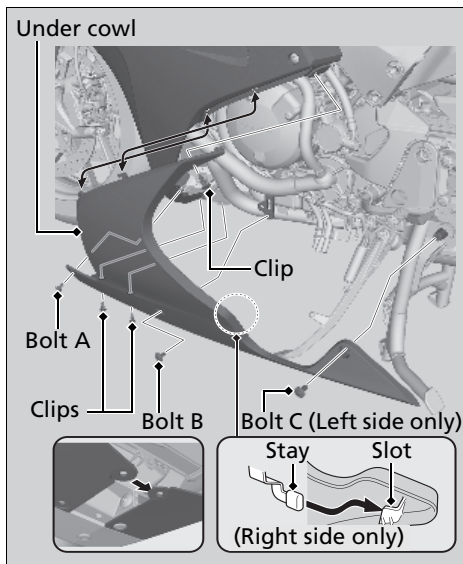

The right and left under cowls must be removed to replace the engine oil filter.

Removal

1. Park your motorcycle on its centre stand on a firm, level surface and lower the side stand.
2. Remove the clips on both sides. ► P. 69
3. Remove the bolt A and bolt B on both sides.
4. Remove the bolt C (left side only).
5. Remove the right and left under cowls while carefully releasing the tabs from the slots of each upper cowl and the slot of right under cowl from the stay.
 - Be careful not to apply weight to the under cowls.

Installation

Install the parts in the reverse order of removal.

Clip

The clip must be removed to remove the under cowl.

Removal

1. Press down on the centre pin to release the lock.
2. Pull the clip out of the hole.

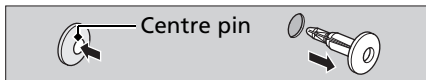

Installation

1. Push the bottom of the centre pin.

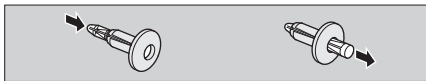

2. Insert the clip into the hole.
3. Press down on the centre pin to lock the clip.

Battery Cover

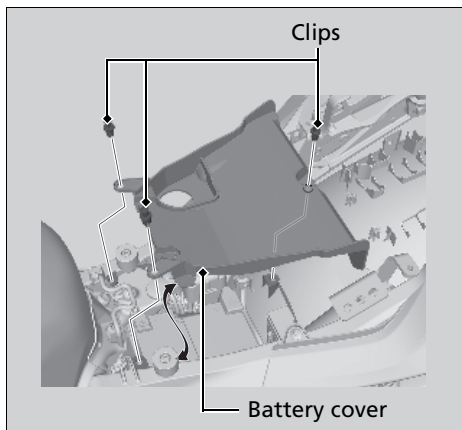

The battery cover must be removed to remove the battery, to service the main and fuse box fuses.

Removal

1. Remove the front seat. ► P. 65
2. Remove the clips.
3. Remove the battery cover.

Installation

Install the parts in the reverse order of removal.

Battery

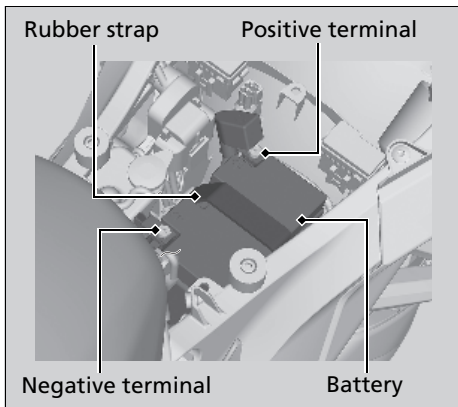

Removal

Make sure the ignition switch is off.

1. Remove the battery cover. ➤ P. 70
2. Unhook the rubber strap.

3. Disconnect the negative \ominus terminal from the battery.
4. Disconnect the positive \oplus terminal from the battery.
5. Remove the battery taking care not to drop the terminal nuts.

Installation

Install the parts in the reverse order of removal. Always connect the positive \oplus terminal first. Make sure that bolts and nuts are tight.

Readjust the clock after the battery is reconnected since the clock goes wrong once the battery disconnected.

For proper handling of the battery, see "Maintenance Fundamentals." ➤ P. 54
 "Battery Goes Dead." ➤ P. 107

Checking the Engine Oil

1. If the engine is cold, idle the engine for 3 to 5 minutes.
2. Turn the ignition switch off, stop the engine and wait 2 to 3 minutes.
3. Park your motorcycle on its centre stand on a firm, level surface.
4. Check that the oil level is between the upper and lower level marks in the oil level inspection window.

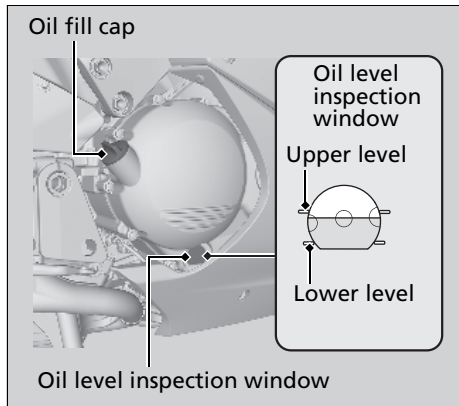

Adding Engine Oil

If the engine oil is below or near the lower level mark, add the recommended engine oil.

► P. 56

1. Remove the oil fill cap. Add the recommended oil until it reaches the upper level mark.
 - Park your motorcycle on its centre stand on a firm, level surface when checking the oil level.
 - Do not overfill above the upper level mark.
 - Make sure no foreign objects enter the oil filler opening.
 - Wipe up any spills immediately.

2. Securely reinstall the oil fill cap.

NOTICE

Overfilling with oil or operating with insufficient oil can cause damage to your engine. Do not mix different brands and grades of oil. They may affect lubrication and clutch operation.

For the recommended oil and oil selection guidelines, see "Maintenance Fundamentals." ► P. 56

Changing Engine Oil & Filter

Changing the oil and filter requires special tools. We recommend that you have your motorcycle serviced by your dealer.

Use a new Honda Genuine oil filter or equivalent specified for your model.

NOTICE

Using the wrong oil filter can result in serious damage to the engine.

1. Park your motorcycle on its centre stand on a firm, level surface.
2. Remove the right and left under cowls.
▶ P. 68
3. If the engine is cold, idle the engine for 3 to 5 minutes.
4. Turn the ignition switch off, stop the engine and wait for 2 to 3 minutes.
5. Place a drain pan under the drain bolt.

6. Remove the oil fill cap, drain bolt, and sealing washer to drain the oil.

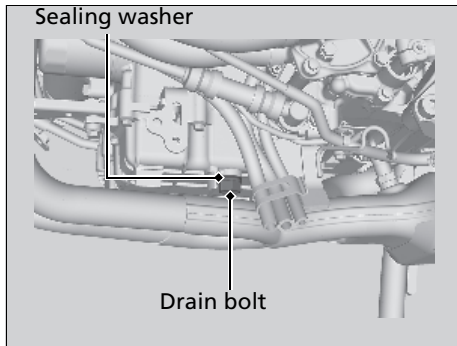

7. Loosen the oil filter with a filter wrench from the left side.
8. Remove the oil filter from the right side and let the remaining oil drain out.
 - Discard the oil and oil filter at an approved recycling centre.

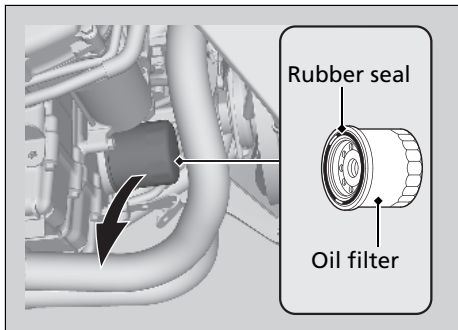

9. Apply a thin coat of engine oil to the rubber seal of a new oil filter.
10. Install a new oil filter and tighten.

Torque: 26 N·m (2.7 kgf·m, 19 lbf·ft).

11. Install a new sealing washer onto the drain bolt. Tighten the drain bolt.

Torque: 30 N·m (3.1 kgf·m, 22 lbf·ft).

12. Fill the crankcase with the recommended oil (► P. 56) and install the oil fill cap.

Required oil

When changing oil & engine oil filter:

3.1 litres (3.3 US qt, 2.7 Imp qt)

When changing oil only:

2.9 litres (3.1 US qt, 2.6 Imp qt)

13. Check the oil level. ► P. 72
14. Check that there are no oil leaks.
15. Install the right and left under cowls.

Checking the Coolant

1. Place your motorcycle on a firm, level surface.
2. Hold your motorcycle in an upright position.
3. Check that the coolant level is between the UPPER and LOWER level marks in the reserve tank.

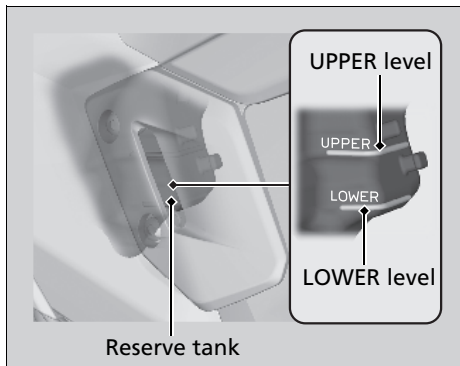

If the coolant level is dropping noticeably or the reserve tank is empty, you likely have a serious leak. Have your motorcycle inspected by your dealer.

Adding Coolant

If the coolant level is below the LOWER level, add the recommended coolant (➤ P. 58) until the level reaches the UPPER level mark. Add fluid only from the reserve tank cap and do not remove the radiator cap.

1. Remove the front seat. ➤ P. 65

2. Remove the reserve tank cap and add fluid while monitoring the coolant level.
 - Do not overfill above the UPPER level mark.
 - Make sure no foreign objects enter the reserve tank opening.
3. Securely reinstall the cap.
4. Install the front seat.

⚠ WARNING

Removing the radiator cap while the engine is hot can cause the coolant to spray out, potentially scalding you.

Always let the engine and radiator cool down before removing the radiator cap.

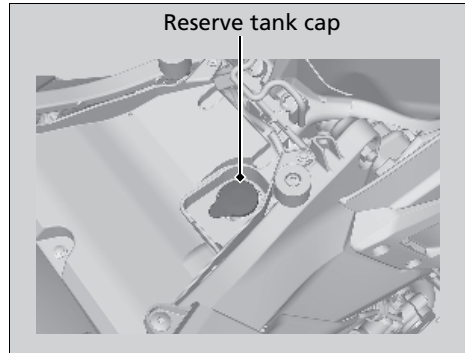

Changing Coolant

Have your dealer change the coolant unless you have the proper tools and are mechanically qualified.

Checking Brake Fluid

1. Place your motorcycle in an upright position on a firm, level surface.
2. **Front** Check that the brake fluid reservoir cap is horizontal and that the fluid level is above the LOWER level mark.
3. **Rear** Check that the brake fluid reservoir is horizontal and that the level is between the LOWER level and UPPER level marks.

If the brake fluid level in either reservoir is below the LOWER level mark or the brake lever and pedal freeplay becomes excessive, inspect the brake pads for wear. If the brake pads are not worn, you most likely have a leak. Have your motorcycle inspected by your dealer.

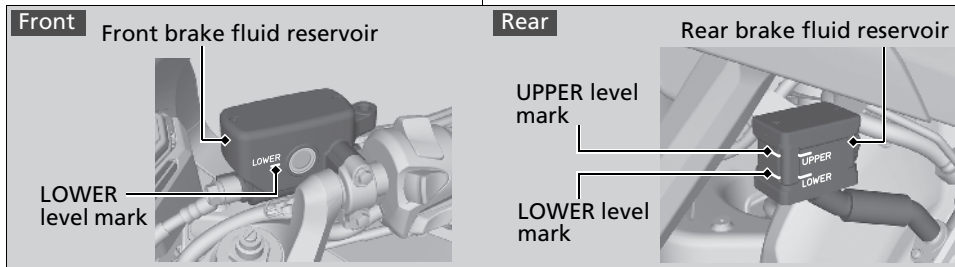

Inspecting the Brake Pads

Check the condition of the brake pad groove wear indicators.

The pads need to be replaced if a brake pad is worn to the bottom of the indicator.

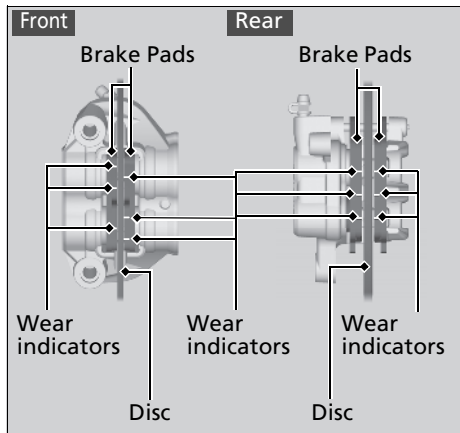

1. **Front** Inspect the brake pads from in front of the brake caliper.
 - Always inspect both left and right calipers.
2. **Rear** Inspect the brake pads from the rear right and left of the motorcycle.

If necessary have the pads replaced by your dealer.

Always replace both left and right brake pads at the same time.

Adjusting the Brakelight Switch

Check the operation of the brakelight switch. Turn the adjusting nut in the direction A if the switch operates too late, or turn the nut in the direction B if the switch operates too soon.

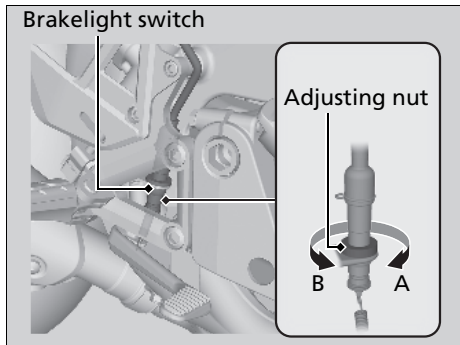

Checking the Clutch Fluid

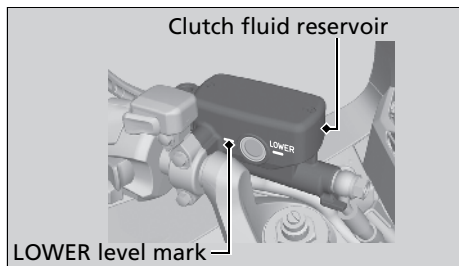

1. Place your motorcycle in an upright position on a firm, level surface.
2. Check that the clutch fluid reservoir cap is horizontal and that the fluid level is above the LOWER level mark.

If the fluid level is low or if you find fluid leaks, or deterioration or cracks in the hoses and fittings, have the clutch system serviced by your dealer.

Side Stand

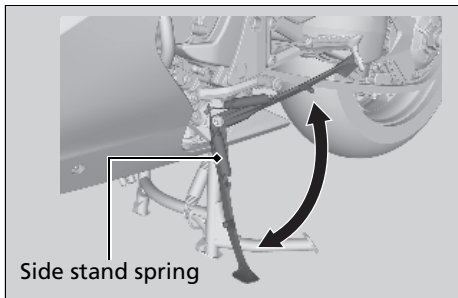

1. Check that the side stand operates smoothly. If the side stand is stiff or squeaky, clean the pivot area and lubricate the pivot bolt with clean grease.
2. Check the spring for damage or loss of tension.
3. Sit on the motorcycle, put the transmission in Neutral, and raise the side stand.
4. Start the engine, pull the clutch lever in, and shift the transmission into gear.
5. Lower the side stand all the way. The engine should stop as you lower the side stand. If the engine doesn't stop, have your motorcycle inspected by your dealer.

Inspecting the Drive Chain Slack

Check the drive chain slack at several points along the chain. If the slack is not constant at all points, some links may be kinked and binding.

Have the chain inspected by your dealer.

1. Stop the engine. Place the transmission in Neutral.
2. Place your motorcycle on the side stand on a level surface.

3. Check the slack in the lower half of the drive chain midway between the sprockets.

Drive chain slack:

25 to 35 mm (1.0 to 1.4 in)

- Do not ride your motorcycle if the slack exceeds 50 mm (2.0 in).

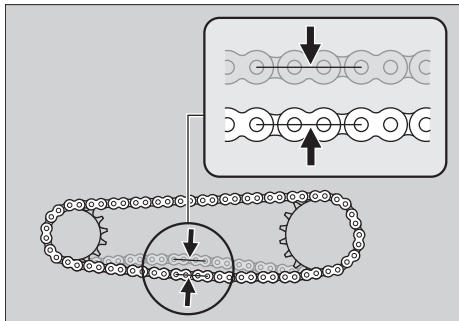

4. Roll the motorcycle forward and check that the chain moves smoothly.

5. Inspect the sprockets. 📄 P. 57
6. Clean and lubricate the drive chain. 📄 P. 58

Adjusting the Drive Chain Slack

Adjusting the chain requires special tools. Have the drive chain slack adjusted by your dealer.

1. Stop the engine. Place the transmission in Neutral.
2. Place your motorcycle on the side stand on a level surface.
3. Loosen the bearing holder pinch bolt.
4. Turn the bearing holder clockwise or counterclockwise to obtain the proper chain slack with the pin spanner and extension bar.

Drive Chain ▶ Adjusting the Drive Chain Slack

5. Tighten the bearing holder pinch bolt to the specified torque.

Torque: 88 N·m (9.0 kgf·m, 65 lbf·ft).

If a torque wrench was not used for this installation, see your dealer as soon as possible to verify proper assembly. Improper assembly may lead to loss of braking capacity.

6. Check drive chain slack. 📄 P. 82

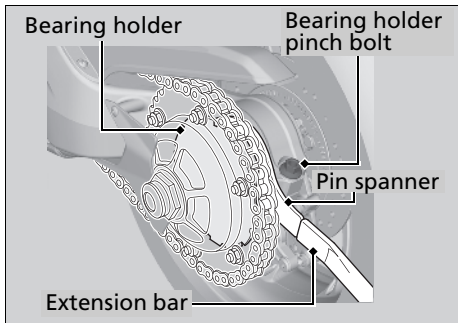

Checking the Drive Chain Wear

Check the chain wear label when adjusting the drive chain. If the red zone on the label aligns with the tip of driven sprocket teeth after the chain has been adjusted to the proper slack, the chain is excessively worn and must be replaced.

Chain:

DID 525HV3 or RK 525ROZ6

If necessary have the drive chain replaced by your dealer.

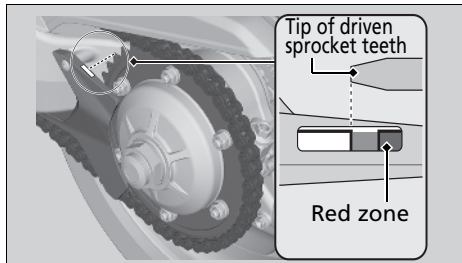

Checking the Drive Chain Slider

Check the condition of the drive chain slider. The drive chain slider need to be replaced if it is worn to the wear limit line.

If necessary have the drive chain slider replaced by your dealer.

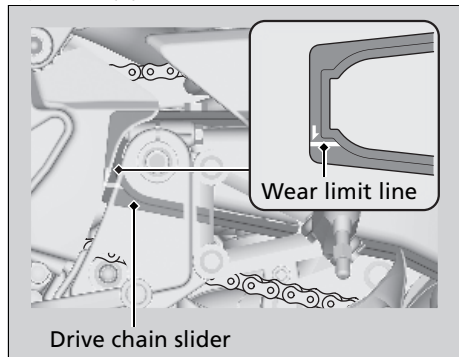

Checking the Throttle

With the engine off, check that the throttle rotates smoothly from fully closed to fully open in all steering positions and throttle freeplay is correct. If the throttle does not move smoothly, close automatically, or if the cable is damaged, have the motorcycle inspected by your dealer.

Freeplay at the throttle grip flange:

2 to 6 mm (0.1 to 0.2 in)

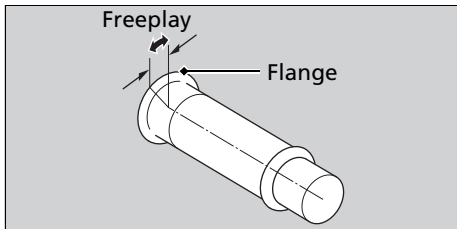

Adjusting the Clutch and Brake Levers

You can adjust the distances between the tip of the clutch lever and handle grip, and between the tip of the brake lever and handle grip.

Adjustment method

Turn the adjuster until the numbers align with the index mark while pushing the lever forward in the desired position.

After adjustment, check that the levers operate correctly before riding.

NOTICE

Do not turn the adjuster beyond its natural limit.

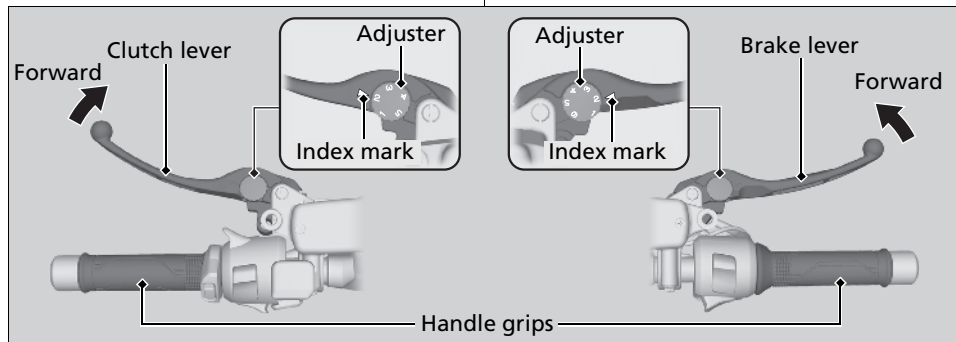

Adjusting the Front Suspension

Spring Preload

You can adjust the spring preload by the adjuster to suit the load or the road surface. Turn the adjuster using the preload spanner provided in the tool kit. ➤ 63

Turn clockwise to increase spring preload (hard), or turn counterclockwise to decrease spring preload (soft). The standard position is 4th groove from the top aligning with the top surface of the fork bolt.

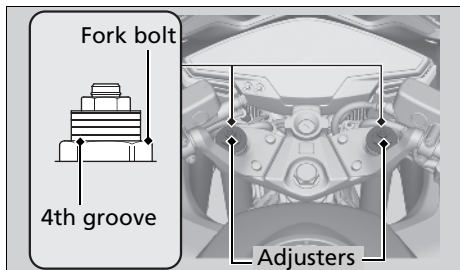

Rebound Damping

You can adjust the rebound damping by the adjuster to suit the load or the road surface. Turn clockwise to increase rebound damping (hard), or turn counterclockwise to decrease rebound damping (soft). The standard position is 1 turn from the maximum setting so that the punch mark on the adjuster aligns with the reference mark.

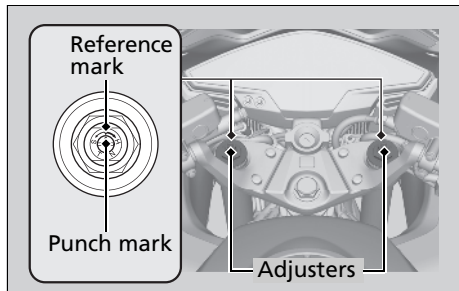

NOTICE

Do not turn the adjuster beyond its natural limits. Adjust both left and right forks to the same spring preload and rebound damping.

Adjusting the Rear Suspension

Spring Preload

You can adjust the spring preload by the adjuster knob to suit the load or the road surface. Turn clockwise to increase spring preload (hard), or turn counterclockwise to decrease spring preload (soft). The standard position is 7 clicks from the minimum setting.

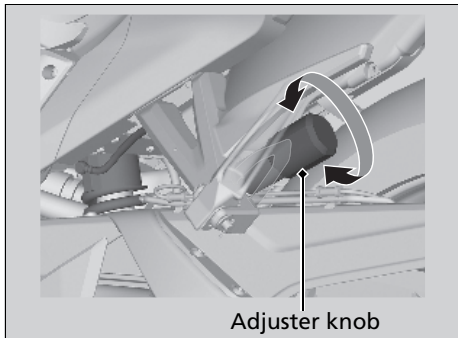

Rebound Damping

You can adjust the rebound damping by the adjuster to suit the load or the road surface. Turn clockwise to increase rebound damping (hard), or turn counterclockwise to decrease rebound damping (soft). The standard position is 3/4 turns from the maximum setting so that the punch mark on the adjuster aligns with the reference punch mark.

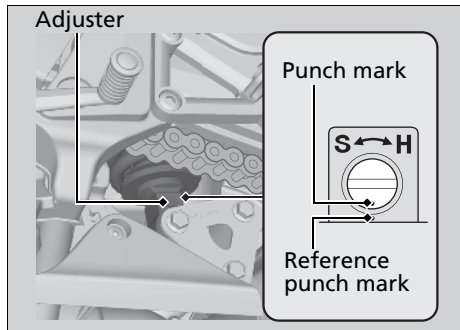

NOTICE

Do not turn the adjuster beyond its limits.

NOTICE

The rear shock absorber damper unit contains high pressure nitrogen gas. Do not attempt to disassemble, service, or improperly dispose of the damper. See your dealer.

Adjusting the Headlight Aim

You can adjust vertical aim of the headlight for proper alignment. Turn the knob in or out as necessary.

Obey local laws and regulations.

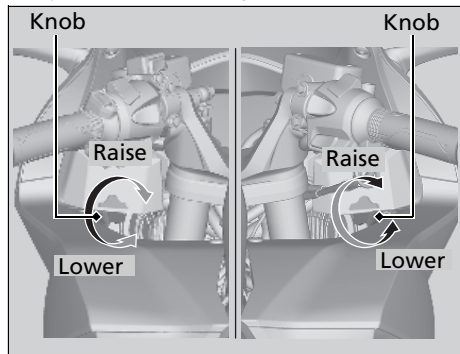

Changing the Front Seat Height

The front seat can be changed to one of two positions according to your preference. To change the seat height, use the proper hex wrench.

In the interest of safety, we recommend that you have your dealer perform the adjustment.

1. Remove the front seat. ► P. 65
2. Remove the socket bolts A and seat adjust plates.
3. Move the adjust plates and install the socket bolts A in the mounting holes for your preferred seat position (high or low), and then tighten them.

Torque: 22 N·m (2.2 kgf·m, 16 lbf·ft).

4. If you change the front seat height from high position to low position, remove the socket bolts B/set collars from the seat rail.

(The socket bolts B/set collars are not required for the low position.)

- Make sure to install the socket bolts B/set collars when the seat height is returned to the high position. Tighten the socket bolts B if reinstalling.

Torque: 12 N·m (1.2 kgf·m, 9 lbf·ft).

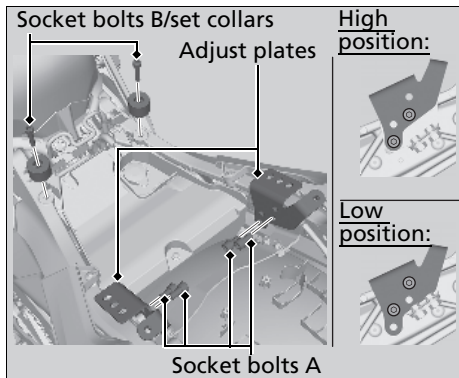

Other Adjustments ► Changing the Front Seat Height

5. Install the front seat. ► P. 65
► Align the recess for your preferred seat position (low or high) with the front stay.

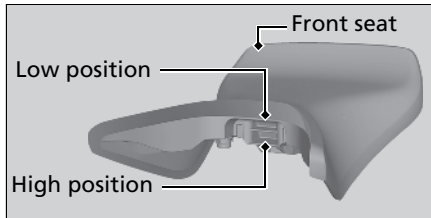

6. Make sure that the mount positions of the recess and the adjust plates are the same seat position.

High position:

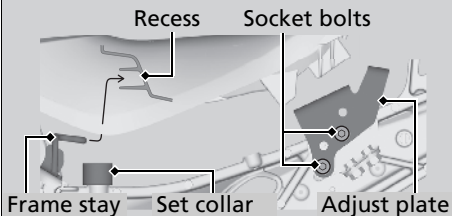

Low position:

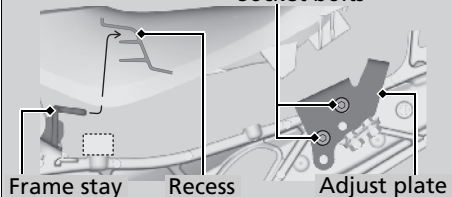

Troubleshooting

Engine Will Not Start (HISS indicator stays on).....	P. 94
Overheating (High coolant temperature indicator is on)	P. 95
Warning Indicators On or Flashing	P. 96
Low Oil Pressure Indicator	P. 96
PGM-FI (Programmed Fuel Injection)	
Malfunction Indicator Lamp (MIL).....	P. 96
ABS (Anti-lock Brake System) Indicator	P. 97
TCS (Traction Control System) Indicator	P. 98
Other Warning Indications.....	P. 99
Fuel Gauge Failure Indications	P. 99
Handle Grip Heater Failure Indication.....	P. 99
Tyre Puncture	P. 100
Electrical Trouble.....	P. 107
Battery Goes Dead	P. 107
Burned-out Light Bulb	P. 107
Blown Fuse.....	P. 113

Engine Will Not Start (HISS indicator stays on)

Starter Motor Operates But Engine Does Not Start

Check the following items:

- Check the correct engine starting sequence. ➤ P. 41
- Check that there is petrol in the fuel tank.
- Check if the PGM-FI malfunction indicator lamp (MIL) is on.
 - ▶ If the indicator light is on, contact your dealer as soon as possible.
- Check if the HISS indicator stays on.
 - ▶ Turn the ignition switch to the OFF position and remove the key. Reinsert the key and turn the ignition switch to the ON position. If the indicator still stays on, check the following:
Check if there is no another HISS key (including spare key) close to the ignition switch.

Check if there are no any metallic seals or stickers on the key.

If the HISS indicator still stays on, have your motorcycle inspected by your dealer.

Starter Motor Does Not Operate

Check the following items:

- Make sure engine stop switch is  (Run) position. ➤ P. 37
- Make sure the side stand is raised.
- Check for a blown fuse. ➤ P. 113
- Check for a loose battery connection or battery terminal corrosion. ➤ P. 71
- Check the condition of the battery. ➤ P. 107

If the problem continues, have your motorcycle inspected by your dealer.

Overheating (High coolant temperature indicator is on)

The engine is overheating when the following occurs:

- High coolant temperature indicator comes on.
- Acceleration becomes sluggish.

If this occurs, pull safely to the side of the road and perform the following procedure. Extended fast idling may cause the high coolant temperature indicator to come on.

NOTICE

Continuing to ride with an overheated engine can cause serious damage to the engine.

1. Stop the engine using the ignition switch, and then turn the ignition switch to the ON position.
2. Check that the radiator fan is operating, and then turn the ignition switch to the OFF position.
If the fan is not operating:
Suspect a fault. Do not start the engine. Transport your motorcycle to your dealer.
If the fan is operating:
Allow the engine to cool with the ignition switch in the OFF position.
3. After the engine has cooled, inspect the radiator hose and check if there is a leak.
➔ P. 76
If there is a leak:
Do not start the engine. Transport your motorcycle to your dealer.
4. Check the coolant level in the reserve tank, and add coolant as necessary.
➔ P. 76
5. If 1-4 check normal, you may continue riding, but closely monitor the temperature gauge.

Low Oil Pressure Indicator

If the low oil pressure indicator comes on, pull safely to the side of the road and stop the engine.

NOTICE

Continuing to ride with low oil pressure can cause serious damage to the engine.

1. Check the engine oil level, and add oil as necessary. ➤ P. 72
2. Start the engine.
 - ▶ Only continue riding if the low oil pressure indicator goes off.

Rapid acceleration may momentarily cause the low oil pressure indicator to come on, especially if the oil is at or near the low level. If the low oil pressure indicator stays on when the oil level is at the proper level, stop the engine and contact your dealer.

If the engine oil level goes down rapidly, your motorcycle may have a leak or another serious problem. Have your motorcycle inspected by your dealer.

PGM-FI (Programmed Fuel Injection) Malfunction Indicator Lamp (MIL)

If the indicator comes on while riding, you may have a serious problem with the PGM-FI system. Reduce speed and have your motorcycle inspected by your dealer as soon as possible.

ABS (Anti-lock Brake System) Indicator

If the indicator operates in one of the following ways, you may have a serious problem with the brake system. Reduce your speed and have your motorcycle inspected by your dealer as soon as possible.

- Indicator comes on or starts flashing while riding.
- Indicator does not come on when the ignition switch is in the ON position.
- Indicator does not go off at speeds above 10 km/h (6 mph).

If the ABS indicator stays on, your brakes will continue to work as a conventional system, but without the anti-locking function.

The ABS indicator may flash if you turn the rear wheel while your motorcycle is lifted off the ground. In this case, turn the ignition switch off and then on again. The ABS indicator will go off after your speed reaches 30 km/h (19 mph).

TCS (Traction Control System) Indicator

If the indicator operates in one of the following ways, you may have a serious problem with the TCS (Traction Control System). Reduce your speed and have your motorcycle inspected by your dealer as soon as possible.

- Indicator comes on while riding.
- Indicator does not come on when the ignition switch is turned on.
- Indicator does not go off at speeds above 10 km/h (6 mph).

Even when the TCS indicator is on, your motorcycle will have normal riding ability without TCS function.

- When the indicator comes on while the TCS is in operation, you will have to close the throttle grip completely to regain normal riding ability.

The TCS indicator may come on if you turn the rear wheel while your motorcycle is lifted off the ground. In this case, turn the ignition switch off and on again. The TCS indicator will go off after your speed reaches 10 km/h (6 mph).

Other Warning Indications

Fuel Gauge Failure Indications

If the fuel system has an error, the fuel gauge indicators will be displayed as shown in the illustration.

If this occurs, see your dealer as soon as possible.

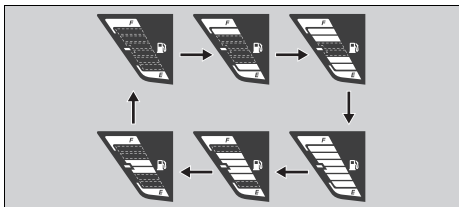
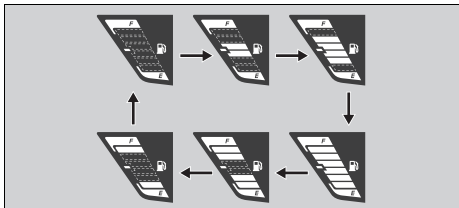

Handle Grip Heater Failure Indication

If the handle grip heater system has an error, the handle grip heater status icon will blink. If the "E1", "E2" or "E3" blinking does not go off, see your dealer as soon as possible.



Handle grip heater status icon

Tyre Puncture

Repairing a puncture or removing a wheel requires special tools and technical expertise. We recommend you have this type of service performed by your dealer. After an emergency repair, always have the tyre inspected/replaced by your dealer.

Emergency Repair Using a Tyre Repair Kit

If your tyre has a minor puncture, you can make an emergency repair using a tubeless tyre repair kit.

Follow the instructions provided with the emergency tyre repair kit.

Riding your motorcycle with a temporary tyre repair is very risky. Do not exceed 50 km/h (30 mph). Have the tyre replaced by your dealer as soon as possible.

WARNING

Riding your motorcycle with a temporary tyre repair can be risky. If the temporary repair fails, you can crash and be seriously injured or killed.

If you must ride with a temporary tyre repair, ride slowly and carefully and do not exceed 50 km/h (30 mph) until the tyre is replaced.

Removing Wheels

Follow these procedures if you need to remove a wheel in order to repair a puncture.

When removing and installing the wheel, be careful not to damage the wheel speed sensor and pulser ring.

Front Wheel

Removal

1. Park your motorcycle on its centre stand on a firm, level surface.
2. Cover both sides of the front wheel and brake caliper with protective tape or cloth.

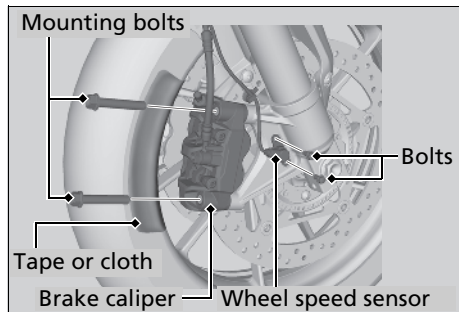

3. Remove the wheel speed sensor by removing the bolts.
4. On the right side, remove the mounting bolts and remove the brake caliper.
 - Support the brake caliper so that it doesn't hang from the brake hose. Do not twist the brake hose.
 - Avoid getting grease, oil, or dirt on the disc or pad surfaces.
 - Do not pull the brake lever while the brake caliper is removed.
 - Take care to prevent the brake caliper from scratching the wheel during removal.
5. On the left side, remove the mounting bolts and remove the brake caliper.

Tyre Puncture ► Removing Wheels

6. Remove the front axle bolt.
7. Loosen the right axle pinch bolt.
8. Support your motorcycle securely and raise the front wheel off the ground using a maintenance stand or a hoist.

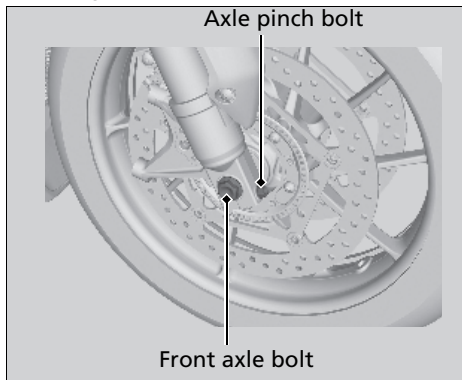

9. Loosen the left axle pinch bolt.
10. On the left side, withdraw the front axle shaft, and remove the side collars and wheel.

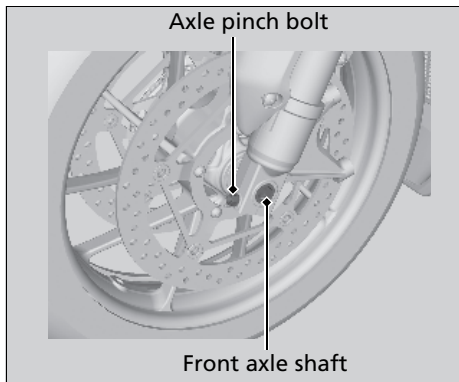

Installation

1. Attach the side collars to the wheel.
2. On the left side, place the wheel between the fork legs and insert the lightly greased front axle shaft to the end, through the left fork leg and wheel hub.
3. Align the end of the front axle shaft with the surface of the fork leg.

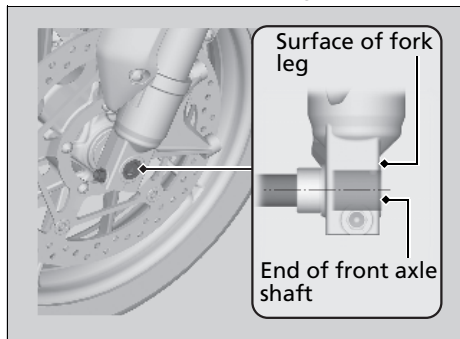

4. Tighten the left axle pinch bolt to hold the axle.
5. Tighten the axle bolt.

Torque: 59 N·m (6.0 kgf·m, 44 lbf·ft).

6. Loosen the left axle pinch bolt.
7. Tighten the right axle pinch bolt.

Torque: 22 N·m (2.2 kgf·m, 16 lbf·ft).

8. Install the right brake caliper and tighten new mounting bolts.

Torque: 45 N·m (4.6 kgf·m, 33 lbf·ft).

9. Install the left brake caliper and tighten new mounting bolts.

Torque: 45 N·m (4.6 kgf·m, 33 lbf·ft).

- Take care to prevent the brake caliper from scratching the wheel during installation.
- Use new mounting bolts when installing the brake caliper.

NOTICE

When installing the brake calipers into position on the fork legs, carefully fit the brake disc between the pads to avoid scratching them.

10. Lower the front wheel on the ground.
11. Apply the brake lever several times. Then, pump the fork several times.
12. Retighten the left axle pinch bolt.

Torque: 22 N·m (2.2 kgf·m, 16 lbf·ft).

13. Raise the front wheel off the ground again, and check that the wheel rotates freely after you release the brake.
14. Install the wheel speed sensor and tighten the bolts, then check the clearance between the wheel speed sensor and the pulser ring.
15. Remove the protective tape or cloth.

If a torque wrench was not used for installation, see your dealer as soon as possible to verify proper assembly. Improper assembly may lead to loss of braking capacity.

I Rear Wheel

Removal

1. Park your motorcycle on its centre stand on a firm, level surface.
2. Loosen the muffler band bolts.
3. Remove the muffler stay bolt, nut and washer.

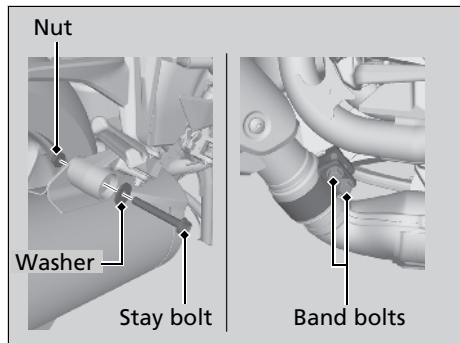

4. Move the muffler outward.
5. Remove the rear wheel nuts, and remove the rear wheel.

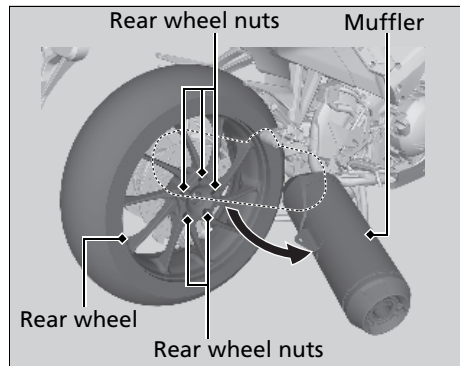

Installation

1. To install the rear wheel, reverse the removal procedure.
2. Tighten the rear wheel nuts equally.

Torque: 108 N·m (11.0 kgf·m, 80 lbf·ft).

3. Hold the muffler mounting bolt and tighten the mounting nut.

Torque: 27 N·m (2.8 kgf·m, 20 lbf·ft).

4. Tighten the muffler band bolts.

Torque: 21 N·m (2.1 kgf·m, 15 lbf·ft).

5. Check that the wheel rotates freely.

If a torque wrench was not used for installation, see your dealer as soon as possible to verify proper assembly. Improper assembly may lead to loss of braking capacity.

Battery Goes Dead

Charge the battery using a motorcycle battery charger.

Remove the battery from the motorcycle before charging.

Do not use an automobile-type battery charger, as these can overheat a motorcycle battery and cause permanent damage.

If the battery does not recover after recharging, contact your dealer.

NOTICE

Jump starting using an automobile battery is not recommended, as this can damage your motorcycle's electrical system.

Burned-out Light Bulb

Follow the procedure below to replace a burned-out light bulb.

Turn the ignition switch to the OFF or LOCK position.

Allow the bulb to cool before replacing it.

Do not use bulbs other than those specified.

Check the replacement bulb for correct operation before riding.

For the light bulb wattage, see "Specifications". ➤ P. 131

Headlight

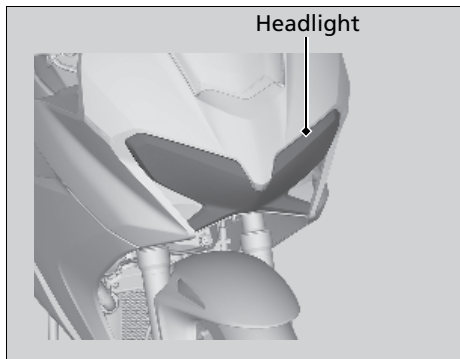

The headlight uses several LEDs.
If there is a LED which is not turned on, see your dealer for this service.

Position Light

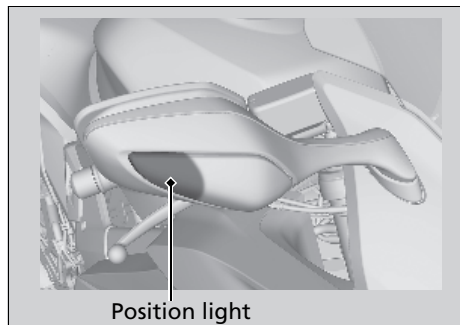

The position lights use several LEDs.
If there is a LED which is not turned on, see your dealer for this service.

Brake/Tail Light

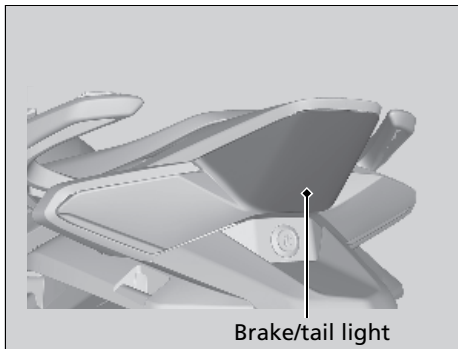

The brake and tail light uses several LEDs. If there is a LED which is not turned on, see your dealer for this service.

Front Turn Signal Bulb

1. Remove the screw.
2. Fold the rearview mirror.

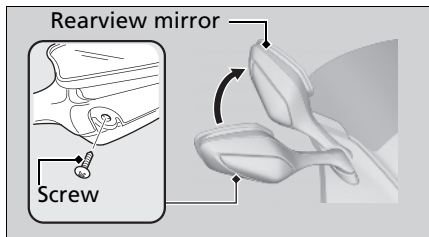

3. Remove the cover from the rearview mirror carefully in the procedure shown in the illustration.

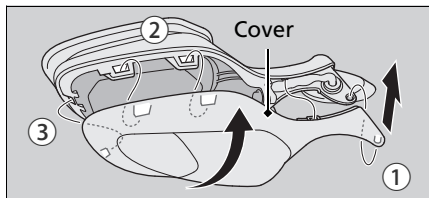

Electrical Trouble ► Burned-out Light Bulb

4. Turn the socket counterclockwise and pull it out.
5. Slightly press the bulb in and turn it counterclockwise.

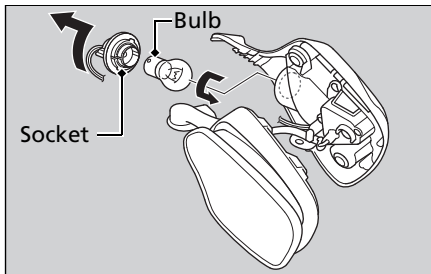

6. Install a new bulb in the reverse order of removal.
► Use only the amber bulb.
7. Reinstall the cover and install the screw and tighten.

Torque: 1.0 N·m (0.1 kgf·m, 0.7 lbf·ft).

I Rear Turn Signal Bulb

1. Remove the rear seat. ► P. 64
2. Remove the bolts.
3. Remove the rear cowl by pulling backward carefully.

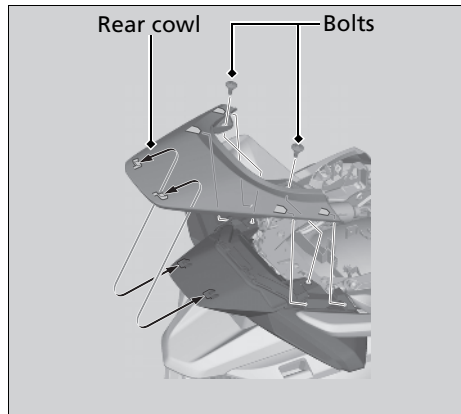

4. Remove the turn signal cover by releasing the tabs carefully.

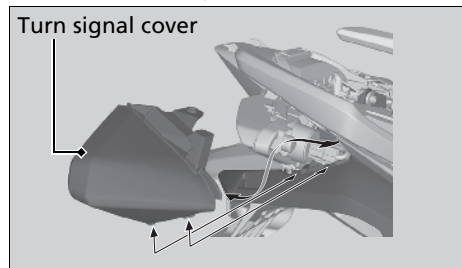

Electrical Trouble ► Burned-out Light Bulb

5. Disconnect the turn signal connector while pressing the tab.
6. Turn the socket counterclockwise and pull it out.
7. Pull the bulb out of the socket without turning it.
8. Install a new bulb and parts in the reverse order of removal.
 - Install the socket with its arrow mark facing up, then turn it clockwise to lock.
 - Use only the amber bulb.

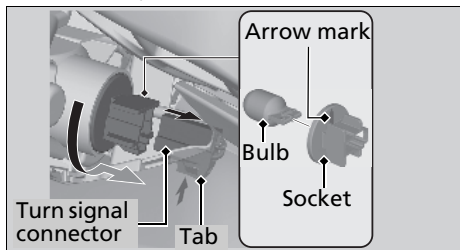

License Plate Light Bulb

1. Remove the screws.
2. Remove the license light cover and license light cover packing.
3. Pull out the bulb without turning.

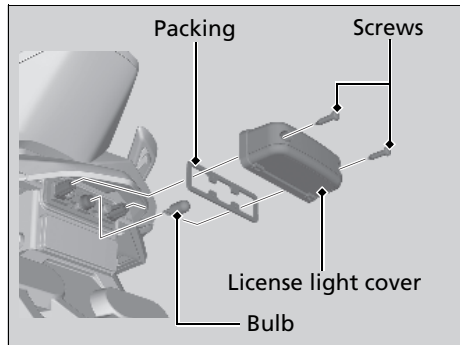

4. Install a new bulb and parts in the reverse order of removal.

Blown Fuse

Before handling fuses, see “Inspecting and Replacing Fuses”. ► P. 55

■ Fuse Box Fuses

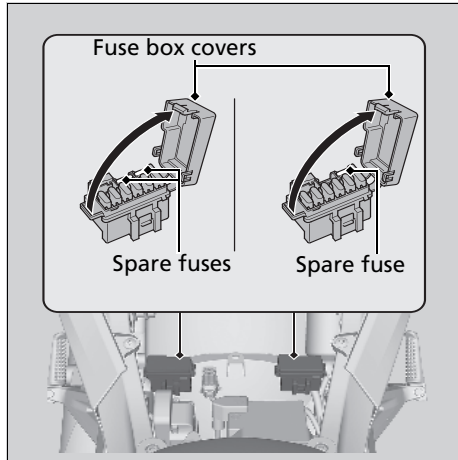

1. Remove the battery cover. ► P. 70
2. Open the fuse box covers.
3. Pull the fuses out with the fuse puller in the tool kit and check for a blown fuse. Always replace a blown fuse with a spare of the same rating.
4. Close the fuse box covers.
5. Reinstall the battery cover.

Main Fuse & FI Fuse

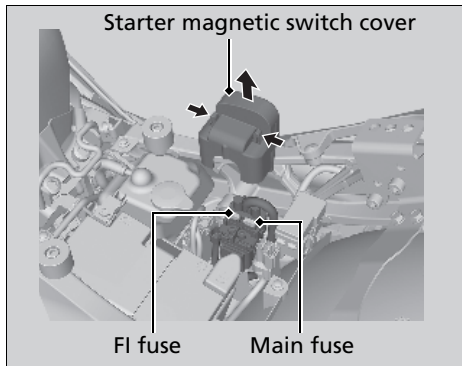

1. Remove the battery cover. ► P. 70
2. Remove the starter magnetic switch cover.

3. Pull the main fuse and FI fuse out with the fuse puller in the tool kit and check for a blown fuse. Always replace a blown fuse with a spare of the same rating.
► Spare fuses are provided in the fuse box.
4. Reinstall parts in the reverse order of removal.

NOTICE

If a fuse fails repeatedly, you likely have an electrical problem. Have your motorcycle inspected by your dealer.

Information

Keys.....	P. 116
Instruments, Controls, & Other Features...P.	117
Fuels Containing Alcohol.....P.	120
Catalytic Converter	P. 121
Caring for Your Motorcycle.....P.	122
Storing Your Motorcycle	P. 125
Transporting Your Motorcycle	P. 126
You & the Environment.....P.	127
Serial Numbers	P. 128

Keys

Ignition key

This motorcycle has two ignition keys and a key tag with a key number and a bar code.

The ignition key contains a special coded chip that is recognized by the immobilizer system (HISS) in order to start the engine. Handle the key carefully to prevent damaging the HISS components.

- Do not bend keys or subject them to undue stress.
- Avoid prolonged exposure to sunlight or high temperatures.
- Do not grind, drill or in any way alter their shape.
- Do not expose to strong magnetic objects.

If you lose all keys and the key tag, the PGM-FI unit/ignition control module must be replaced by your dealer. To avoid this, keep a duplicate

key.

If you lose a key, make another duplicate key immediately.

To make a duplicate key and register it with your HISS system, take the spare key, the key tag, and the motorcycle to your dealer.

► Store the tag in a safe location.

A metal key holder may cause damage to the area surrounding the ignition switch.

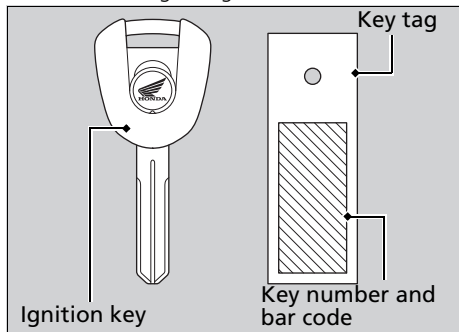

Instruments, Controls, & Other Features

Ignition Switch

The headlight is always on when the ignition switch is ON. Leaving the ignition switch ON with the engine stopped will drain the battery. Do not turn the key while riding.

Engine Stop Switch

Do not use the engine stop switch except in an emergency. Doing so when riding will cause the engine to suddenly turn off, making riding unsafe.

If you stop the engine using the engine stop switch, turn the ignition switch off. Failing to do so will drain the battery.

Odometer

The display locks at 999,999 when the readout exceeds 999,999.

Tripmeter

The tripmeter A, B returns to 0.0 when the readout exceeds 9,999.9.

HISS

The Honda Ignition Security System (HISS) immobilizes the engine's ignition system if an improperly-coded key is used to try and start the engine. When the ignition switch is turned off, the HISS immobilizer system is always alert, even if the HISS indicator is not flashing. If the ignition switch is turned on with the engine stop switch in the  (Run) position, the HISS indicator turns on and goes off after a few seconds to indicate it is OK to start the engine.

❑ HISS Indicator Does Not Turn off P. 94

Instruments, Controls, & Other Features

The HISS indicator starts flashing every 2 seconds for 24 hours after the ignition switch is turned off. You can turn this feature on or off.  P. 31

EC Directive

This immobilizer system complies with R & TTE (Radio and Telecommunications Terminal Equipment and the mutual recognition of their conformity) Directive.



The declaration of conformity to R & TTE Directive is provided to the owner at the time of purchase. The declaration of conformity should be kept at a safe place. When the declaration of conformity is lost or is not provided, contact your dealer.

South Africa only



Singapore only

Complies with
IDA Standards
C080226241

Morocco only

AGREE PAR L'ANRT MAROC

Numéro d'agrément : MR 6164 ANRT 2011
Date d'agrément : 04/04/2011

Document Bag

The owner's manual, registration, and insurance information can be stored in the plastic document bag located under the front seat.

Ignition Cut-off System

A banking (lean angle) sensor automatically stops the engine and fuel pump if the motorcycle falls over. To reset the sensor, you must turn the ignition switch to OFF and back to the ON position before the engine can be restarted.

Fuels Containing Alcohol

Some conventional fuels blended with alcohol are available in some locales to help reduce emissions to meet clean air standards. If you plan to use blended fuel, check that it is unleaded and meets the minimum octane rating requirement.

The following fuel blends can be used in your motorcycle:

- Ethanol (ethyl alcohol) up to 10 % by volume.
 - ▶ Petrol containing ethanol may be marketed under the name Gasohol.

The use of petrol containing more than 10 % ethanol may:

- Damage the painting of the fuel tank.
- Damage the rubber tubes of the fuel line.
- Cause corrosion of the fuel tank.
- Cause poor drivability.

NOTICE

Use of blended fuels containing higher than approved percentages can damage metal, rubber, plastic parts of your fuel system.

If you notice any undesirable operating symptoms or performance problems, try a different brand of petrol.

Catalytic Converter

This motorcycle is equipped with a three-way catalytic converter. The catalytic converter contains precious metals that serve as catalysts in high temperature chemical reactions that convert hydrocarbons (HC), carbon monoxide (CO), and oxides of nitrogen (NOx) in the exhaust gasses into safe compounds.

A defective catalytic converter contributes to air pollution and can impair your engine's performance. A replacement unit must be an original Honda part or equivalent.

Follow these guidelines to protect your motorcycle's catalytic converter.

- Always use unleaded petrol. Leaded petrol will damage the catalytic converter.
- Keep the engine in good running condition.
- Have your motorcycle serviced if your engine is misfiring, backfiring, stalling, or otherwise not running properly, stop riding and turn off the engine.

Caring for Your Motorcycle

Frequent cleaning and polishing is important to ensure the life of your Honda. A clean motorcycle makes it easier to spot potential problems.

In particular, seawater and salts used to prevent ice on roads promote the formation of corrosion. Always wash your motorcycle thoroughly after riding on coastal or treated roads.

Washing

Allow the engine, muffler, brakes, and other high-temperature parts to cool before washing.

1. Rinse your motorcycle thoroughly using a garden hose to remove loose dirt.
2. If necessary, use a sponge or a soft towel with mild cleaner to remove road grime.
 - ▶ Clean the windscreen, headlight lens, panels, and other plastic components with extra care to avoid scratching them.

Avoid directing water into the air cleaner, muffler, and electrical parts.

3. Thoroughly rinse your motorcycle with plenty of clean water and dry with a soft, clean cloth.
4. After the motorcycle dries, lubricate any moving parts.
 - ▶ Make sure that no lubricant spills onto the brakes or tyres. Brake discs or pads contaminated with oil will suffer greatly reduced braking effectiveness and can lead to a crash.
5. Lubricate the drive chain immediately after washing and drying the motorcycle.
6. Apply a coat of wax to prevent corrosion.
 - ▶ Avoid products that contain harsh detergents or chemical solvents. These can damage the metal, paint, and plastic on your motorcycle.Keep the wax clear of the tyres and brakes.

- ▶ If your motorcycle has any mat painted parts, do not apply a coat of wax to the mat painted surface.

■ Washing Precautions

Follow these guidelines when washing:

- Do not use high-pressure washers:
 - ▶ High-pressure water cleaners can damage moving parts and electrical parts, rendering them inoperable.
- Do not direct water at the muffler:
 - ▶ Water in the muffler can prevent starting and causes rust in the muffler.
- Dry the brakes:
 - ▶ Water adversely affects braking effectiveness. After washing, apply the brakes intermittently at low speed to help dry them.
- Do not direct water under the seat:
 - ▶ Water in the underseat compartment can damage your documents and other belongings.

- Do not direct water at the air cleaner:
 - ▶ Water in the air cleaner can prevent the engine from starting.
- Do not direct water near the headlight:
 - ▶ Any condensation inside the headlight should dissipate after a few minutes of running the engine.
- Do not use waxes containing compounds at the mat painted surface:
 - ▶ Using plenty of water, clean the mat painted surface with a soft cloth or sponge. Dry with a soft, clean cloth.
 - ▶ Use neutral detergent to clean mat painted surface.

Aluminium Components

Aluminium will corrode from contact with dirt, mud, or road salt. Clean aluminium parts regularly and follow these guidelines to avoid scratches:

- Do not use stiff brushes, steel wool, or cleaners containing abrasives.
- Avoid riding over or scraping against curbs.

Panels

Follow these guidelines to prevent scratches and blemishes:

- Wash gently using a soft sponge and plenty of water.
- To remove stubborn stains, use diluted detergent and rinse thoroughly with plenty of water.
- Avoid getting petrol, brake fluid, or detergents on the instruments, panels, or headlights.

Windscreen

Using plenty of water, clean the windscreen with a soft cloth or sponge. (Avoid using detergents or any kind of chemical cleaner on the windscreen.) Dry with a soft, clean cloth.

NOTICE

To avoid possible scratching or other damage, use only water and a soft cloth or sponge to clean the windscreen.

For a dirtier windscreen, use a diluted neutral detergent with a sponge and plenty of water. Make sure to wash off all the detergent. (Detergent residue may cause windscreen cracks.)

Replace the windscreen if scratches cannot be removed and they obstruct clear vision.

Take care to keep battery electrolyte, brake fluid, or other chemical solvents off the windscreen and screen garnish. They will damage the plastic.

Exhaust Pipe and Muffler

The exhaust pipe and muffler are stainless steel but may become stained by mud or dust. To remove mud or dust, use a wet sponge and a liquid kitchen abrasive, then rinse well with clean water. Dry with chamois or a soft towel. If necessary, remove heat stains by using a commercially available fine texture compound. Then rinse by the same manner as removing mud or dust.

NOTICE

Even though the exhaust is made of stainless steel, it can become stained. Remove all marks and blemishes as soon as they are noticed.

Storing Your Motorcycle

If you store your motorcycle outdoors, you should consider using a full-body motorcycle cover.

If you won't be riding for an extended period, follow these guidelines:

- Wash your motorcycle and wax all painted surfaces (except mat painted surfaces). Coat chrome pieces with rust-inhibiting oil.
- Lubricate the drive chain. ➤ P. 58
- Place your motorcycle on its centre stand and position a block so that both tyres are off the ground.
- After rain, remove the body cover and allow the motorcycle to dry.
- Remove the battery (➤ P. 71) to prevent discharge. Charge the battery in a shaded, well-ventilated area.
 - ▶ If you leave the battery in place, disconnect the negative ⊖ terminal to prevent discharge.

Transporting Your Motorcycle

After removing your motorcycle from storage, inspect all maintenance items required by the Maintenance Schedule.

Transporting Your Motorcycle

If your motorcycle needs to be transported, it should be carried on a motorcycle trailer or a flatbed truck or trailer that has a loading ramp or lifting platform, and motorcycle tie-down straps. Never try to tow your motorcycle with a wheel or wheels on the ground.

NOTICE

Towing your motorcycle can cause serious damage to the transmission.

You & the Environment

Owning and riding a motorcycle can be enjoyable, but you must do your part to protect the environment.

Choose Sensible Cleaners

Use a biodegradable detergent when you wash your motorcycle. Avoid aerosol spray cleaners that contain chlorofluorocarbons (CFCs) which damage the atmosphere's protective ozone layer.

Recycle Wastes

Put oil and other toxic wastes in approved containers and take them to a recycling centre. Call your local or state office of public works or environmental services to find a recycling centre in your area, and to get instructions on how to dispose of non-recyclable wastes. Do not place used engine oil in the trash, or pour it down a

drain or on the ground. Used oil, petrol, coolant, and cleaning solvents contain poisons that can hurt refuse workers and contaminate drinking water, lakes, rivers, and oceans.

Serial Numbers

The frame and engine serial numbers uniquely identify your motorcycle and are required in order to register your motorcycle. They may also be required when ordering replacement parts. The frame number is stamped on the right side of the steering head.

The engine number is stamped on top of the crankcase.

You should record these numbers and keep them in a safe place.

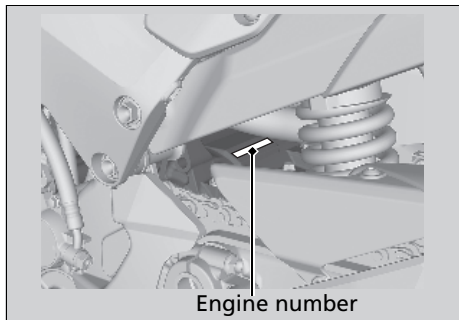
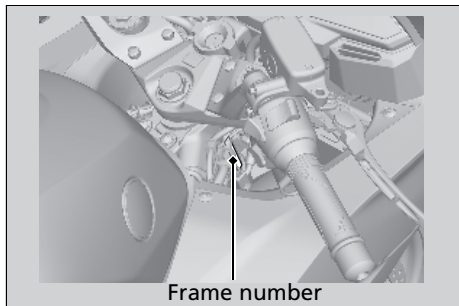

Specifications

■ Main Components

Type	RC79
Overall length	2,140 mm (84.3 in)
Overall width	750 mm (29.5 in)
Overall height	1,210 mm (47.6 in)
Wheelbase	1,460 mm (57.5 in)
Minimum ground clearance	135 mm (5.3 in)
Caster angle	25° 43'
Trail	95 mm (3.7 in)
Curb weight	242 kg (534 lb)
Maximum weight capacity*1	190 kg (419 lb)
Maximum luggage weight*2	18 kg (40 lb)
Passenger capacity	Rider and 1 passenger
Minimum turning radius	3.4 m (11.2 ft)

*1 Including rider, passenger, all luggage, and accessories

*2 Includes the weight of the luggage and added accessories.

Displacement	782 cm ³ (47.7 cu-in)	
Bore x stroke	72.0 x 48.0 mm (2.83 x 1.89 in)	
Compression ratio	11.8 : 1	
Fuel	Unleaded petrol Recommended: 91 RON or higher	
Tank capacity	21.2 litres (5.60 US gal, 4.66 Imp gal)	
Battery	YTZ12S 12V-11Ah (10 HR) / 11.6Ah (20 HR)	
Gear ratios	1st	2.846
	2nd	2.062
	3rd	1.578
	4th	1.291
	5th	1.111
	6th	0.965
Reduction ratios (primary / final)	1.939 / 2.687	

Specifications

■ Service Data

Tyre size	Front	120/70ZR17M/C(58W)
	Rear	180/55ZR17M/C(73W)
Tyre type		Radial, tubeless
Recommended Tyres	Front	DUNLOP D222F K BRIDGESTONE T30F G
	Rear	DUNLOP D222 K BRIDGESTONE T30R G
Tyre air pressure	Front	250 kPa (2.50 kgf/cm ² , 36 psi)
	Rear	290 kPa (2.90 kgf/cm ² , 42 psi)
Minimum tread depth	Front	1.5 mm (0.06 in)
	Rear	2.0 mm (0.08 in)
Spark plugs	(standard)	IMR9D-9H (NGK) or VNH27ZB (DENSO)
Spark plug gap	(non-adjustable)	0.80 to 0.90 mm (0.031 to 0.035 in)
Idle speed	(non-adjustable)	1,200 ± 100 rpm
Recommended engine oil		Honda 4-stroke motorcycle oil API Service Classification SG or higher, excluding oils marked as "Energy Conserving" or "Resource Conserving," SAE 10W-30, JASO T 903 standard MA

Engine oil capacity	After draining	2.9 litres (3.1 US qt, 2.6 Imp qt)
	After draining & engine oil filter change	3.1 litres (3.3 US qt, 2.7 Imp qt)
	After disassembly	3.9 litres (4.1 US qt, 3.4 Imp qt)
Recommended brake (clutch) fluid	Honda DOT 4 Brake Fluid	
Cooling system capacity	2.92 litres (3.09 US qt, 2.57 Imp qt)	
Recommended coolant	Pro Honda HP Coolant	

Recommended drive chain lubricant	Drive chain lubricant designed specifically for O-ring chains. If not available, use SAE 80 or 90 gear oil.	
Drive chain slack	25 to 35 mm (1.0 to 1.4 in)	
Standard drive chain	DID 525HV3 or RK 525ROZ6	
	No. of links	110
Standard sprocket sizes	Engine sprocket	16T
	Rear wheel sprocket	43T

■ Bulbs

Headlight	LED
Brakelight	LED
Tail light	LED
Front turn signal lights	12V-21W x 2
Rear turn signal lights	12V-21W x 2
Position light	LED
License plate light	12V-5W

■ Fuses

Main fuse	30A
Other fuses	30A, 20A, 10A

■ Torque Specifications

Grab rail mounting bolt	27 N·m (2.8 kgf·m, 20 lbf·ft)
Engine oil drain bolt	30 N·m (3.1 kgf·m, 22 lbf·ft)
Oil filter	26 N·m (2.7 kgf·m, 19 lbf·ft)
Bearing holder pinch bolt	88 N·m (9.0 kgf·m, 65 lbf·ft)
Seat adjust plate socket bolts A	22 N·m (2.2 kgf·m, 16 lbf·ft)
Seat adjust set collar socket bolts B	12 N·m (1.2 kgf·m, 9 lbf·ft)
Front wheel axle bolt	59 N·m (6.0 kgf·m, 44 lbf·ft)
Front wheel brake caliper mounting bolts	45 N·m (4.6 kgf·m, 33 lbf·ft)
Front wheel axle pinch bolts	22 N·m (2.2 kgf·m, 16 lbf·ft)
Rear wheel nuts	108 N·m (11.0 kgf·m, 80 lbf·ft)
Muffler band bolts	21 N·m (2.1 kgf·m, 15 lbf·ft)
Muffler mounting nut	27 N·m (2.8 kgf·m, 20 lbf·ft)
Front turn signal cover screws	1.0 N·m (0.1 kgf·m, 0.7 lbf·ft)

A**ABS (Anti-lock Brake System)**

Indicator	35, 97
Accessories	16

B

Battery	54, 71
Battery Cover	70
Brakelight Switch	80

Brakes

Fluid	57, 78
Lever Adjustment	86
Pad Wear	79

Braking	12
----------------------	----

Bulb

Brake/Tail Light	109
Front Turn Signal	109
Headlight	108
License Plate Light	112
Position Light	108
Rear Turn Signal	111

C

Caring for Your Motorcycle	122
Clip	69
Clutch	
Fluid	57, 80
Lever Adjustment	86
Colour Label	53
Coolant	58, 76
Coolant Temperature Gauge	26

D

Digital Clock Adjustment	30
Display Setting	29
Drive Chain	57, 82

E

Electrical Trouble	107
Engine	
Number	128
Oil	56, 72
Oil Filter	74
Overheats	95
Starting	41

Stop Switch.....	37, 41, 117
Stopping.....	117
Environment.....	127
Equipment Compartment	
Helmet Holder.....	44
Owner's Manual	45, 119
Tool Kit.....	45, 63
U-shaped Lock	45
F	
Flooded Engine.....	41
Frame Number	128
Front Brake Lever Adjustment.....	86
Front Seat Height Adjustment.....	91
Fuel	
Gauge.....	21
Mileage Meter	24
Recommended.....	43
Remaining.....	21
Tank Capacity	43
Fuels Containing Alcohol	120
Fuses	55, 113

G

Gear Position Indicator	23
-------------------------------	----

H

Handle Grip Heater	28, 39, 99
Handle Grip Heater Indicator	36, 39
Handle Grip Heater Status Icon.....	21, 39
Hazard Switch.....	37
Headlight Aim	90
Headlight Dimmer Switch.....	36
Helmet Holder	44
High Beam Indicator	34
High Coolant Temperature Indicator	35, 95
HISS Indicator	29, 35, 117
Horn Button.....	37

I

Ignition Cut-off System

Banking Sensor.....	119
Side Stand.....	81
Ignition key.....	116
Ignition Switch	37, 41, 117

Indicators	34
Instruments.....	20
L	
Labels	6
Load Limits.....	17
Loading Guidelines	17
Low fuel Indicator	34
Low Oil Pressure Indicator	34, 96
M	
Maintenance	
Fundamentals.....	52
Importance.....	48
Safety.....	48
Schedule	49
Maximum Weight Limit.....	17
Modifications.....	16
N	
Neutral Indicator	34
O	
Odometer.....	22, 117
Oil	
Engine	56, 72
Overheating.....	95
P	
Parking	14
Parts Location	18
Passing Light Control Switch.....	36
Petrol.....	120
PGM-FI (Programmed Fuel Injection)	
Malfunction Indicator Lamp (MIL)....	34, 96
Protective Apparel.....	11
R	
Recommended	
Coolant	58
Fuel	43
Oil	56
Refuelling.....	43
Removal	
Battery.....	71

Clip.....	69
Front Seat	65
Rear Seat	64
Single Seat Cowl.....	66
Under Cowl	68
Repair Kit.....	100
Riding Precautions	12

S

Safety Precautions	11
Serial Numbers.....	128
Shifting Gears.....	42
Side Stand.....	81
Side Stand Ignition Cut-off System.....	81
Specifications	129
Speedometer.....	21
Start Button.....	37, 41
Starting the Engine.....	41
Steering Lock.....	38
Stopping Engine	117
Storage	
Document Bag.....	45
Equipment	44

Helmet	44
Luggage Tie-down Hook	46
Owner's Manual.....	45, 119
Tool Kit	45
U-shaped Lock.....	45
Storing Your Motorcycle.....	125
Switches	36

T

Tachometer.....	20
TCS (Traction Control System)	15
TCS (Traction Control System) Indicator	36, 98
TCS (Traction Control System) OFF Indicator	35
TCS (Traction Control System) OFF Switch	36
Throttle	85
Tool Kit	45, 63
Transporting Your Motorcycle	126
Tripmeter	22, 117
Troubleshooting.....	93
Turn signal switch	36

Tyres

Air Pressure	60
Puncture.....	100
Replacing	60, 100

W

Warning Indicators On.....	96
Washing Your Motorcycle	122
Weight Limit.....	17

Wheels

Front Removal	101
Rear Removal	105

