

Owner's manual

MONSTER

MONSTER 1100^{EVO} ABS



MONSTER

MONSTER 1100^{EVO} ABS

Hearty welcome among Ducati fans! Please accept our best compliments for choosing a Ducati motorcycle. We are sure that you will use your Ducati for longer journeys as well as short daily trips, but however you use your motorcycle, Ducati Motor Holding S.p.A. wishes you an enjoyable ride. We are continuously working to improve our Technical Assistance service. For this reason, we recommend that you strictly follow the instructions in this manual, especially those regarding the running-in period. This will ensure that your Ducati motorcycle will continue to be a pleasure to ride. For repairs or advice, please contact one of our authorised service centres.

We also provide an information service for all Ducati owners and enthusiasts for any advice and suggestions you might need.

Enjoy the ride!



Note

Ducati Motor Holding S.p.A. cannot accept any liability for errors that may have occurred in the preparation of this manual. All information in this manual is valid at the time of going to print. Ducati Motor Holding S.p.A. reserves the right to make any modifications required due to the ongoing development of their products.

For your safety, as well as to preserve the warranty, reliability and worth of your motorcycle, use original Ducati spare parts only.



Warning

This manual is an integral part of the product and, if ownership is transferred to a third party, must always be passed to the new owner.

E Table of contents

General indications 7

- Warranty 7
- Symbols 7
- Useful road safety information 8
- Riding with a full load 9
- Identification data 10

Instrument panel (Dashboard) 11

- Instrument panel 11
- LCD unit functions 15
- LCD – How to set/display parameters 17
- Total distance covered indicator: "Odometer" 20
- "Speed" indicator 21
- "TRIP" meter 22
- Distance travelled on fuel reserve: "TRIP FUEL" 23
- Clock display indicator 24
- Oil temperature indicator 25
- Service indicator 28
- Battery voltage indicator (BATT) 29

- Engine idle RPM setting (RPM) 31
- Backlighting adjustment 32
- LAP time display function 33
- Stored data display (LAP Memory) 35
- DDA data acquisition 36
- Erase DDA 37
- ABS disabling function 38
- Function for activation/deactivation of DTC (Ducati Traction Control) 39
- Description of the system 39
- Activation of the system 40
- The functions of the system 40
- Routine maintenance 40
- DTC (Ducati Traction Control) setting function 41
- Tips on how to select the sensitivity level 43
- Tips for use on the track 44
- Tips for use on the road 44
- Clock setting function 45
- Instrument panel diagnostics 46
- Headlight "smart" auto-off 51
- Intelligent headlight switch-on 51
- The immobilizer system 52
- Code card 53
- Immobilizer override procedure 54
- Duplicate keys 56
- Service menu - units of measurement (UNIT SET) 57

Controls 59

- Position of motorcycle controls 59
- Ignition switch and steering lock 60

Left-hand handlebar switch 61
Clutch lever 62
Right-hand handlebar switch 63
Throttle twistgrip 64
Front brake lever 64
Rear brake pedal 65
Gear change pedal 65
Adjusting the position of the gearchange and rear brake pedals 66

Main components and devices 68

Position on the vehicle 68
Tank filler plug 69
Seat lock 70
Helmet cable 71
Side stand 72
Front fork adjusters 73
Rear shock absorber adjusters 75

Riding the motorcycle 76

Running-in recommendations 76
Pre-ride checks 77
Starting the engine 79
Moving off 81
Braking 82
Stopping the motorcycle 83
Refuelling 83
Parking 84

Tool kit and accessories 85

Main maintenance operations 86

Changing the air filter 86
Checking brake and clutch fluid levels 86
Checking brake pads for wear 88
Lubricating cables and linkages 89
Throttle cable adjustment 90
Charging and maintenance of the battery during winter storage 90
Removal of the battery 91
Refitting the battery 98
Checking drive chain tension 109
Lubricating the drive chain 110
Changing bulbs 111
Beam setting 112
Tyres 114
Checking the engine oil level 116
Cleaning and replacing the spark plugs 117
General cleaning 118
Storing the motorcycle 119
Important notes 119

Maintenance 120

Programmed maintenance plan: operations to be carried out by the dealer 120
Programmed maintenance plan: operations to be carried out by the customer 123

E	Technical data	124
	Overall dimensions (mm)	124
	Weights	124
	Engine	126
	Timing system	126
	Performance data	127
	Spark plugs	127
	Fuel system	127
	Brakes	128
	Transmission	129
	Frame	130
	Wheels	130
	Tyres	130
	Suspension	130
Exhaust system	131	
Colour schemes	131	
Electric system	131	

Routine maintenance record 136

For United States of America
Version Only 137

Routine Maintenance Record 147

General indications

Warranty

In your own interest, and in order to guarantee product reliability, you are strongly advised to refer to a Ducati Dealer or Authorised Service Centre for servicing that requires any particular technical expertise.

Our highly skilled staff have the tools required to perform any servicing job to the highest professional standards, using only Ducati original spare parts to ensure full interchangeability, smooth running and long life.

All Ducati motorcycles come with a Warranty Booklet. The warranty does not apply to motorcycles used in competitions or in cases where there is evidence of poor maintenance. If any motorcycle part is tampered with, modified, or replaced with parts other than original Ducati spare parts during the warranty period, the warranty is automatically invalidated.

Symbols

Ducati Motor Holding S.p.A. advises you to read this manual carefully in order to familiarise yourself with your motorcycle. If in doubt, please contact a Ducati Dealer or Authorised Service Centre. The information contained herein will prove useful on your trips - and Ducati Motor Holding S.p.A. wishes you smooth, enjoyable riding - and will help you keep the performance of your motorcycle unchanged for a long time. This booklet uses a set of symbols with special meanings:



Warning

Failure to comply with these instructions may put you at risk, and could lead to severe injury or even death.



Important

Risk of damage to the motorcycle and/or its components.



Note

Additional information about the current operation.

References to the RIGHT or LEFT side of the motorcycle assume you are sitting on the seat, facing forward.

Useful road safety information



Warning

Read this section before riding your motorcycle.

Many accidents are the result of the inexperience of the rider. Always make sure you have your licence with you; you need a valid licence that entitles you to ride a motorcycle.

Do not lend your motorcycle to persons who are inexperienced or do not hold a valid licence.

Both rider and pillion passenger must ALWAYS wear a safety helmet.

Do not wear loose clothes or accessories that could become tangled in the controls or limit your field of vision.

Never start or run the engine in enclosed space. Exhaust gases are toxic and may lead to loss of consciousness or even death within a short time.

The rider should keep his/her feet on the footrests when the motorcycle is in motion.

ALWAYS hold the handlebars firmly with both hands so you will be ready for sudden changes in direction or in the road surface. The pillion passenger should ALWAYS hold on to the grabhandles under the seat with both hands.

Ride within the law and observe national and local rules.

Always respect speed limits where these are indicated and ALWAYS adapt your speed to suit the current visibility, road and traffic conditions.

ALWAYS signal your intention to turn or pull to the next lane in good time using the suitable turn signals.

Be sure you are clearly visible and do not ride within the blind spot of vehicles ahead.

Be very careful at road junctions, or when riding in areas near exits from private land or car parks, or on the slip roads to motorways.

ALWAYS turn off the engine when refuelling.

Be extremely careful not to spill fuel on the engine or on the exhaust pipe when refuelling.

Do not smoke when refuelling.

While refuelling, it is possible to inhale noxious fuel vapours. Should any fuel drops be spilled on your skin or clothing, immediately wash with soap and water and change your clothing.

ALWAYS remove the key when you leave your motorcycle unattended.

The engine, exhaust pipes and silencers remain hot for a long time.



Warning

The exhaust system might be hot, even after engine is switched off; take special care not to touch exhaust system with any part of your body and do not park the motorcycle next to inflammable material (wood, leaves etc.).

Park your motorcycle where no one is likely to knock against it, and use the sidestand.

Never park on uneven or soft ground, or your motorcycle may fall over.

Riding with a full load

Your motorcycle is designed for travelling over long distances with a full load in complete safety.

Even weight distribution is critical for maintaining safety standards, and to avoid getting into difficulties when making sudden manoeuvres or riding on bumpy roads.

Information on load capacity

The total weight of the motorcycle in running order including rider, pillion passenger, luggage and additional accessories should not exceed 390 kg.

Arrange your luggage or heavy accessories in the lowest possible position and close to motorcycle centre.

Secure the luggage firmly to the motorcycle structure.

Luggage incorrectly secured may cause the motorcycle to become unstable.

Never attach bulky or heavy objects to the steering head or front mudguard, as this would cause dangerous instability.

Do not insert objects into gaps in the frame, where they could interfere with moving parts.

Make sure the tyres are inflated to the proper pressure indicated at page 114 and that they are in good condition.

Identification data

All Ducati motorcycles have two identification numbers, for the frame (fig. 1) and for the engine (fig. 2).

Frame number

Engine number



Note

These numbers indicate the motorcycle model and should be quoted when ordering spare parts.

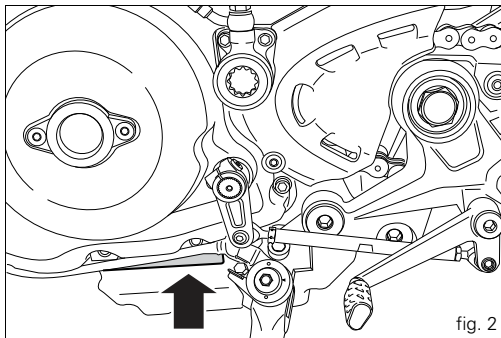
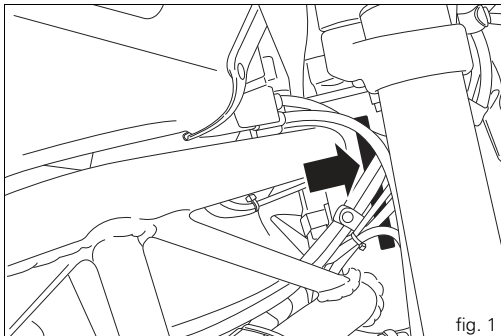

Instrument panel (Dashboard)

Instrument panel

1) LCD, (see page15).

2) REVOLUTION COUNTER (rpm).

Indicates engine revs per minute.

3) NEUTRAL LIGHT N (GREEN).

Illuminates when the gearbox is in neutral.

4) FUEL WARNING LIGHT  (AMBER).

Comes on when fuel is low and there are about 3.5 litres of fuel left in the tank.

5) TURN SIGNAL LIGHTS  (GREEN).

Illuminates and flashes when the turn signal is in operation.

If a turn signal does not work (ex. burnt out bulb) its incorrect operation is signalled by making the light flash twice as fast as in comparison to correct operation.

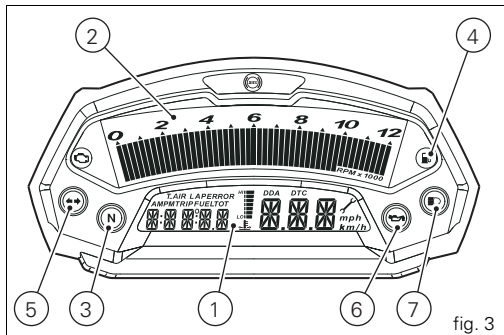

6) ENGINE OIL PRESSURE LIGHT  (RED).

Illuminates when engine oil pressure is too low. It briefly comes on when the ignition is switched to ON and normally goes out a few seconds after engine starts. It may come on briefly if the engine is very hot, but should go out again as engine speed increases.



Important

If this light (6) stays on, stop the engine to avoid serious damage.

7) HIGH BEAM LIGHT  (BLUE).

Illuminates when the high beam headlight is on.

- E 8) "VEHICLE/ENGINE DIAGNOSIS - EOBD" LIGHT (AMBER YELLOW).

It turns on in the case of an engine or motorcycle error; in some cases the engine will be locked.

- 9) LIMITER LIGHT "OVER-REV"/ TRACTION CONTROL LIGHT "DTC" (RED).

	Over rev light
No limiter	Off
1 st threshold - no. RPM before the limiter threshold (*)	On - STEADY
Rev limiter (limiter engaged due to overrevving) (*)	On - Flashing

(*) depending on the model, each calibration of the Engine Control Unit may have a different "setting" for the thresholds that precede the rev limiter and regarding the rev limiter itself.

	DTC intervention lights
No intervention	Off
DTC intervention	On - Steady



Note

If the Over rev function light and the DTC intervention light should both come on at the same time, the instrument panel gives priority to the Over rev function.

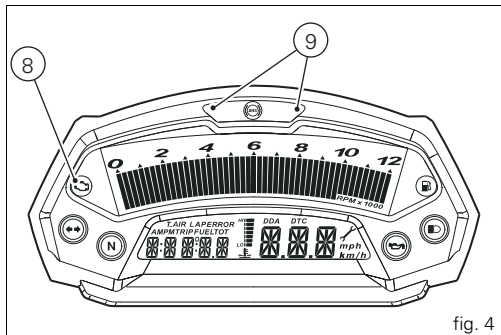

fig. 4

10) ABS LIGHTS (ABS) (AMBER YELLOW).

Engine off / speed below 5 Km/h		
Light off	Light flashing	Light steady
-	ABS disabled with the menu function "DISAB ABS" (**)	ABS enabled but not functioning yet
Engine on / speed below 5 Km/h		
Light off	Light flashing	Light steady
-	ABS disabled with the menu function "DISAB ABS"	ABS enabled but not functioning yet
Engine on / speed above 5 Km/h		
Light off	Light flashing	Light steady
ABS enabled and functioning	ABS disabled with the menu function "DISAB ABS"	ABS disabled and not functioning due to a problem

(**) The ABS should be considered actually disabled only if the light continues to flash after starting the engine.

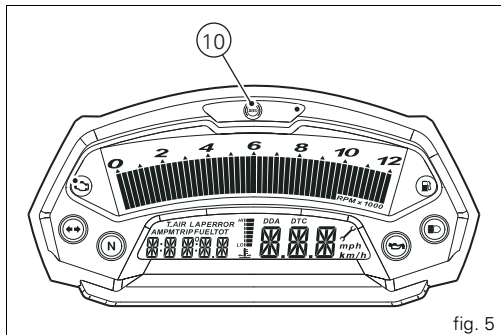

fig. 5

E 11) CONTROL SWITCH.

Button used to display and set instrument panel parameters. It has two positions: A "▲" and B "▼".

12) HIGH-BEAM FLASHER BUTTON FLASH.

The high beam headlight flasher switch is also used for the LAP and USB data acquisition functions.

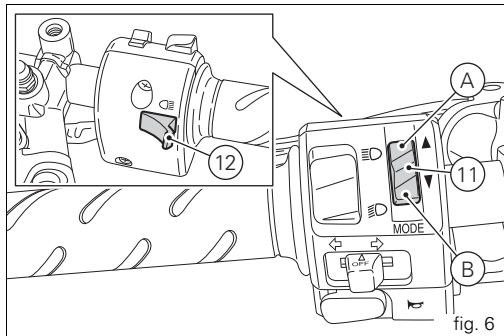

LCD unit functions



Warning

Any adjustments to the instrument panel must only be carried out when the motorcycle is stationary. Never operate the instrument panel controls while riding the motorcycle.

1) SPEEDOMETER.

Gives road speed.

2) ODOMETER.

Shows total distance travelled.

3) TRIP METER.

Indicates the distance travelled since last reset.

4) TRIP FUEL METER.

Shows distance travelled on reserve fuel.

5) CLOCK.

6) AIR TEMPERATURE INDICATOR.

7) LAP TIMER.

8) ENGINE RPM INDICATOR (RPM).

9) LAP TIME (LAP).

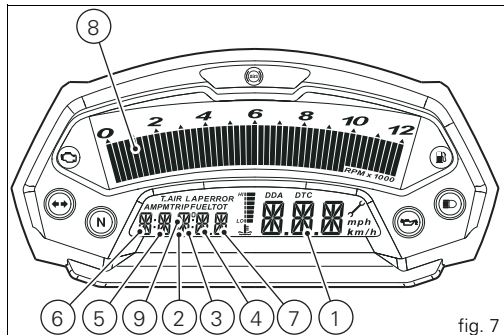

fig. 7

10) MAINTENANCE COUNTER INDICATOR.

This indicator comes on to indicate that the vehicle is due for service.

It stays on until it is reset at a Ducati Dealer or authorised Service Centre as part of the service procedure.

11) LAP FUNCTION.

Indicates that the LAP function has been activated.

12) DDA FUNCTION.

Indicates that the DDA data acquisition has been activated.

Important

The instrument panel incorporates diagnostic functions for the electronic injection/ignition system. Never use the menus reserved for trained personnel for any reason. If this function is accidentally accessed, turn the key to OFF and contact a Ducati Dealer or Authorised Service Centre for the necessary checks.

13) OIL TEMPERATURE INDICATOR.

Important

Stop riding if the temperature reaches the maximum value, otherwise the engine might be damaged.

14) TRACTION CONTROL (DTC).

Indicates activation of the DTC system control unit.

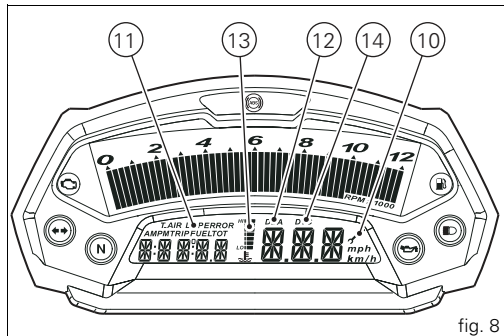

fig. 8

LCD – How to set/display parameters

At key-on (key turned from OFF to ON) the instrument panel activates all the digits of the LCD for 1 second and switches on the indicator lights in sequence.

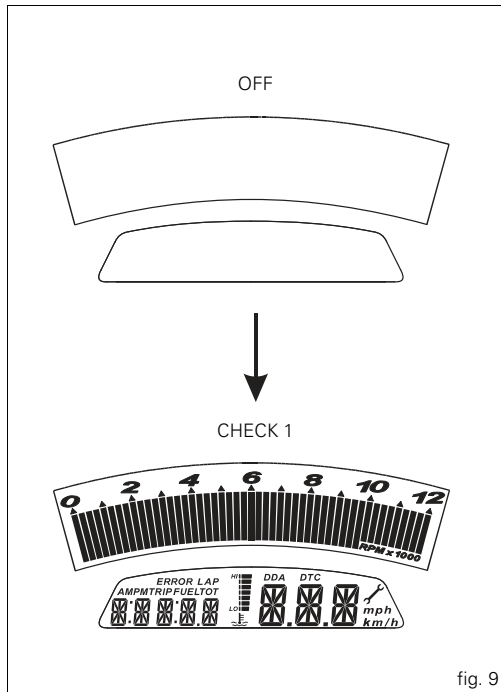
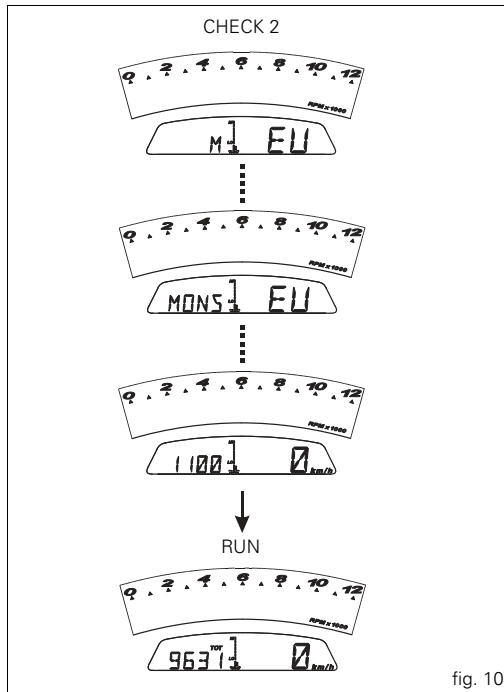

fig. 9

It then reverts to “normal” mode and, in place of the motorcycle speed, shows the model and, for 2 seconds, also the version (EU, UK, USA, CND, FRA, JAP). The model is scrolled on the display once only.



At Key-On, the instrument panel always shows the following information (de-activating any previously activated functions):

- ODOMETER
- SPEED
- RPM BARGRAPH
- ENGINE OIL TEMPERATURE BARGRAPH

With the switch (1, fig. 11) in position B "▼" the Odometer readout (TOT) will cycle through the following functions:

- TRIP
- TRIP FUEL (only if active)
- CLOCK

before returning to TOT (odometer function).

Pressing switch (1, fig. 11) in position A "▲" gives access to the MENU and the following functions are displayed one after another:

- ERROR (only if active)
- BATT
- RPM
- LIGHT SET
- LAP (OFF or ON)
- LAP MEM
- DDA (OFF or ON)
- ERASE DDA
- DISAB ABS
- DDA (OFF or ON)
- DTC SET
- CLOCK SETTING
- CODE (only if active)

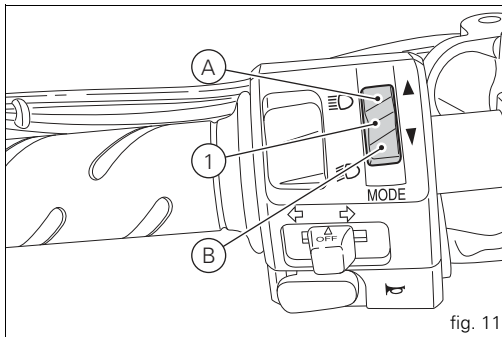

E



Important

This menu is active only if the speed of the motorcycle is less than 20 km/h. If this MENU is open and the speed of the motorcycle exceeds 20 km/h, the instrument panel automatically exits the menu and returns to the initial display. It is possible to exit the menu at any time, however, by pressing switch (1, fig. 11) in position A "▲" for 3 seconds.

Total distance covered indicator: "Odometer"

This function shows the total distance covered by the vehicle.

At Key-On the system automatically enters this function.

The reading is saved permanently and cannot be reset under any circumstances.

If the distance travelled exceeds 99999 km (or 99999 miles), the value "99999" will be displayed permanently.

EU, CND, FRA, JAP versions



UK, USA versions



fig. 12

“Speed” indicator

This function shows vehicle speed.

The dashboard receives the actual speed value (expressed in km/h) from the ECU and displays the value increased by 8%.

Maximum speed displayed is 299 km/h (186 mph).

Over 299 km/h (186 mph) the display will show a series of dashes “- - -” (not flashing).

EU, CND, FRA, JAP versions

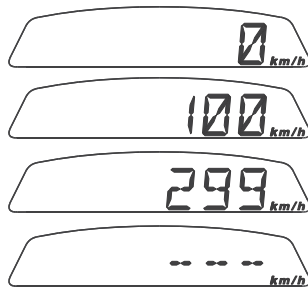

UK, USA versions

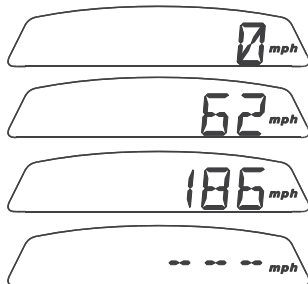

fig. 13

“TRIP” meter

This function shows the distance travelled since the trip meter was last reset.

Holding button (1, fig. 11) pressed in position B “▼” for 3 seconds when this function is displayed resets the trip meter.

If the reading exceeds 999.9, it is reset to zero and the count restarts automatically.

EU, CND, FRA, JAP versions

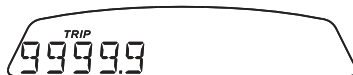
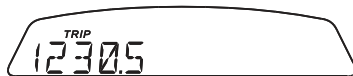

UK, USA versions

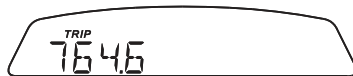

fig. 14

Distance travelled on fuel reserve: "TRIP FUEL"

This function shows the distance travelled on fuel reserve. When the fuel warning light comes on, the TRIP FUEL meter is activated automatically, regardless of the function displayed. If the fuel level remains in reserve, the reading is saved even after Key-Off.

The count stops automatically when the fuel level rises above reserve.

If the reading exceeds 999.9, it is reset and the count restarts automatically.

EU, CND, FRA, JAP versions

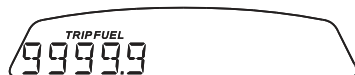
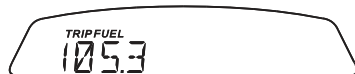

UK, USA versions

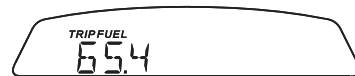

fig. 15

E Clock display indicator

This function shows the time.

Time is always displayed as follows:

AM from 0:00 to 11:59

PM from 12:00 to 11:59

If battery power is suddenly cut off (Batt-OFF), when battery power is restored and upon next Key-On, the clock is reset and restarts operating from "0:00".

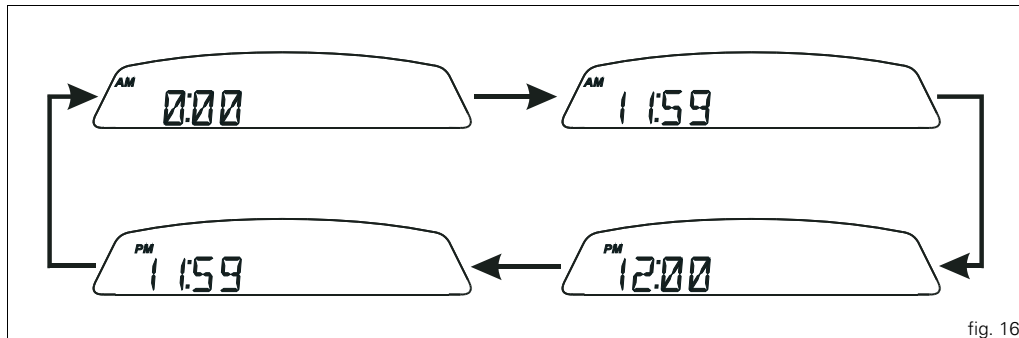

fig. 16

Oil temperature indicator

This function describes the engine oil temperature indicator.

Display indications:

- if the temperature is between -40°C and $+80^{\circ}\text{C}$ the display shows "STATUS 2";
- if the temperature is between $+81^{\circ}\text{C}$ and $+110^{\circ}\text{C}$ the display shows "STATUS 3";
- if the temperature is between $+111^{\circ}\text{C}$ and $+135^{\circ}\text{C}$ the display shows "STATUS 4";

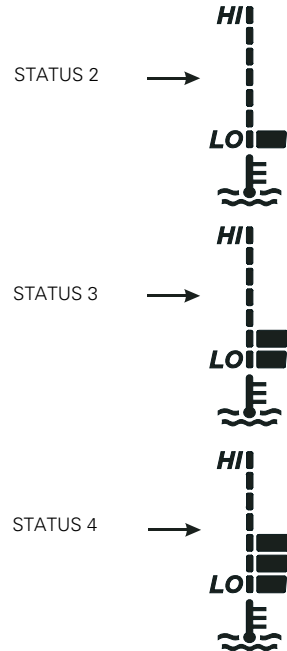

fig. 17

E

- if the temperature is between +136°C and +160°C the display shows "STATUS 5";
- if the temperature is between +161°C and +175°C the display shows "STATUS 6";
- if the temperature is between +176°C and +190°C the display shows "STATUS 7";

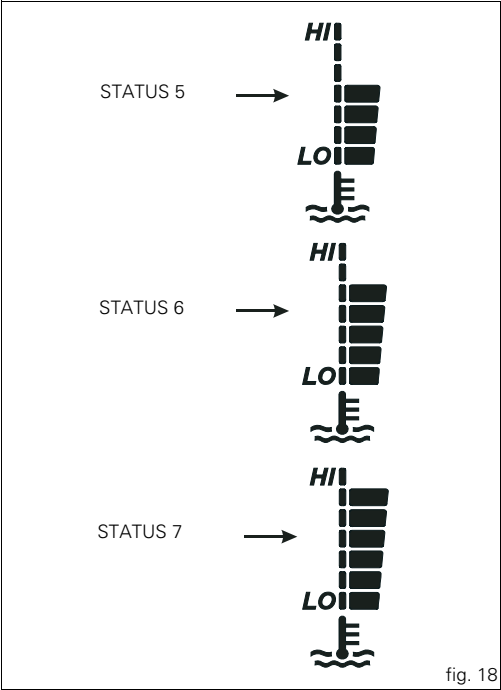

fig. 18

- if the temperature is between +191°C and +200°C the display shows "STATUS 8";
- if the temperature is ≥ 201 °C the display shows "STATUS 9" with the series of flashing marks.
- In case of sensor FAULT, "STATUS 1" is displayed flashing.

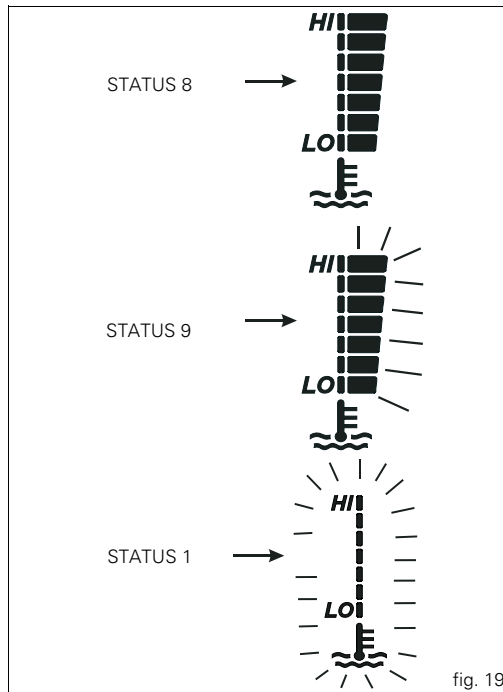

fig. 19

Service indicator

It shows service intervals (service).

Indicator (🔧) comes on to indicate that the vehicle is due for service.

The display shows the service reminder at the following intervals:

after the first 1000 km on the odometer;

every 12000 km on the odometer.

The service indicator will remain on the display until reset.



Warning

This message can only be reset by the Ducati Dealer or Authorised Service Centre that performs the maintenance.

EU, CND, FRA, JAP versions

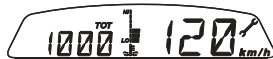
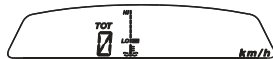

Reset

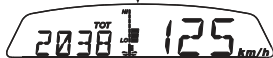

ON (MAINT)

ON (MAINT)

UK, USA versions



Reset



ON (MAINT)

ON (MAINT)

fig. 20

Battery voltage indicator (BATT)

This function describes the battery voltage indicator.

To view this function, access the "BATT" page of the menu.

The battery voltage reading is displayed as follows:

if voltage is between 12.1 and 14.9 Volt, the reading is on steady;

if voltage is between 10.0 and 12.0 Volt or between 15.0 and 16.0 Volt, the reading will be flashing.

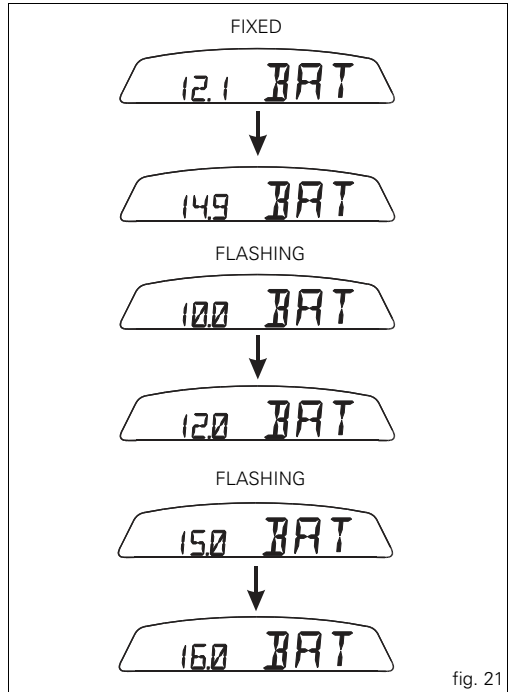

E

if voltage is 9.9 Volt or less, the word "LO" is shown flashing and the Vehicle/Engine Diagnosis light (EOBD) (8, fig. 4) comes on;

if voltage is = 16.1 Volt or higher, the word "HI" is shown flashing and the "Vehicle/Engine Diagnosis- EOBD" light (8, fig. 4) comes on.

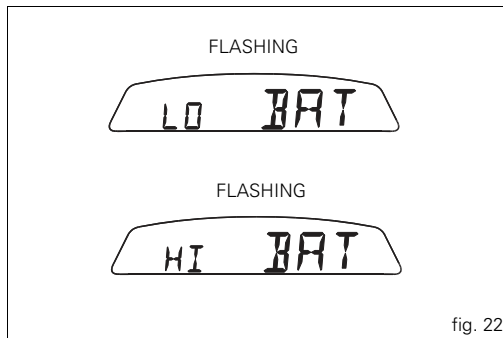

fig. 22

Engine idle RPM setting (RPM)

This function describes engine idle setup.

To display the function, go into the menu and call up the "RPM" page.

In addition to the upper rev counter scale, the display also shows engine rpm numerically so that you can adjust the idle speed more precisely.

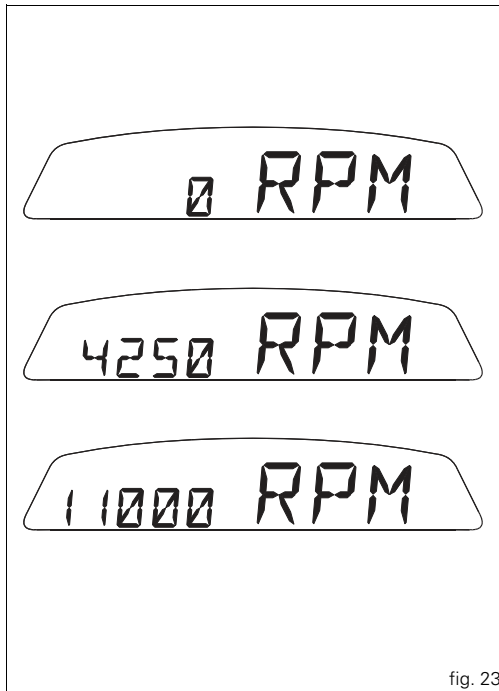

fig. 23

E Backlighting adjustment

This function allows dashboard backlighting power setting. To set the backlighting, access the "LIGHT SET" page of the menu.

Press the switch (1, fig. 11) in position B "▼" for 3 seconds in this page to access the setup mode and the following pages will be displayed in sequence:

- page 1 - "LIGHT MAX" setting:

This page sets backlighting to maximum brightness; press switch (1, fig. 11) in position B "▼" to go to page 2.

- page 2 - "LIGHT MID" setting:

This page reduces the backlighting by approximately 30% relative to maximum brightness; press switch (1, fig. 11) in position B "▼" to go to page 3.

- page 3 - "LIGHT MIN" setting:

This page reduces the backlighting by approximately 70% relative to maximum brightness; press switch (1, fig. 11) in position B "▼" to go to page 1.

If you press the button (1, fig. 11) in position B "▼" for 3 seconds in one these three pages, the instrument panel goes back to the "LIGHT SET" page and stores the selected backlighting setup.

In the event of an interruption of the power supply from the battery, when power is restored at the next Key-On, the backlighting will be set by default to maximum brightness.

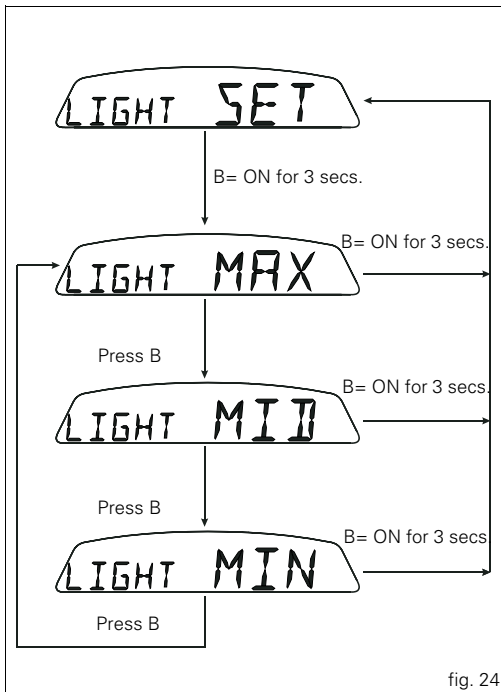

fig. 24

LAP time display function

This function lets you display lap times.

To enable this function, enter the menu and set the "LAP" function to "On" by holding switch (1, fig. 11) pressed in position B "▼" for 3 seconds.

The lap timer is started and stopped using the high-beam flasher button FLASH (12, fig. 6) on the LH switch.

When the LAP function is active, each time you press the FLASH button, the display will show the lap time for 10 seconds, before reverting to normal mode.

You can save a maximum of 30 laps in the memory.

If the memory is full, each time you press the FLASH button, no more lap times can be saved and the display will show the flashing message "FULL" for 3 seconds until the memory is reset.

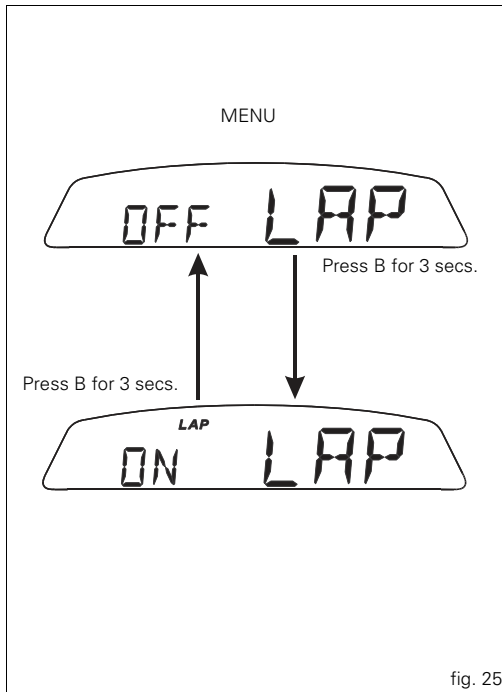

E When the LAP function is set to Off in the menu, the current "lap" is not stored.

If the LAP function is active and the display is suddenly switched off (Key-Off), the LAP function is switched off automatically (even if the timer was ON, the lap in progress is not saved).

If the lap timer is not stopped, it will roll over upon reaching 9 minutes, 59 seconds and 99 hundredths; the lap timer starts counting from 0 (zero) and will keep running until the function is disabled.

If however the LAP function is switched on and the memory has not been cleared, but fewer than 30 laps have been saved (e.g. 18 laps), the display will store any remaining laps until the memory is full (in this case, it will store an additional 12 laps).

This function only displays lap times once; however, lap times are saved for subsequent display in the Lap Memory function.

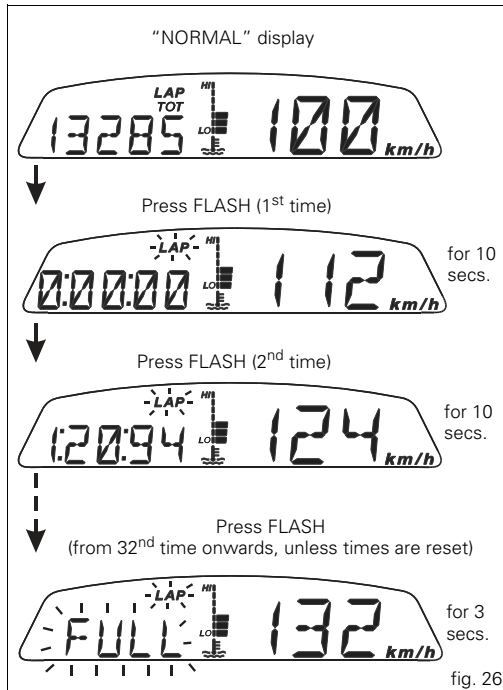

Stored data display (LAP Memory)

It displays data stored using the LAP function: lap number and time.

To display the saved lap times, go into the menu and select the "LAP MEM" page.

Holding switch (1, fig. 11) pressed in position B "▼" for 3 seconds in this menu page accesses the "1st lap" view mode. The display will show the lap number, lap time, MAX speed and the MAX rpm reached for the lap in question.

Press switch (1, fig. 11) in position B "▼" repeatedly to scroll through the 30 laps stored until returning to the 1st lap.

If you press switch (1, fig. 11) in position B "▼" for 3 seconds while the saved times are displayed, the display immediately resets all the saved times; In this case, if the LAP function was active, it is switched off automatically.

The MAX speed saved is the maximum speed indicated on the display in Lap function.

To exit display of the lap times memory press switch (1, fig. 11) in position A "▲".

If no lap times are saved in memory, all 30 lap times will be displayed as "0.00.00".

If the engine trips the rev limiter during a lap, the "REV LIMITER-OVER-REV." (9, fig. 4) light will come on during the display of the lap time.

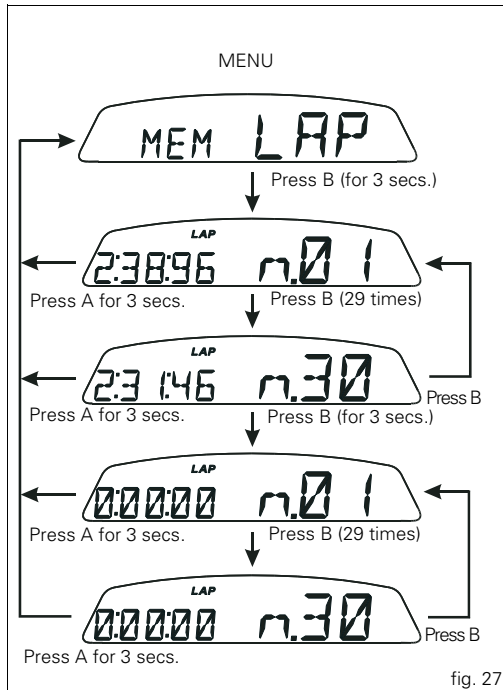

DDA data acquisition

This function serves to activate the DDA (Ducati Data Analyzer): the DDA must be connected to the motorcycle wiring.

To enable this function, enter the menu and set "DDA" data logger to "On" by holding switch (1, fig. 11) pressed in position B "▼" for 3 seconds.

The START/STOP control for the data logger lap separator is the high-beam flash button FLASH (12, fig. 6) on the LH switch.

If the DDA function is active and the display is suddenly switched off (Key-Off), the function is switched off automatically.



Note

Online assistance is available to Ducati Data Analyzer (DDA) owners (<http://dda.prosa.com>). This service will provide anything necessary to correctly use the DDA with your PC: both for the device and the software for analysing the recorded data.



Warning

After use, disconnect the DDA from the main wiring harness.

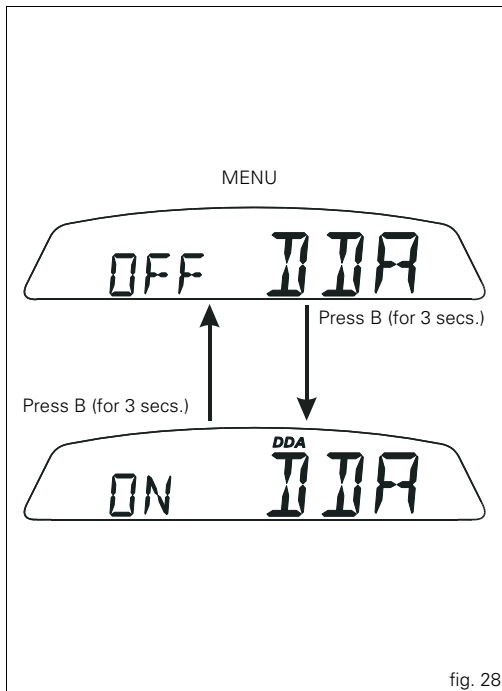

fig. 28

Erase DDA

This function enables you to delete the data saved on the DDA: the DDA must be connected to the motorcycle wiring. To delete the data, enter the menu and select the "Erase DDA" page.

If you press switch (1, fig. 11) in position B "▼" for 3 seconds and the DDA is not acquiring data, the message "WAIT..." is shown on the display for 10 seconds. After 10 seconds, the message "ERASE OK" appears for 3 seconds, to confirm that the data has been deleted.

If switch (1, fig. 11) is pressed in the B "▼" position for 3 seconds while the DDA data logger is acquiring data, the data logger memory is not erased and the display shows message "FAIL" for 3 seconds.

E

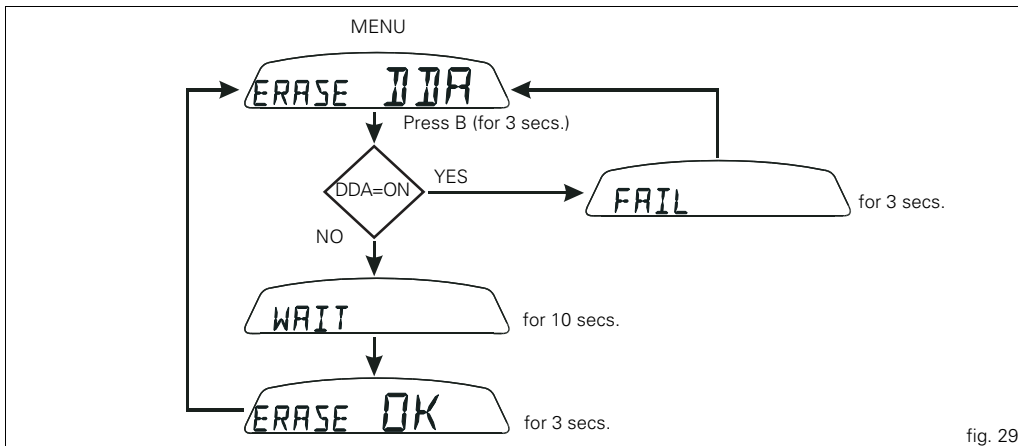

fig. 29

ABS disabling function

This function disables the ABS control unit.



Warning

This operation must be carried out with the vehicle stopped (key ON).

To disable the ABS control unit, access the menu on the "DISAB ABS" page and hold down switch (1, fig. 11) in position B "▼" for 3 seconds.

At the end of the 3 seconds, the flashing ABS light (10, fig. 5) on the instrument panel indicates the disabling.

From this moment, the ABS control unit is disabled; it is automatically restarted at the next Key-Off / Key-On.

At the next Key-On the instrument panel indicates that it is operative by keeping the ABS light (10, fig. 5) off.

If there are problems with the ABS system, the instrument panel indicates its malfunction by keeping the ABS light (10, fig. 5) on steady, the EOBD light (8, fig. 4) on steady and the ABS error in the menu.



Important

This indicator is activated only at a speed above or equal to 10 km/h; at a speed lower than 10 km/h the ABS control unit does not perform the diagnostics.

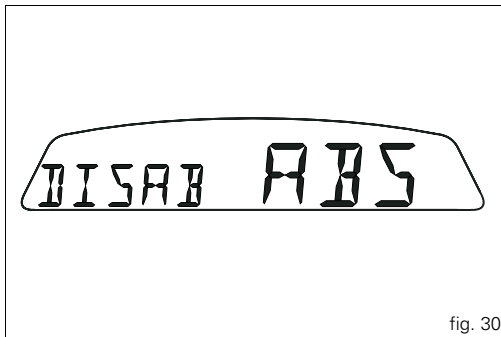

fig. 30

Function for activation/deactivation of DTC (Ducati Traction Control)

It is used to activate the Ducati Traction Control system: DTC.

Description of the system



Warning

DTC is a rider aid that can be used both on the track and the road.

The system is designed to make riding easier and to enhance safety, but in no way relieves the rider of the obligation to drive responsibly and to maintain a high standard of riding in

order to avoid accidents, whether caused by his own errors or those of other road users, through making emergency manoeuvres, in accordance with the prescriptions of the road traffic code.

The rider must always be aware that active safety systems have a preventive function. The active elements help the rider control the motorcycle, making it as easy and safe to ride as possible. The presence of an active safety system should not encourage the rider to ride at speeds beyond the reasonable limits, in accordance with the road conditions, the laws of physics, good riding standards and the requirements of the road traffic code.

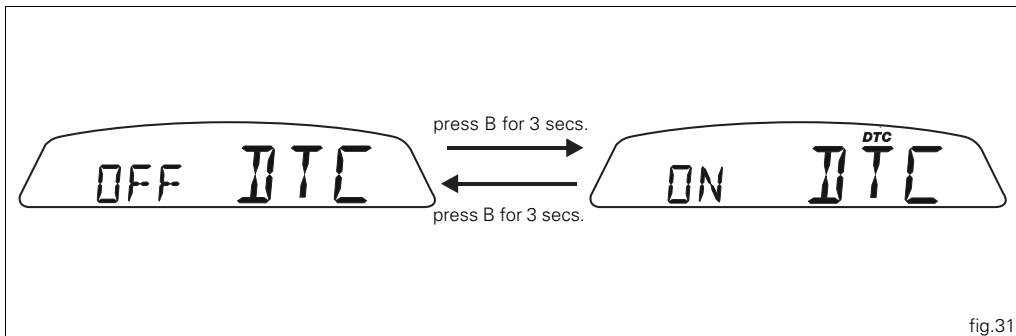

fig.31

Activation of the system

To activate the system, the motorcycle must be stationary and safely parked.

To enable Traction Control, enter the menu and set "DTC" to "On" by pressing switch (1, fig. 11) in position B "▼" for 3 seconds; once the 3 seconds have elapsed, the message "DTC" will appear on the display to indicate activation of the Ducati Traction Control system. When activated, the message "DTC" is visible both on the normal display and also within the menu pages.

The functions of the system



Note

To operate the system, the motorcycle must be stationary and safely parked.

Each time DTC is activated, the Traction Control ECU will set the last sensitivity level stored; the level may then be adjusted using the function "Traction Control Sensitivity Level Setting (DTC SETUP)".

To disable Traction Control, enter the menu and set "DTC" to "OFF" by pressing switch (1, fig. 11) again in position B "▼" for 3 seconds; once the 3 seconds have elapsed, the message "DTC" will disappear from the display, thereby indicating deactivation of the Ducati Traction Control system. If the engine suddenly stops or is switched off (Key-Off) while Traction Control is activated, the function will NOT be disabled but will still be active (DTC On) at the next Key-ON.

If, however, battery power is suddenly cut off (Batt-OFF), when battery power is restored and upon next Key-On, the Traction Control will no longer be activated (DTC OFF).

Routine maintenance

To ensure that system continues to function correctly it is necessary to observe the manufacturer's programmed maintenance schedule.

DTC (Ducati Traction Control) setting function

This function serves to set the sensitivity level for the DTC (Ducati Traction Control).

To set the Traction Control sensitivity level, with the motorcycle stationary, enter the "Setup DTC" menu page. The Traction Control sensitivity level setting (L.1.....L.4) is indicated on the right-hand side of the display; the sensitivity levels range from "1" to "4"; the higher the number, the greater the intervention of the Traction Control system (see following paragraph).

Within this menu page, press switch (1, fig. 11) in position B "▼" for 3 seconds to access the level setting function.

page 1: the display will show "Setup LEV. 1".

If you wish to set this level, press switch (1, fig. 11) in position B "▼" for 3 seconds; the instrument panel will automatically quit this page and return to the initial display, with the level setting indicated on the right.

If instead you wish to set the next highest level, press switch (1, fig. 11) in position B "▼".

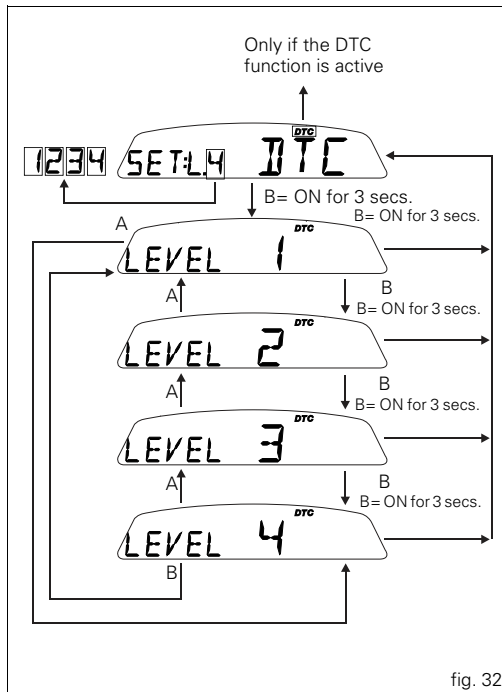

fig. 32

E page 2: the display will show "Setup LEV. 2".

If you wish to set this level, press switch (1, fig. 11) in position B "▼" for 3 seconds; the instrument panel will automatically quit this page and return to the initial display, with the level setting indicated on the right.

If instead you wish to set the next highest level, press switch (1, fig. 11) in position B "▼". While if you wish to go back to the previous level, press switch (1, fig. 11) in position A "▲".

page 3: the display will show "Setup LEV. 3".

If you wish to set this level, press switch (1, fig. 11) in position B "▼" for 3 seconds; the instrument panel will automatically quit this page and return to the initial display, with the level setting indicated on the right.

If instead you wish to set the next highest level, press switch (1, fig. 11) in position B "▼". While if you wish to go back to the previous level, press switch (1, fig. 11) in position A "▲".

page 4: the display will show "Setup LEV. 4".

If you wish to set this level, press switch (1, fig. 11) in position B "▼" for 3 seconds; the instrument panel will automatically quit this page and return to the initial display, with the level setting indicated on the right.

If instead you wish to set the next highest level, press switch (1, fig. 11) in position B "▼". While if you wish to go back to the previous level, press switch (1, fig. 11) in position A "▲". The level setting will remain in memory even after Key-Off.

If, however, battery power is suddenly cut off (Batt-OFF), when battery power is restored and upon next Key-On, the Traction Control will no longer be activated (DTC OFF), and the setting will always be on L4.

Tips on how to select the sensitivity level



Warning

The 4 DTC level settings have been calibrated using the same tyres as those originally supplied with your motorcycle (same make, model and size).

The use of tyres of different size to the original tyres may alter the operating characteristics of the system.

In the case of minor differences, such as for example, tyres of a different make and/or model than the OE ones, but with the same size (rear = 180/55-17; front = 120/70-17), it may be sufficient to simply select the most suitable level setting from those available to restore optimal system operation.

If tyres of a different size class are used or if the tyre size differs significantly from the original tyres, it may be that the system operation is affected so much that none of the 4 available level settings will give satisfactory results.

In this case it is advisable to deactivate the traction control system.

If level 4 is selected, the DTC control unit will kick in at the slightest hint that the rear wheel is starting to spin.

Between level 4 and level 1 there are 2 other intermediate levels. The level of DTC intervention decreases in equal steps from level 4 to 1.

When level 1 or 2 is selected the DTC control unit will allow the rear wheel to spin and also slide sideways on exiting a corner; we recommend that this setting is only used by very experienced riders.

The choice of the correct level depends on 3 main variables:

- 1) The grip (type of tyre, amount of tyre wear, the road/ track surface, weather conditions, etc.)
- 2) The characteristics of the path/circuit (bends all taken at similar speeds or at very different speeds)
- 3) The riding style (whether the rider has a "smooth" or a "rough" style)

The relation of the DTC intervention level to grip conditions:
The choice of level setting depends greatly on the grip conditions of the track/circuit (see below, tips for use on the track and on the road).

The relation of the DTC intervention level to the circuit characteristics:

If all the corners on the track/circuit can be taken at a similar speed, it will be easier to find an intervention level that is satisfactory for every bend; on the other hand, if the track has, for example, one corner that is much slower than all the others, it will necessary to find a compromise level (on the slow corner the DTC will tend to control more than on the faster corners).

The relation of the DTC intervention level to riding style:

The DTC will tend to kick in more with a "smooth" riding style, where the bike is leaned over further, rather than with a "rough" style, where the bike is straightened up as quickly as possible when exiting a turn.

Tips for use on the track

We recommend level 4 be used for a couple of full laps (to allow the tyres to warm up) in order to get used to the system. Then try levels 3, 2, 1, etc., in succession until you identify the DTC sensitivity level that suits you best (always try each level for at least two laps to allow the tyres to warm up).

Once you have found a satisfactory setting for all the corners except one or two slow ones, where the system tends to kick in and control too much, you can try to modify your riding style slightly to a more “rough” approach to cornering i.e. straighten up more rapidly on exiting the corner, instead of immediately trying a different level setting.

Tips for use on the road

Activate the DTC, select level 4 and ride the motorcycle in your usual style; if the level of DTC sensitivity seems excessive, try reducing the setting to level 3, 2, 1, etc., until you find the level that suits you best.

If changes occur in the grip conditions and/or circuit characteristics and/or your riding style, and the level setting is no longer suitable, switch to the next level up or down and proceed to determine the best setting (e.g. if with level 3 the DTC intervention seems excessive, switch to level 2; alternatively, if on level 3 you cannot perceive any DTC intervention, switch to level 4).

Clock setting function

This function is used to set the clock time.

To set the clock, access the "SET" page in the menu.

Setting the time.

Holding switch (1, fig. 11) pressed in position B "▼" for 3 seconds in this menu page gives access to the setup mode.

On entering this function, the message "AM" flashes on the display; if you press switch (1, fig. 11) in position B "▼" the message "PM" flashes; if you press switch (1, fig. 11) in position B "▼" the mode will go back to previous setting (if it is 00:00, when toggling from "AM" to "PM", 12:00 will be displayed).

Pressing switch (1, fig. 11) in position A "▲" gives access to the hour setting mode; hours start to flash. Each time you press the button in position B "▼", the digit will increase by one hour. If the switch is held pressed in position B "▼" the number increases cyclically in steps of one hour every second (when the switch is held depressed, the hours do not flash).

Pressing switch (1, fig. 11) in position A "▲" gives access to the minute setting mode; minutes start to flash. Each time you press the button in position B "▼", the digit will increase by one minute. If you hold the switch down in position B "▼", the count increases cyclically in steps of 1 minute every second. If the button is held depressed in position B "▼" for over 5 seconds, minutes will increase by 1 minute every 100ms (while the button is held depressed in position B "▼", seconds will not flash).

Pressing the button in position A "▲", exits setup mode and the new time is displayed.

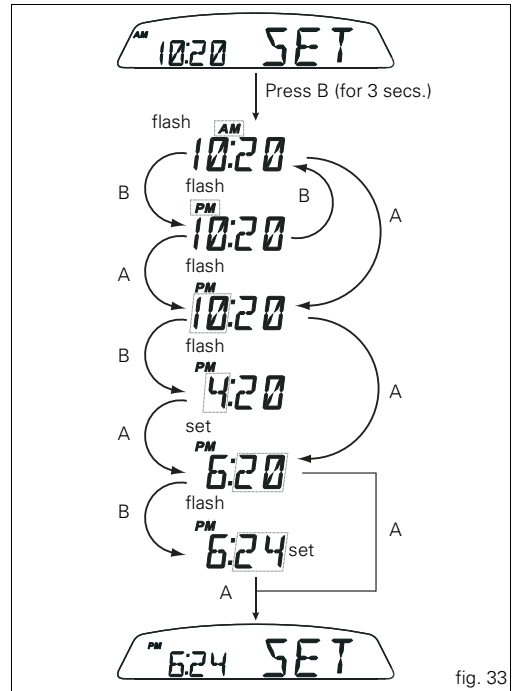

fig. 33

Instrument panel diagnostics

Important

The instrument runs the system diagnostics correctly 60 seconds after the last Key-Off.

This function allows you to display and identify malfunctions of the motorcycle and, where possible, renew components identified as faulty.

To view this function, access the "Error" page of the menu.

This menu is only active when at least one error is present, otherwise the page will NOT appear.







If more errors are present, they are displayed one by one every 3 seconds.













In any case, a more detailed diagnosis can be obtained using the Ducati Diagnostic System.

























Warning



When an error is displayed, always contact a Ducati Dealer or authorised Service Center.

WARNING LIGHT	ERROR MESSAGE	ERROR
	TPS	01 Throttle position sensor short circuit Volt DC or AC
	TPS	01 Throttle position sensor short circuit GND
	PRESS	02 Throttle position sensor short circuit Volt DC
	PRESS	02 Throttle position sensor short circuit GND or AC
	OIL	03 Oil NTC sensor short circuit Volt DC or AC
	OIL	03 Oil NTC sensor short circuit GND
	T AIR	04 Air temperature sensor short circuit GND or AC

WARNING LIGHT	ERROR MESSAGE	ERROR	
	T AIR	04	Air temperature sensor short circuit Volt DC
	BATT	05	LOW battery voltage level
	BATT	05	HIGH battery voltage level
	LAMB	06	Lambda sensor (rim runout)
	LAMB	06	Lambda sensor heater short circuit Volt DC
	LAMB	06	Lambda sensor heater short circuit GND or AC
	FUEL	07	Fuel reserve NTC sensor short circuit Volt DC or AC
	FUEL	07	Fuel reserve NTC sensor short circuit GND
	DTC	08	Traction Control
	COIL	09	Vertical coil (2) short circuit Volt DC
	COIL	09	Vertical coil (2) short circuit Volt DC or AC
	COIL	09	Horizontal coil (1) short circuit Volt DC

WARNING LIGHT	ERROR MESSAGE	ERROR	
	COIL	09	Horizontal coil (1) short circuit Volt DC or AC
	INJE	10	Vertical injector (2) short circuit Volt DC
	INJE	10	Vertical injector (2) short circuit Volt DC or AC
	INJE	10	Horizontal injector (1) short circuit Volt DC
	INJE	10	Horizontal injector (1) short circuit Volt DC or AC
	FAN	11	AC Fan Relay
	START	12	Solenoid starter short circuit Volt DC
	START	12	Solenoid starter short circuit GND or AC
	R INJ	13	Injection relay AC
	STEPP	14	Stepper motor AC
	STEPP	14	Stepper motor short circuit Volt DC

WARNING LIGHT	ERROR MESSAGE	ERROR	
	STEPP	14	Stepper motor short circuit GND
	EXVL	15	Seek Fail or Position Error Exhaust Valve Motor
	EXVL	15	Position sensor short circuit GND or AC
	EXVL	15	Position sensor short circuit Volt DC
	EXVL	15	Starter motor damaged / not functioning
	ECU	16	ECU (generic error)
	PKUP	17	Pickup sensor
	SPEED	18	Speed sensor
	IMMO	19	Immobilizer (key missing)
	IMMO	19	Immobilizer (antenna disconnected)
	IMMO	19	Immobilizer (key not recognised)

WARNING LIGHT	ERROR MESSAGE	ERROR	
	CAN	20	CAN line
	LIGHT	21	Light relay
	ABS	22	ABS system error

Headlight “smart” auto-off

This function helps reduce battery use by automatically switching off the headlight. The device is triggered in 3 cases:

- 1) When the key is turned from OFF to ON and the engine is not started within 60 seconds, the headlight is turned off and will be turned back on next time you start the engine.
- in case 2, after the vehicle has been running with the headlights on and the engine is stopped using the RUN-STOP button on the RH switch.
In this case, 60 seconds after stopping the engine, the headlight is turned off and will be turned back on next time you start the engine.
- 3) While starting up the engine, the headlight is turned off and back on as soon as the engine is started.

Intelligent headlight switch-on

This function allows programmed activation of the headlight even with the motorcycle off (Key-Off).

The instrument panel stays active for 60 seconds soon after Key-Off, and the headlight can be switched on by pressing switch (1, fig. 11) in position A “▲” or B “▼”.

During these 60 seconds, each time switch (1, fig. 11) is pressed in position A “▲” or B “▼”, the instrument panel will activate the headlight for 30 seconds; each press of the switch will add to the headlight activation time, up to a maximum of 6 presses (equivalent to a maximum activation time of 180 seconds).

After the first time you press switch (1, fig. 11) in position A “▲” or B “▼”, the period of 30 seconds starts, thus switching on the headlight. Further switch-on time can be added only if you press the switch again within these 30 seconds. If the 30 seconds have elapsed, no further multiples of 30 seconds can be added, and the instrument panel will switch off the headlight.

To reset this function, you must perform at least one Key-On/Key-Off.

If the battery power is interrupted at any time while this function is active, when power is restored, the instrument panel will de-activate the function (the instrument panel does not remain active for 60 seconds).

The immobilizer system

For additional anti-theft protection, the motorcycle is equipped with an IMMOBILIZER, an electronic system that locks the engine automatically whenever the ignition switch is turned off.

The grip of each ignition key contains an electronic device that modulates the output signal from a special antenna in the switch when the ignition is switched On. The modulated signal represents the "password" (which is changed at each start-up) by which the ECU recognizes the ignition key. The ECU will only allow the engine to start if it recognises this password.

Keys (fig. 34)

The owner receives a set of keys, comprising:

- 2 (BLACK) keys B

These contain the "code" of the immobilizer system.

Note

Your Ducati dealer may ask you to produce your Code Card in order to carry out certain servicing operations.

The black keys (B) are the keys for normal use, and are used to:

- start up the engine
- open the fuel tank filler plug
- open the seat lock.

Note

The two keys have a small tag (1) attached, which shows their identification number.

Warning

Keep the keys separately and use only one of the black keys to start the motorcycle.

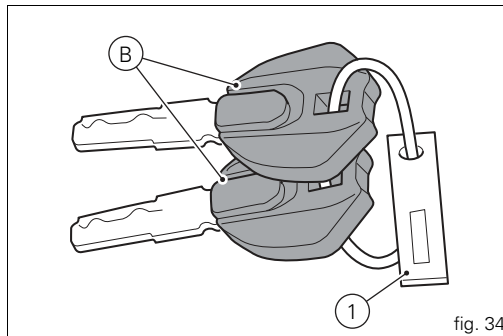

fig. 34

Code card

The CODE CARD (fig. 35) supplied with the keys reports an electronic code (A, fig. 36) to start the engine in the event it fails to start after KEY-ON because the immobilizer system inhibited the ignition.



Warning

Keep the CODE CARD in a safe place. However, it is advisable to keep the electronic code printed on the CODE CARD handy when you ride your motorcycle, in case it is necessary to enable the engine through the procedure described below. This procedure lets you disable the "engine block" function - indicated by the amber yellow "Vehicle/ engine Diagnosis EOBD" light (8, fig. 4) coming on - in the event of problems with the immobilizer system. This operation is only possible if the electronic code indicated on the code card is known.



Warning

Your dealer will ask you to produce the Code Card in order to re-program or replace a key.

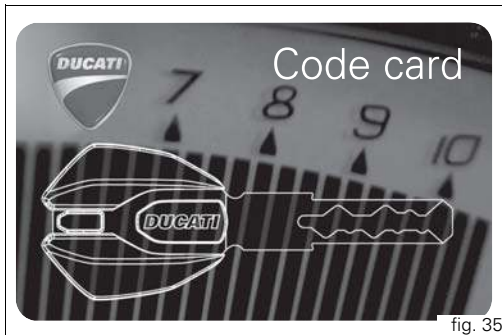

fig. 35

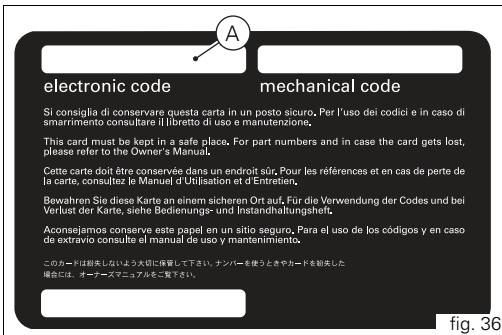

fig. 36

Immobilizer override procedure

In the event of an "Immobilizer BLOCK", you will have to perform the "Immobilizer override procedure" from the instrument panel; enter the corresponding function as described below:
Enter the menu and go to page "COD.".



Note

This menu should be active only if there is at least one immobilizer error.

With this page selected, the initial code is always displayed as "00000". If you hold pressed switch (1, fig. 11) in position B "▼" for 3 seconds, you will access the procedure for entering the electronic code given on the Code Card.

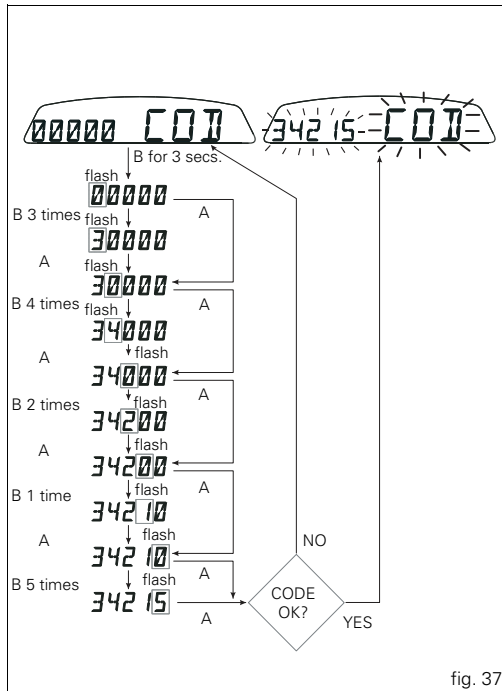

fig. 37

Entering the code:

on entering this function, the first digit on the left starts flashing.

Switch (1, fig. 11):

each time you press the switch in position B "▼", the number increases cyclically in steps of one digit every second;

if you press the switch in position A "▲", you can set the second digit, which will start flashing. Each time you press the switch in position B "▼", the number increases cyclically in steps of one digit every second;

if you press the switch in position A "▲", you can set the third digit, which will start flashing. Each time you press the switch in position B "▼", the number increases cyclically in steps of one digit every second;

if you press the switch in position A "▲", you can set the fourth digit, which will start flashing. Each time you press the switch in position B "▼", the number increases cyclically in steps of one digit every second;

if you press the switch in position A "▲", you can set the fifth digit, which will start flashing. Each time you press the switch in position B "▼", the number increases cyclically in steps of one digit every second;

press in position A "▲" to confirm the code.

If the code has been entered correctly, the message CODE and the code itself will flash simultaneously for 4 seconds. The "Vehicle/engine diagnosis EOBD" light (8, fig. 4) will turn off; The instrument panel then automatically exits the menu, thus allowing "temporary" starting of the motorcycle. If the error persists, at the next key-on, the instrument panel will return to an error state and immobilize the engine. If the code is not entered correctly, the instrument panel returns automatically to the "COD" menu, displaying code "00000".

Operation

When the ignition key is turned from ON to OFF, the immobilizer system activates the engine lock. When the ignition key is turned from OFF to ON to start the engine:

1) if the code is recognised, the protection system releases the engine lock. Press the START button (2, fig. 43), to start the engine;

2) if the "Vehicle/Engine Diagnosis - EOBD" light (8, fig. 4) comes on and the page with the "Error" message is displayed when you press switch (1, fig. 11) in position B "▼" it means that the code was not recognised. In this case, turn the ignition key back to OFF and then to ON again. If the engine still does not start, try again with the other black key. If the engine still does not start, contact the DUCATI Service network.



Warning

Sharp knocks can damage the electronic components inside the key.

Always use the same key throughout the procedure. Using different keys could prevent the system from recognising the code in the key.

Duplicate keys

If you need additional keys, contact your DUCATI Service Centre with all the keys you have in your possession and your CODE CARD.

The Ducati Service Centre will program all the new keys as well as any keys you already have.

You may be asked to provide proof that you are the legitimate owner of the motorcycle.

The codes for any keys not present during the memory programming procedure are cancelled, to ensure that any keys that may have been lost can no longer be used to start the engine.



Note

If you sell your motorcycle, it is essential to transfer all keys and the CODE CARD to the new owner.

Service menu - units of measurement (UNIT SET)

This function allows you to set the units of measurement for the values displayed on the instrument panel.

To enter the service menu, press and hold button (1, fig. 11) in position A "▲" while turning the ignition switch from "Off" to "On".



Note

Within this menu, any other function is disabled and engine starting is disabled as well.

The first function displayed is "Immobilizer Reprogramming" (00000 PRO), press button (1, fig. 11) in position A "▲" to display the other function of the service menu "UNIT SET". Now press button (1, fig. 11) in position B "▼" for 3 seconds. Every time you press button (1, fig. 11) in position B "▼", the instrument panel toggles through the following flashing values:

UNIT OF MEASUREMENT			
Country standard	Speed	Air temperature	Odometer/ trip meters
EU	Km/h	°C	Km
EN	Mph	°C	miles
USA	Mph	°F	miles
CND	Km/h	°C	Km
FRA	Km/h	°C	Km
JAP	Km/h	°C	Km
ECU Id.	The instrument panel sets units of measurement according to ECU information		

Press button (1, fig. 11) in position B "▼" for 3 seconds to store the displayed settings, the message "MEM" confirms storage.

Upon the following Key-On the instrument panel will be set to the new settings.

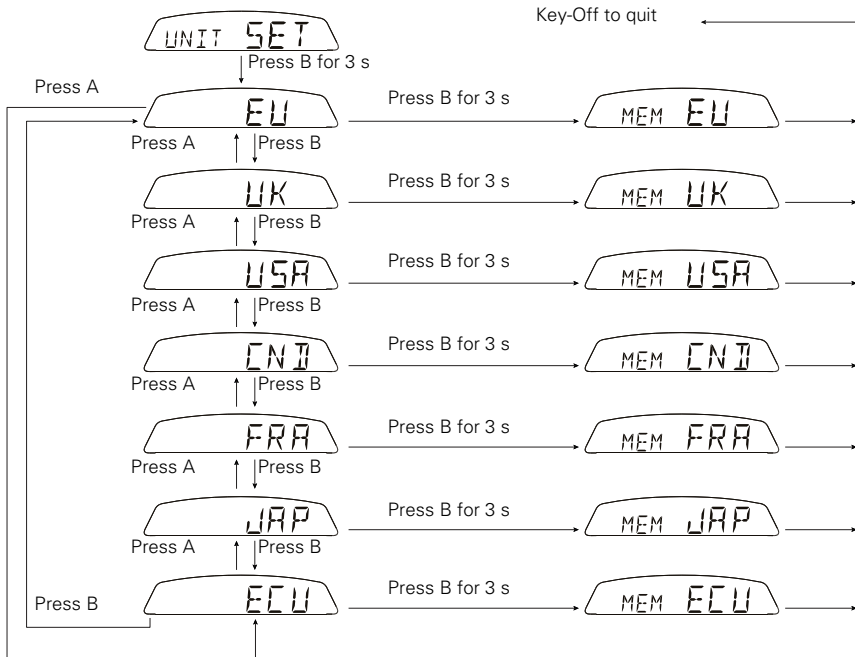

fig. 38

Controls



Warning

This section shows the position and function of the controls used to drive the motorcycle. Be sure to read this information carefully before you use the controls.

Position of motorcycle controls

- 1) Instrument panel.
- 2) Key-operated ignition switch and steering lock.
- 3) Left-hand handlebar switch.
- 4) Clutch lever.
- 5) Right-hand handlebar switch.
- 6) Throttle twistgrip.
- 7) Front brake lever.
- 8) Gear change pedal.
- 9) Rear brake pedal.

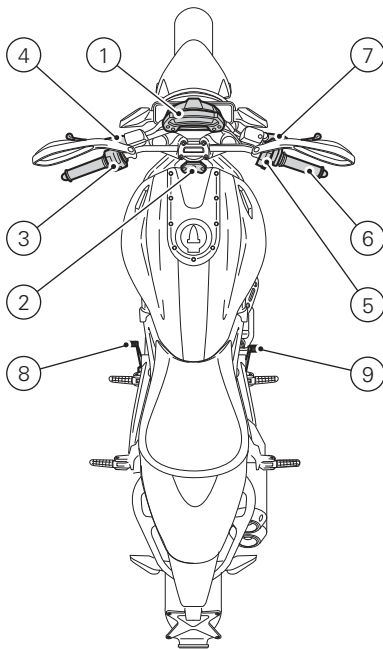





fig. 39

E

Ignition switch and steering lock

This is located in front of the fuel tank and has four positions:

- A)  : enables lights and engine operation;
- B)  : disables lights and engine operation;
- C)  : the steering is locked;
- D)  : parking light and steering lock.



Note

To move the key to the latter two positions, push it in before turning. The key can be removed in positions (B), (C) and (D).

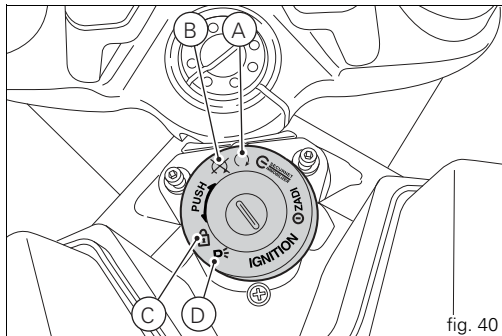



fig. 40

Left-hand handlebar switch

1) Dip switch, two-position light selector switch:

position  = low beam on;

position  = high beam on.

2) Switch  = 3-position turn indicator:

centre position = off;

position  = left turn;

position  = right turn.

To cancel the turn signal, press the lever once it has returned to the central position.

3) Button  = warning horn.

4) Button  = high beam flasher.

5) Two-position instrument panel control switch:

position "▲";

position "▼".

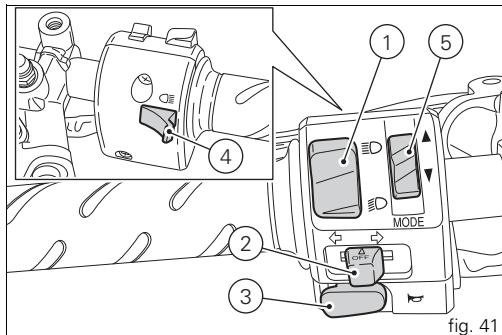

Clutch lever

Lever (1) disengages the clutch. It features a dial adjuster (2) for lever distance from the twistgrip on handlebar.

The lever distance can be adjusted through 10 clicks of the dial (2). Turn clockwise to increase lever distance from the twistgrip. Turn the adjuster counter clockwise to decrease lever distance.

When the clutch lever (1) is operated, drive from the engine to the gearbox and the rear wheel is disengaged. Correct use of the clutch lever is very important in all riding situations, especially when moving off.



Warning

Any adjustment of clutch lever must be carried out when motorcycle is stationary.



Important

Using the clutch properly will prolong the life of the engine and prevent any damage to components in the transmission.



Note

The engine can be started with the sidestand down and the gearbox in neutral. If starting with a gear engaged, pull in the clutch lever (in this case the sidestand must be up).

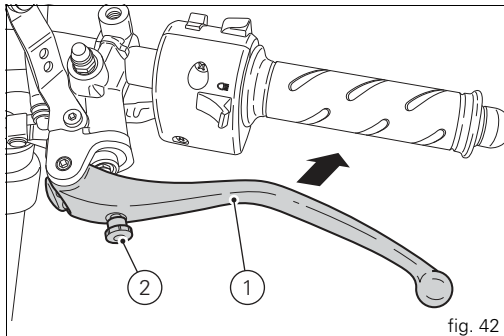



fig. 42

Right-hand handlebar switch

1) ENGINE STOP switch, two positions:

position  (RUN) = run.

position  (OFF) = stop.



Warning

This switch is mainly intended for use in emergencies when you need to stop the engine quickly. After stopping the engine, return the switch to the  position to enable starting.



Important

Riding with the headlight on and then shutting the engine off with the switch (1) while leaving the ignition key in the ON, position can cause the battery to discharge, as the headlight stays on.

2) Button  = engine start.

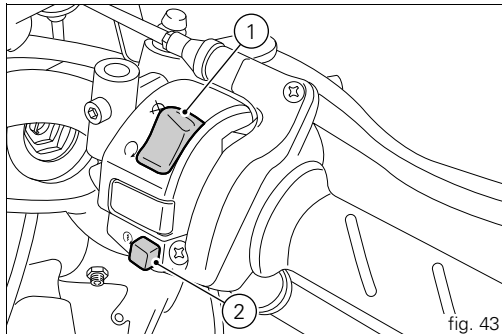

Throttle twistgrip

The twistgrip (1) on the right handlebar opens the throttles. When released, the twistgrip returns automatically to the initial position (idling speed).

Front brake lever

Pull the lever (2) towards the twistgrip to operate the front brake. The system is hydraulically assisted and you only need to pull the lever gently.

The brake lever has a knob (3) for adjusting the distance between lever and twistgrip on the semi handlebar. The lever distance can be adjusted by 10 clicks of the knob (3). Turn clockwise to increase lever distance from the twistgrip. Turn the adjuster counter clockwise to decrease lever distance.

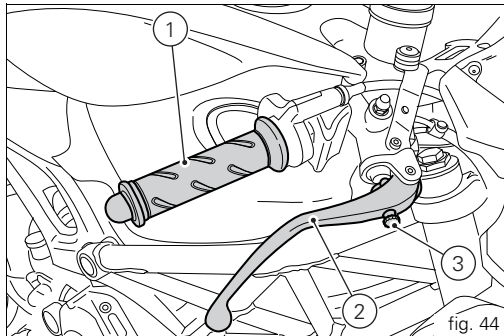

Warning

Before using these controls, read the instructions on page 81.

Warning

The front brake lever must be adjusted when the motorcycle is stationary.

Rear brake pedal (fig. 45)

Push down on the pedal (1) with your foot to operate the rear brake.

The system is controlled hydraulically.

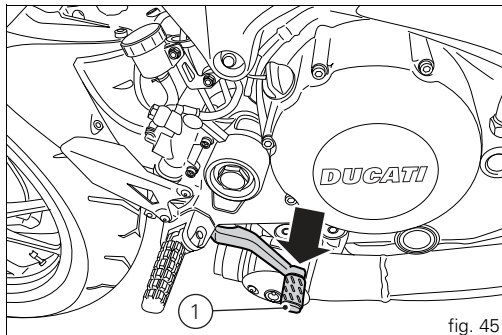

fig. 45

Gear change pedal (fig. 46)

The gearchange pedal has a central position N, with automatic return, and two directions of movement: down = press down the pedal to engage the 1st gear and to shift down. At this point the N warning light on the instrument panel will go out; upwards = lift the pedal to engage 2nd gear and then 3rd, 4th, 5th and 6th gears.

Each time you move the pedal you engage the next gear up, one gear at a time.

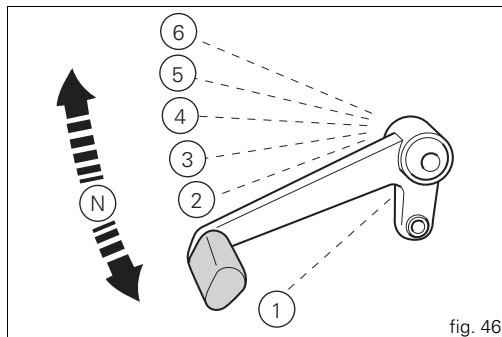

fig. 46

E Adjusting the position of the gearchange and rear brake pedals

The position of the gearchange and rear brake pedals in relation to the footrests can be adjusted to suit the requirements of the rider.

To adjust the position, proceed as follows:
hold the rod (1) and loosen the counter nuts (2) and (3).



Note

The locknut (2) has a left-hand thread.

Turn the rod (1) using an open-ended wrench on the flats to move the gear change pedal to the required position.

Tighten both counter nuts onto the rod.

To adjust the position of the rear brake pedal, proceed as follows:

loosen counter nut (4).

Turn the pedal travel adjustment screw (5) until the pedal is in the desired position.

Tighten the counter nut (4).

Operate the pedal by hand to check that there is 1.5 to 2 mm of freeplay before the brake bites.

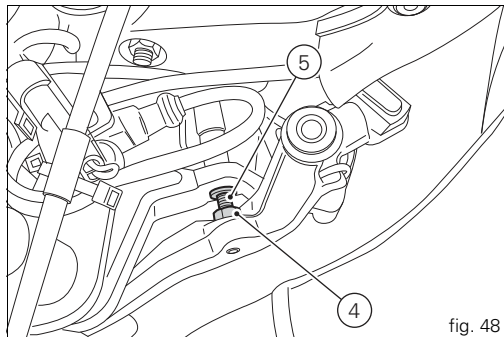
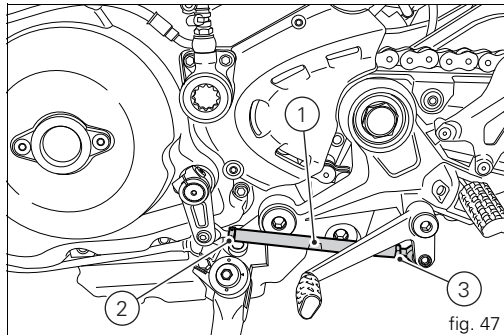

If not, adjust the length of the master cylinder pushrod as follows.

Slacken off the counter nut (6) on the pushrod.

Tighten the pushrod into fork (7) to increase play, or unscrew it to reduce it.

Tighten the counter nut (6) and recheck the pedal freeplay.



Note

Should the heel guard (8) somehow hinder rear brake adjustment operations, contact a Ducati Dealer or Authorised Service Centre to perform the maintenance.

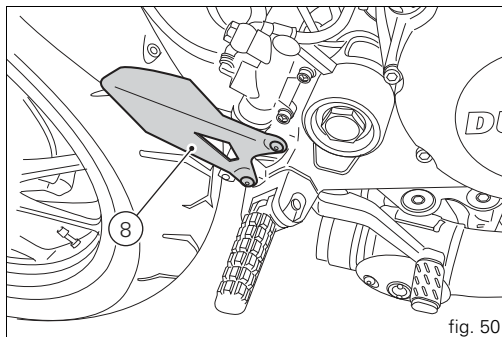
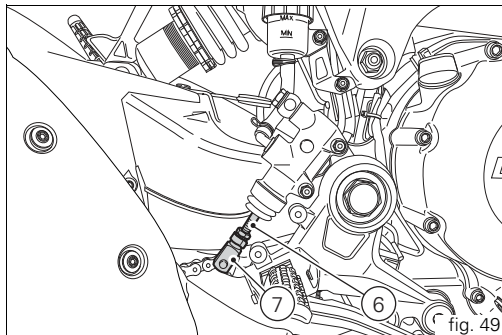

E Main components and devices

Position on the vehicle

- 1) Tank filler plug.
- 2) Seat lock.
- 3) Helmet cable pin.
- 4) Side stand.
- 5) Rear-view mirrors.
- 6) Rear shock absorber adjusters.
- 7) Catalytic converter.

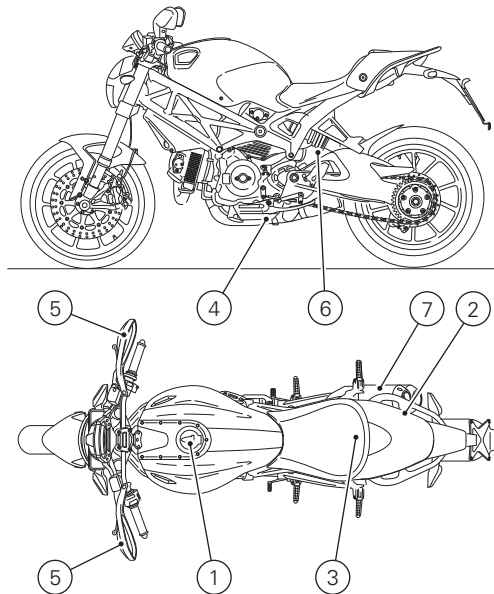

fig. 51

Tank filler plug

Opening

Raise the cover (1) and insert the key into the lock. Give the key a 1/4 turn clockwise to unlock.
Lift the cap.

Closing

Close the cap with the key inserted and push it into its seat. Turn the key anticlockwise to the initial position and remove it. Replace the lock cover (1).



Note

The cap can only be closed with the key inserted.



Warning

Always make sure you have properly refitted (see page 83) and closed the plug after each refuelling.

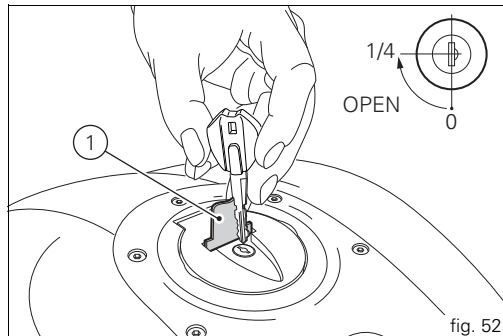

Seat lock

E

Opening

Insert the key in the lock and simultaneously apply downward pressure in the area of the catch to release the pin. Pull the seat backwards to release it from the front catches.

Closing

Make sure all parts are correctly arranged and secured in the underseat compartment. Insert the front ends of the seat base under the U bolt in the frame, then push the rear end of the seat until you hear the bolt in the lock click into place. Make sure that the seat is firmly secured to the frame and remove the key from the lock.

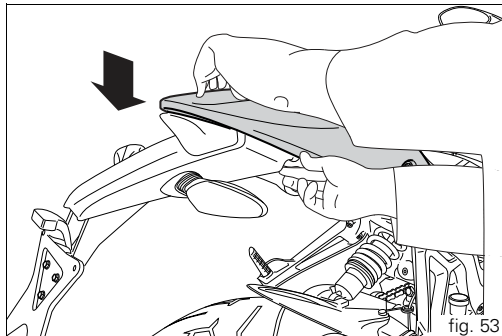

Helmet cable



Note

Helmet cable (1, fig. 54) can be found inside the tool kit, see "Tool kit and accessories," on page 81.

Pass the cable through the helmet and insert the end of the cable in the pin (2, fig. 54). Leave the helmet hanging and refit the seat to hold it in place.



Warning

This device protects the helmet against theft when the motorcycle is parked. Do not leave the helmet attached when riding the motorcycle; it could interfere with your movements and cause loss of control of the motorcycle.

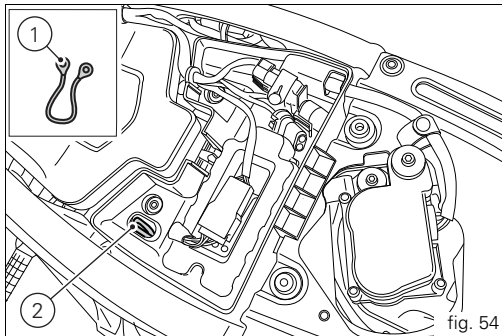

Side stand

Important

Before lowering the side stand, make sure that the supporting surface is hard and flat.

Do not park on soft ground, gravel or on asphalt softened by the sun etc. or the motorcycle may fall over.

When parking on a slope, always park with the rear wheel on the downhill side.

To pull down the side stand, hold the motorcycle handlebar with both hands and push down on the sidestand (1) with your foot until it is fully extended. Tilt the motorcycle until the sidestand is resting on the ground.

Warning

Do not sit on the motorcycle when it is supported on the sidestand.

To raise the sidestand to rest position (horizontal position), tilt the motorcycle to the right and, at the same time, lift the stand (1) with your foot.



Note
Check for proper operation of the stand mechanism (two springs, one inside the other) and the safety sensor (2) at regular intervals.



Note
The engine can be started with the sidestand down and the gearbox in neutral. If starting with a gear engaged, pull in the clutch lever (in this case the sidestand must be up).

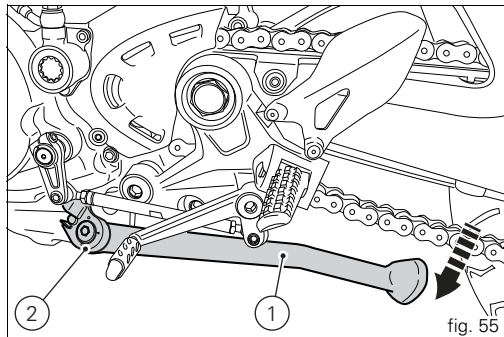

Front fork adjusters

The front fork used on this motorcycle has rebound, compression and spring preload adjustment.

This adjustment is done using the outer adjusters:

- 1) to adjust rebound damping;
- 2) to adjust internal spring preload;
- 3) to adjust compression damping.

Park the motorcycle in a stable position on its side stand.
Turn the adjuster (1) at the top end of each fork leg with a flat screwdriver to adjust rebound damping.
Turn the adjuster (3) at the rear end of the wheel shaft pinch bolts with a flat screwdriver to adjust compression damping.
To change the preload of the spring inside each fork leg, turn the hex. adjuster (2) with a 22 mm hexagon wrench.
As you turn the adjusters (1 and 3), you will hear them click. Each click identifies a setting.
Tighten the adjuster fully to achieve the hardest damping.

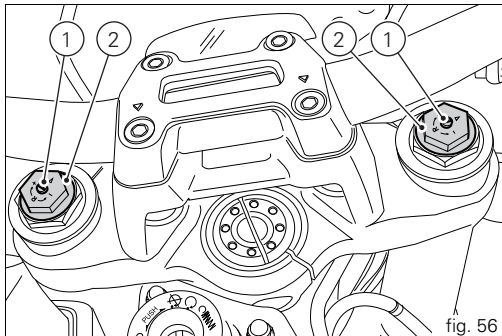

E

This will be your starting point. Now turn the adjuster counter clockwise and listen for the clicks that identify setting positions no. 1, 2 and so on.

STANDARD factory setting is as follows:

Compression: 1 and a half turn from Max (fully closed);

Rebound: 1 turn from Max (fully closed).

Spring preload: 7 turns more from Min. (fully not preloaded).

Every full turn corresponds to 1 mm of spring preload (total 15 mm).



Important

Adjust both fork legs to same settings.

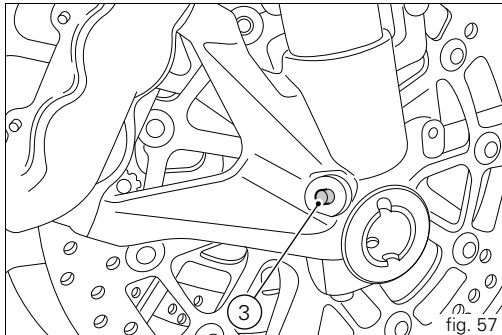

Rear shock absorber adjusters

The shock absorber has external adjusters that enable you to adjust the setup to suit the load on the motorcycle.

The adjuster (1) located on the left-hand side, where the upper end of the shock absorber is attached to the rear subframe, controls rebound damping.

Turn the adjuster (1) clockwise to increase damping, or counter-clockwise to reduce damping.

The two nuts (2) on the upper part of the shock absorber serve to adjust the preload on the external spring. To change spring preload, slacken off the upper lock nut. Then **TIGHTEN** or **SLACKEN** the lower ring nut to **INCREASE** or **DECREASE** spring preload.

STANDARD setting from the fully closed position (clockwise):

- unscrew adjuster (1) by 8 clicks from Max (fully closed).
Spring preload: 20 mm from Min (fully unloaded).

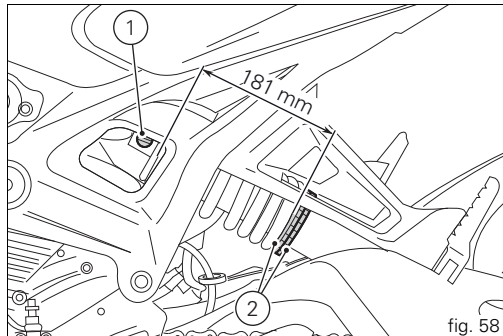

Warning

When adjusting the spring preload, do not exceed a spring length of 181 mm to avoid damaging the swingarm.

Warning

The shock absorber is filled with gas under pressure and may cause severe damage if taken apart by unskilled persons.

Riding the motorcycle

Running-in recommendations

Maximum rpm (fig. 59)

Rpm limits to be observed during the running-in period and in normal use:

- 1) Up to 1000 km
- 2) From 1000 to 2500 km

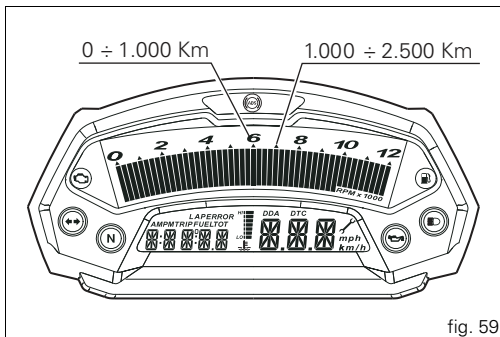

fig. 59

Up to 1000 km

During the first 1000 km, keep an eye on the rev counter. It should never exceed 5,500-6,000 rpm.

During the first hours of riding, it is advisable to continuously vary the load on the engine and the rpm, though still keeping within the above limits.

For this reason, roads with numerous bends and hilly areas are ideal for running in the engine, brakes and suspension.

For the first 100 km, use the brakes gently. Do not brake violently or keep brake applied for too long. This will enable a correct break-in of the friction material on the brake pads against the brake discs.

To allow all the mechanical moving parts in the motorcycle to adapt to one another, and to avoid shortening the life of the main engine components, it is advisable to avoid sudden acceleration and running the engine at high rpm for too long, especially uphill.

It is also advisable to check the drive chain frequently and ensure that it is lubricated as required.

From 1000 to 2500 km

At this point, you can ask for more power from the engine, being careful, however, never to exceed 7,000 rpm.



Important

Throughout the running-in period, be careful to stick to the recommended maintenance schedule and periodic service intervals indicated in the warranty booklet. Failure to comply with these rules will release Ducati Motor Holding S.p.A. from any liability whatsoever for resulting engine damage or shorter engine life.

Keeping to the running-in recommendations will ensure longer engine life and reduce the need for overhauls and re-tuning.

Pre-ride checks



Warning

Failure to carry out these checks before starting may result in damage to the motorcycle and injury to rider.

Before starting, check the following points:

FUEL LEVEL IN THE TANK

Check fuel level in the tank. Fill tank if needed (page 83).

ENGINE OIL LEVEL

Check the oil level in the sump through the sight glass.

Top up if needed (page 116).

BRAKE AND CLUTCH FLUID

Check the fluid levels in the respective reservoirs.

TYRE CONDITION

Check tyre pressure and condition (page 114).

CONTROLS

Operate the brake, clutch, gearchange and throttle controls (lever, pedal and twistgrip) and check that they function correctly.

LIGHTS AND INDICATORS

Make sure lights, indicators and horn work properly. Replace any burnt-out bulbs (page 111).

KEY-OPERATED LOCKS

Check that the fuel filler cap and the seat are locked.

STAND

Make sure side stand operates smoothly and is in the correct position (page 72).

ABS light

After key-on, the ABS light (10, fig. 5) remains on when the vehicle speed exceeds 5 km/h; the light turns off to indicate that the ABS system is functioning properly.



Warning

In case of malfunction, do not ride the motorcycle and contact a Ducati Dealer or authorised Service Centre.

ABS device

Check that the front (1) and rear (2) phonic wheels are clean.



Warning

Clogged reading slots would compromise system proper operation.

It is recommended to disable ABS system in case of muddy road surface because under this condition the system might be subject to sudden failure.



Warning

Prolonged rearing could deactivate the ABS system.

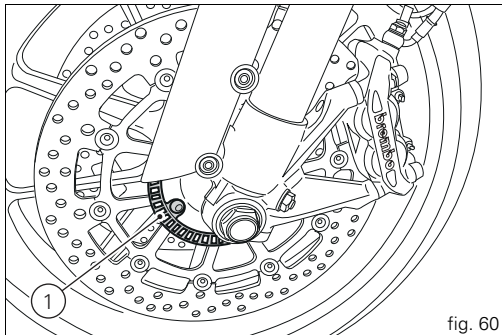

fig. 60

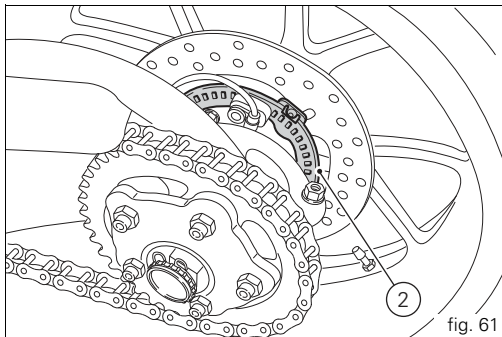

fig. 61

Starting the engine



Note

Follow the “High ambient temperature” procedure to start the engine when it is already warm.



Warning

E Before starting the engine, familiarise yourself with the controls that you will use when riding.

Normal ambient temperature

(between 10 °C/50 °F and 35 °C/95 °F):

- 1) Move the ignition switch to (1). Make sure both the green light N and the red light  on the instrument panel come on.



Important

The oil pressure light should go out a few seconds after the engine has started (page 11).



Warning

The side stand must be fully up (in horizontal position) as its safety sensor prevents engine start when down.



Note

The engine can be started with the sidestand down and the gearbox in neutral. If starting with a gear engaged, pull in the clutch lever (in this case the sidestand must be up).

- 2) Check that the stop switch (2, fig. 63) is positioned to  (RUN), then press the starter button (3, fig. 63).

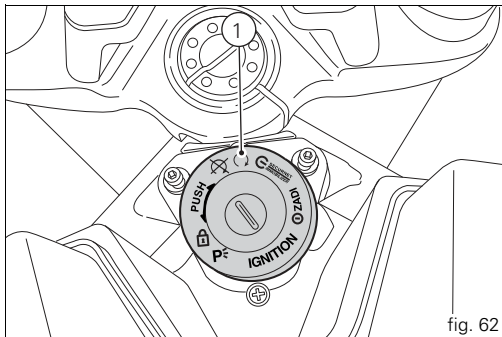

fig. 62

E Allow the engine to start on its own, without turning the throttle twistgrip.



Note

If the battery is flat, the system automatically disables operation of the starter motor.



Important

Do not rev the engine when cold. Allow some time for the oil to warm up and reach all points that need lubricating.

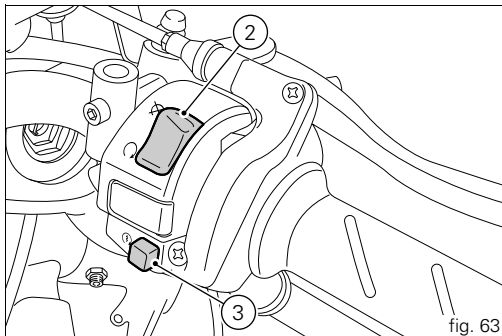

Moving off

- 1) Disengage the clutch squeezing the control lever.
- 2) Push down on gear change lever sharply with the tip of your foot to engage the first gear.
- 3) Speed up the engine, turn the throttle twistgrip, gradually release the clutch lever at the same time.
The motorcycle will start moving.
- 4) Let go of clutch lever and speed up.
- 5) To shift up, close the throttle to slow down engine, disengage the clutch, lift the gear change lever and let go of clutch lever.

To change down, proceed as follows: release the twistgrip, pull the clutch lever, increase engine speed for a moment to allow the gears to synchronise, shift down and release the clutch.

Use the controls intelligently and promptly: when riding uphill, do not hesitate to shift down as soon as the motorcycle starts to slow down, so you will avoid stressing the engine and the motorcycle abnormally.



Important

Avoid sudden acceleration, as this may lead to misfiring and transmission snatching. The clutch lever should not be held in longer than necessary after a gear is engaged, otherwise friction parts may overheat and wear out.



Warning

Prolonged rearing could deactivate the ABS system.

Braking

Slow down in time, change down to use the engine brake, then apply both brakes. Pull in the clutch lever before the motorcycle comes to a stop to prevent the engine stalling.

ABS system

Using the brakes correctly under adverse conditions is the hardest – and yet the most critical - skill to master for a rider. Braking is one of the most difficult and dangerous moments when riding a two wheeled vehicle: the possibility of falling or having an accident during this difficult moment is statistically higher than any other moment. A locked front wheel leads to loss of traction and stability, resulting in loss of control.

The Anti-Lock Brake System (ABS) has been developed to enable riders to use the vehicles braking force to the fullest possible amount in emergency braking or under poor pavement or adverse weather conditions.

ABS uses hydraulics and electronics to limit pressure in the brake circuit when a special sensor mounted to the wheel signals the electronic control unit that the wheel is about to lock up.

This avoids wheel lockup and preserves traction. Pressure is raised back up immediately and the control unit keeps controlling the brake until the risk of a lockup disappears.

Normally, the rider will perceive ABS operation as a harder feel or a pulsation of the brake lever and pedal.

The front and rear brakes use separate control systems, meaning that they operate independently. Likewise, the ABS is not an integral braking system and does not control both the front and rear brake at the same time.

If desired, the system can be deactivated from the instrument panel, using the “ABS disabling function” (see page 38).



Warning

With the ABS system deactivated, the vehicle maintains the characteristics of the standard braking system, therefore the use of only one of the brakes reduces the motorcycle's braking efficiency. Never use the brake controls harshly or suddenly as you may lock the wheels and lose control of the motorcycle. When riding in the rain or on slippery surfaces, braking capacity is significantly reduced. Always use the brakes very gently and carefully when riding under these conditions. Any sudden manoeuvres may lead to loss of control.

When tackling long, steep downhill road tracts, shift down gears to use engine braking. Apply one brake at a time and use brakes sparingly. Keeping the brakes applied continuously causes the friction material to overheat and dangerously reduces braking effectiveness. Tyre inflation pressures below the specified value will reduce braking efficiency, and compromise steering precision and roadholding on bends.

Stopping the motorcycle (fig. 64)

Reduce speed, shift down and release the throttle twistgrip. Change down to engage first gear and then neutral. Apply the brakes and bring the motorcycle to a complete stop. To switch the engine off, simply turn the key to (2).

Important

Never leave the key in the ON position (1) when engine is stopped, or this will damage the electric components.

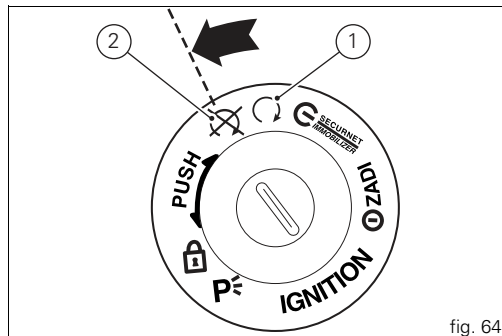

fig. 64

Refuelling (fig. 65)

Never overfill the tank when refuelling. The fuel level should always be below the rim of the filler recess.

Warning

Use fuel with low lead content and an original octane number of at least 95.

Be sure there is no fuel trapped in the filler recess.

Warning (USA version)

Use low-lead fuel with a minimum octane rating of 90 (RON+MON)/2.

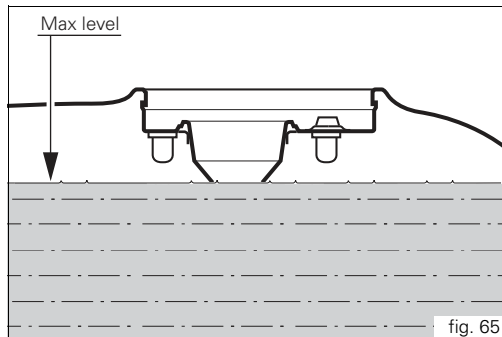

fig. 65

Parking

Stop the motorcycle, then put it on the side stand (see page 72).

To prevent theft, turn the handlebar fully left and turn the ignition key to (3).

If you park in a garage or other indoor area, make sure that there is proper ventilation and that the motorcycle is not near a source of heat.

You may leave the parking lights on by turning the key to (4).

Important

Do not leave the key turned to position (4) for long periods or the battery will run down. Never leave the motorcycle unattended with the ignition key inserted.

Warning

The exhaust system might be hot, even after engine is switched off; take special care not to touch exhaust system with any part of your body and do not park the motorcycle next to inflammable material (wood, leaves etc.).

Warning

Using padlocks or other locks designed to prevent movement of the motorcycle (such as brake disc locks, rear sprocket locks, and so on) is very dangerous, and may impair motorcycle operation and the safety of rider and passenger.

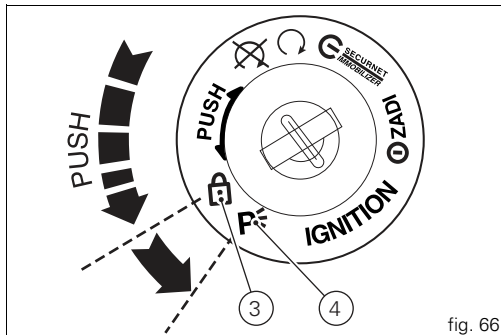

fig. 66

Tool kit and accessories

The tool kit (2) is located under the seat (1).

The tool kit includes:

- fuse pliers;
- 8/10 double-ended wrench;
- helmet lock cable;
- screwdriver;
- screwdriver handle;
- 16 mm box wrench;
- 8 mm rod;
- 3 mm Allen wrench;
- 5 mm Allen wrench;
- 6 mm Allen wrench.

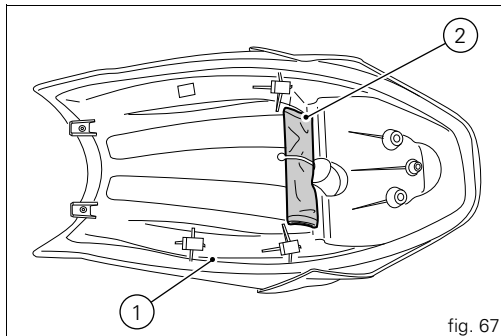

Main maintenance operations

Changing the air filter

Important

Have the air filter maintenance performed at a Ducati Dealer or authorised Service Centre.

Checking brake and clutch fluid levels

(fig. 68)

The levels should not fall below the MIN marks on the respective reservoirs.

If level drops below the limit, air can get into the circuit and make the system ineffective.

Fluids must be topped up and changed at the intervals specified in the scheduled maintenance table reported in the Warranty Booklet; please contact a Ducati Dealer or authorised Service Centre.

Important

It is recommended that all brake and clutch hoses be renewed every 4 years.

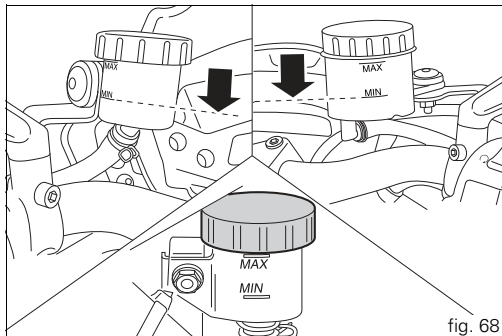

Clutch system

If the control lever has excessive play and the transmission snatches or jams when engaging a gear, this indicates that air is in the circuit. Contact your Ducati Dealer or authorised Service Centre to have the system inspected and air drained out.



Warning

The level of clutch fluid tends to increase in the reservoir as the friction material on the clutch plates wears out. Do not exceed the specified level (3 mm above the minimum level).

Brake system

If you find excessive play on brake lever or pedal and brake pads are still in good condition, contact your Ducati Dealer or authorised Service Centre to have the system inspected and any air drained out of the circuit.



Warning

Brake and clutch fluid can damage paintwork and plastic parts, so avoid contact.

Hydraulic oil is corrosive; it may cause damage and lead to severe injuries.

Never mix fluids of different qualities.

Check that the seals are in good condition.

E Checking brake pads for wear (fig. 69) and (fig. 70)

Check brake pads wear through the inspection hole in the callipers.
Change both pads if friction material thickness of even just one pad is about 1 mm.



Warning

Friction material wear beyond this limit would lead to metal support contact with the brake disc thus compromising braking efficiency, disc integrity and rider safety.



Important

Have the brake pads replaced at a Ducati Dealer or authorised Service Centre.

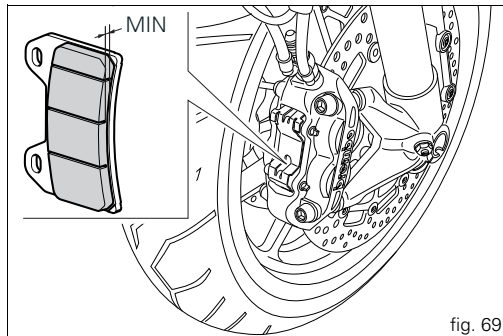

fig. 69

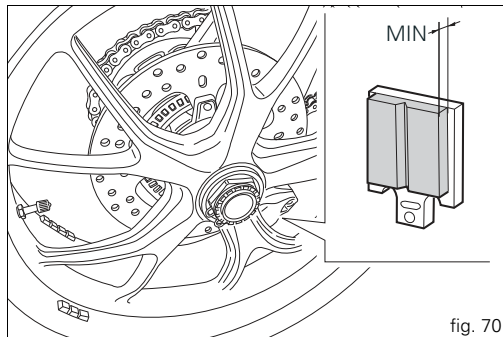



fig. 70

Lubricating cables and linkages

The condition of the throttle cables and choke cable sheaths should be checked at regular intervals. There should be no signs of pinching or cracking on the outer plastic sheath. Operate the control to check that the inner cable slides smoothly: if you feel any friction or catching, have the cable replaced by a Ducati Dealer or Authorised Service Centre. To avoid this kind of problem, periodically lubricate the ends of each control cable with SHELL Advance Grease or Retinax LX2.

Concerning the throttle cable, it is advised to open the housing, unscrewing the two fastening screws (1) and then grease the cable end and the pulley.

Warning  Close the twistgrip housing carefully, inserting the cable in the race.

Refit the housing and tighten the screws (1) to 1.8 Nm.

To ensure smooth operation of the side stand pivot, remove dirt and apply SHELL Alvania R3 grease to all friction points.

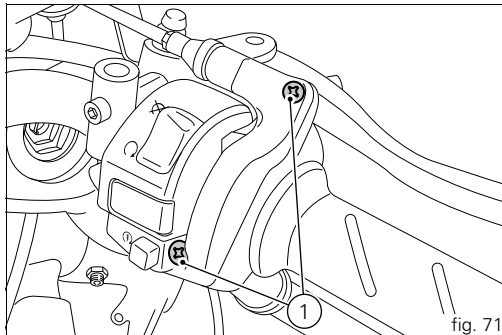

E Throttle cable adjustment (fig. 72)

In all steering positions, the throttle twistgrip should have about 2 to 4 mm of free travel, measured at the outer edge of the twistgrip housing. If necessary, adjust it with the adjuster (1) located on the twistgrip.

Charging and maintenance of the battery during winter storage

Your motorcycle is equipped with a connector to which you can connect a special battery charger available from our sales network.

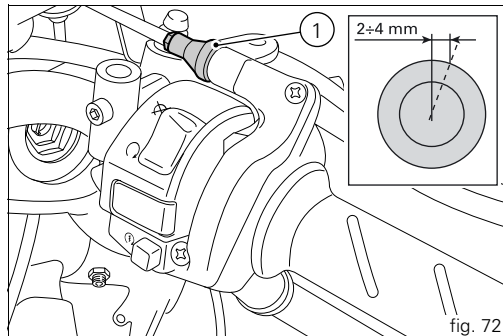

Removal of the battery



Important

For battery removal, ALWAYS contact a Ducati Dealer or authorised Service Centre.

Remove the seat (page 70).

Unscrew the screws (1) and (2) securing the front tank cover (3) but do not remove the cover.

Unscrew the screws (4) and (5) and recover the nylon washers (7).

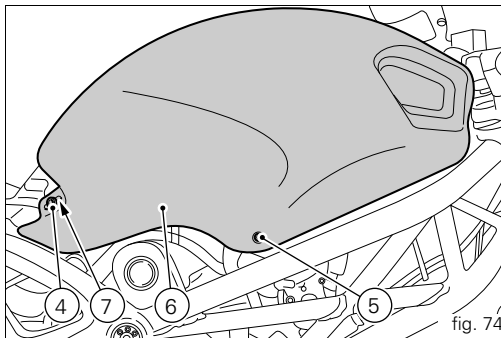
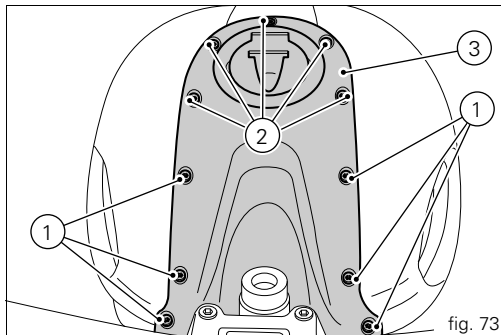

E

Slide off the right-hand tank cover (6), releasing the tabs (A) in the corresponding slots (B) in the rear cover.

Repeat the above operations to remove the left-hand tank cover.

Remove the front tank cover (3) and recover the bushes (C) and the spacers (D).

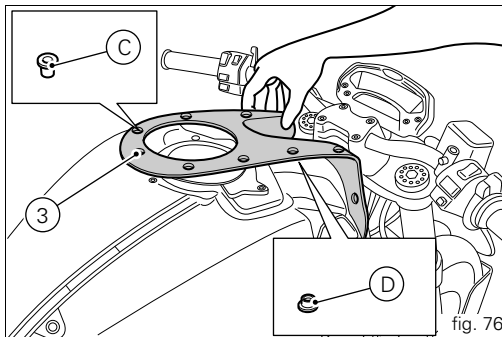
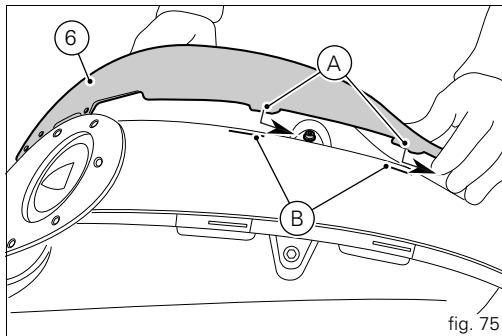

Unscrew the retaining screw (E).
Release the oil hoses from the clips (F).
Unscrew the two retaining screws (9) and release the cover (8).
Withdraw the breather hose (10) from the cover (8).
Withdraw the hose (10) upwards, leaving it attached to the tank breather and drain hose unions.

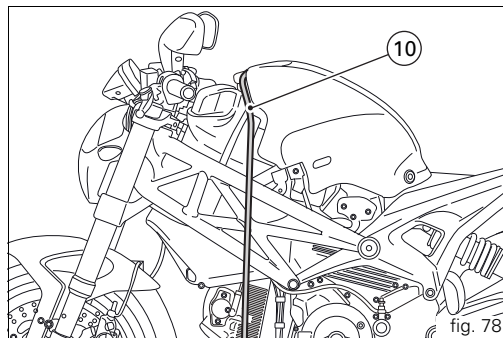
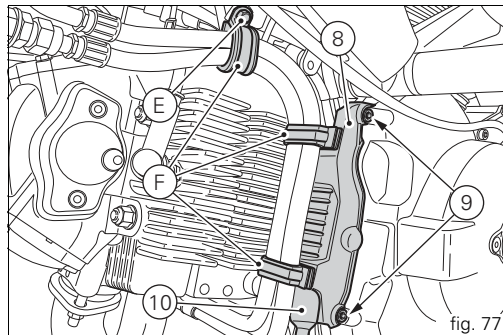

Working on the right-hand side of the motorcycle, disconnect the wiring connector (11) of the fuel level sensor from the main wiring harness, unscrew the screw (12) securing the side of the tank to the frame and recover the washer (13).

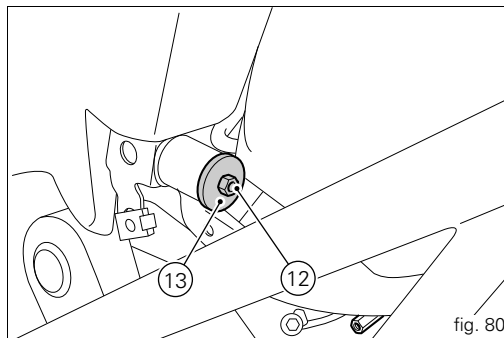
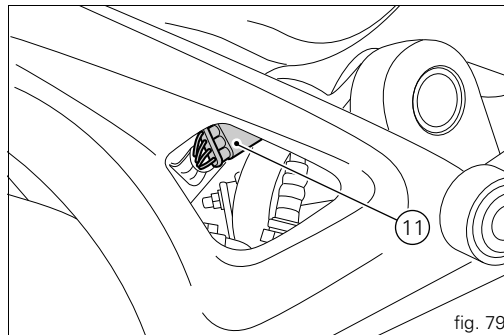

Unscrew the screw (14) and recover the washer (15).
Release the fuel hoses (G) from the clips (H).

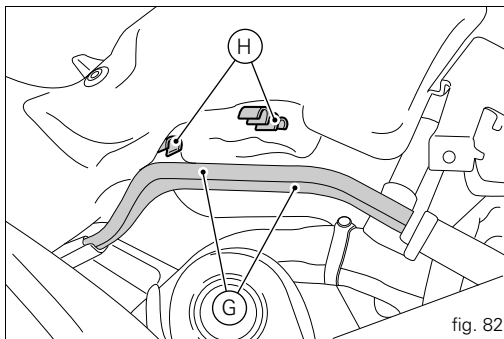
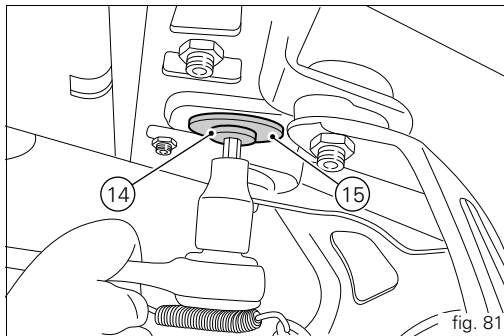

E Release the lambda sensor cable (L) from the tab (M) on the tank flange cover.



Warning

Before removing the flange cover (16), make sure the tank is empty and position a rag to collect any spilt fuel.

Hold the fuel tank in a raised position and remove the flange cover (16) by unscrewing the nuts (17).

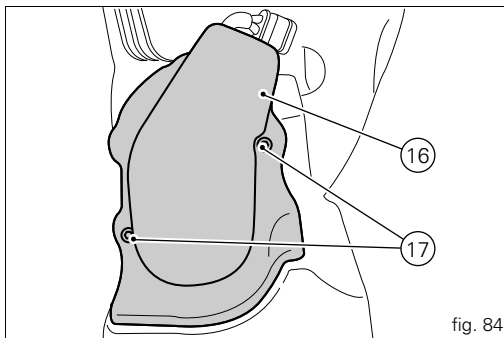
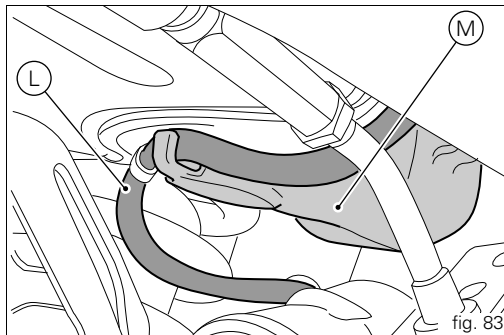

Disconnect the quick-release fittings (18) from the flange. Remove the elastic retaining strap (19), remove the caps from the terminals, unscrew the screws (22) on terminal clamps (20) and (21), always starting with the negative terminal, then remove the battery from its seating.

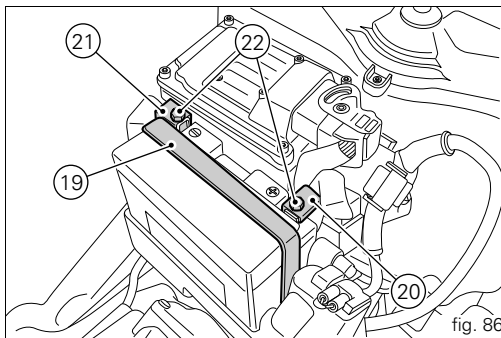
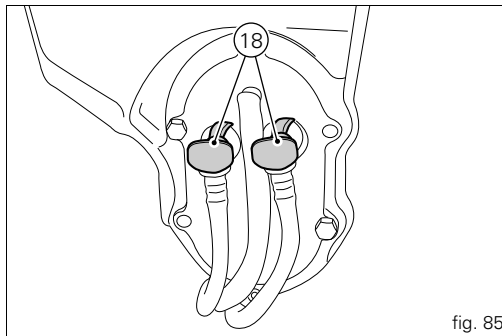

Refitting the battery

Important

For battery removal, ALWAYS contact a Ducati Dealer or authorised Service Centre.

Install the battery in the battery support and secure it with the elastic retaining strap (19).

Warning

Connect the positive lead (20) to the positive terminal and the negative lead (21) to the negative terminal, as shown in the photo.

Insert the screws (22) in the terminals (20) and (21), always starting with the positive terminal (red lead).

Warning

Position the leads (20) and (21) as shown in the photo.

Tighten the screws (22) to a torque of $10 \text{ Nm} \pm 10\%$.
Apply grease around the battery terminal clamps to prevent oxidation.

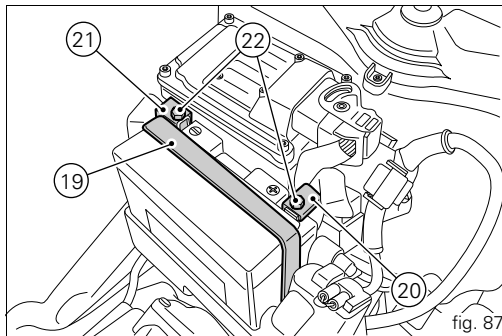



Warning

If it was necessary to remove the tank from the vehicle, refit it by inserting the front pins (N) into their seats in the frame.



Important

To refit the battery, ALWAYS contact a Ducati Dealer or authorised Service Centre.

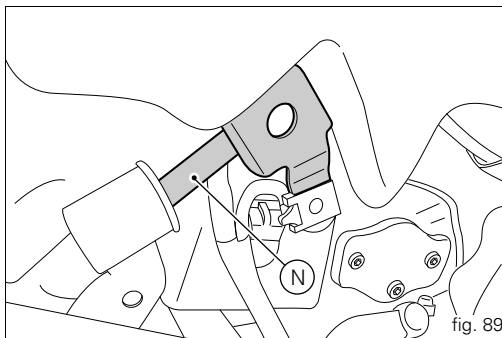
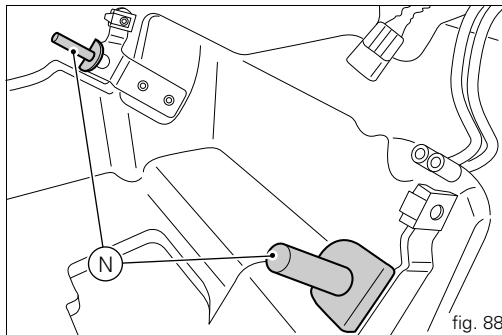

E

While holding the tank in the raised position, connect the quick-release fittings (18) to the flange and refit the flange cover (16) inserting and tightening the nuts (17) to a torque of $3 \text{ Nm} \pm 0.3\%$.

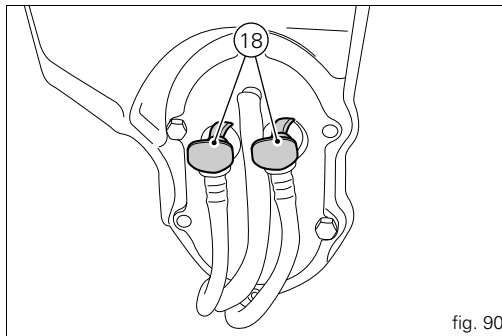

fig. 90

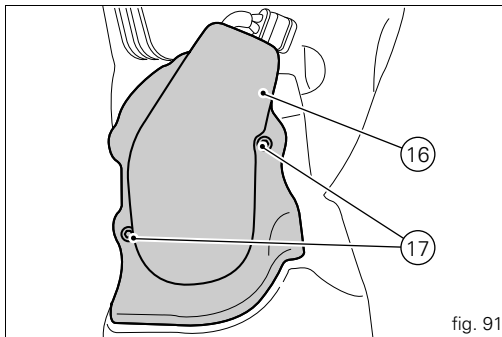
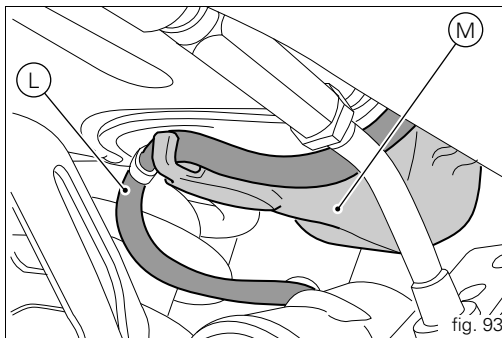
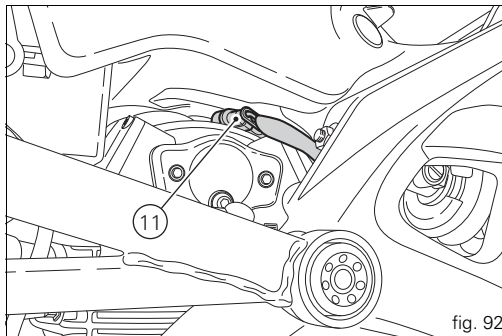

fig. 91

Connect the fuel sensor (11) to the main wiring harness.
Position the lambda sensor cable (L) in the specific tab (M) on
the tank flange cover and secure it with a clamp.

Important

With the fuel tank lowered, the fuel level sensor
connector (11) should rest on the vertical cylinder head, as
shown in the figure.



E Attach the fuel hoses (G) to the clips (H).
Secure the tank to the frame with the screw (12) and the washer (13).
Tighten the screw (12) to a torque of $10 \text{ Nm} \pm 10\%$.

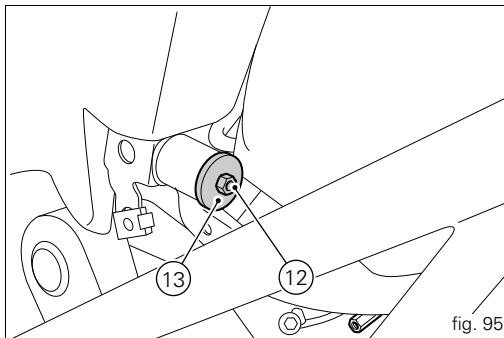
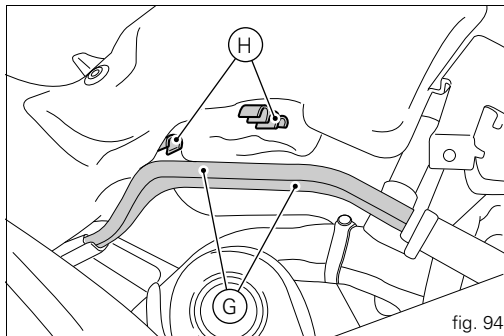

Secure the tank to the subframe with the screw (14) and the washer (15).

Tighten the screw (14) to a torque of $10 \text{ Nm} \pm 10\%$, using a 5 mm Allen wrench to counterhold the threaded insert (P) located on the upper part of the tank.

Important

The threaded insert (P) is not present in the USA version.

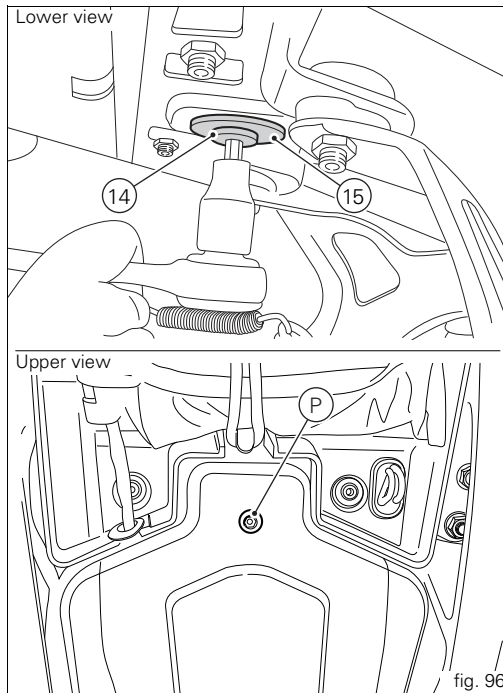

E

Locate the breather/drain hose (10) on the motorcycle and secure it in position by refitting the cover (8). Fit the two screws (9), remembering to fit the longest screw in the lower hole, and tighten to a torque of 10 Nm. Secure the oil hoses with the clips (F) and tighten the screw (E) to a torque of 10 Nm \pm 10%.

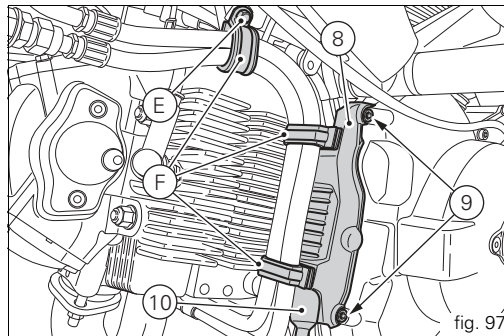
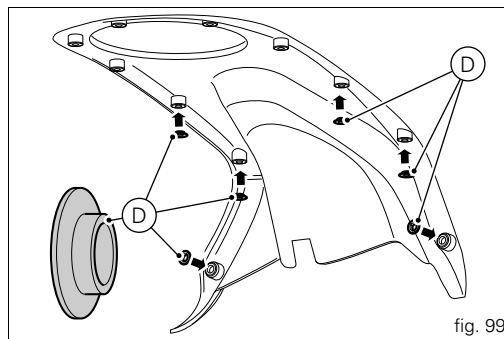
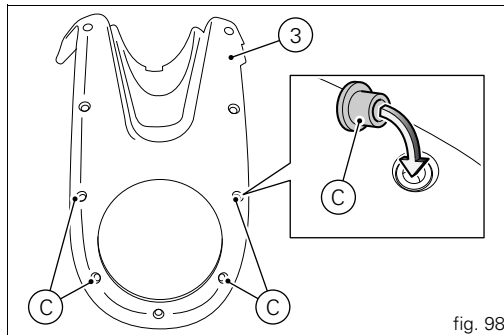
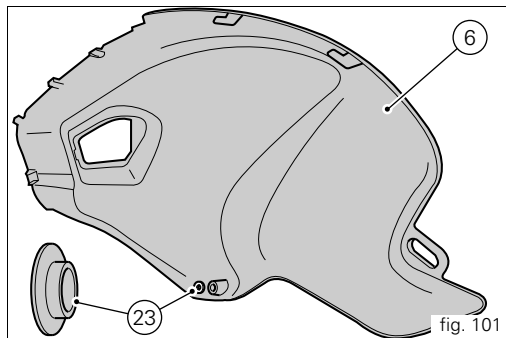
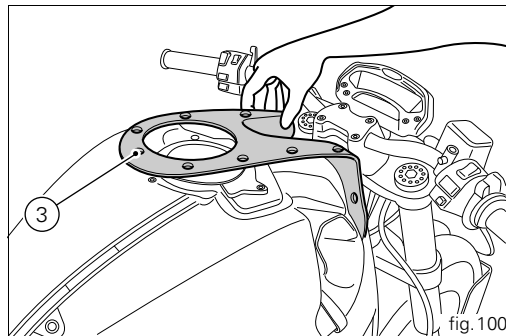

fig. 97

Check that the four bushes (C) are installed on the front tank cover (3) with the larger diameter side facing upwards and the spacers (D).



E Locate the front tank cover (3) on the fuel tank.
Insert the spacer (23) in the holes in the right tank cover (6).



Refit the right-hand tank cover (6), inserting the tabs (A) in the corresponding slots (B) in the rear cover.



Note

Insert the lugs (O) under the front tank cover (3).

Repeat the above operations to refit the left-hand tank cover. Insert the screws (1) and (2) in the front tank cover (3), starting with the front screws (1).

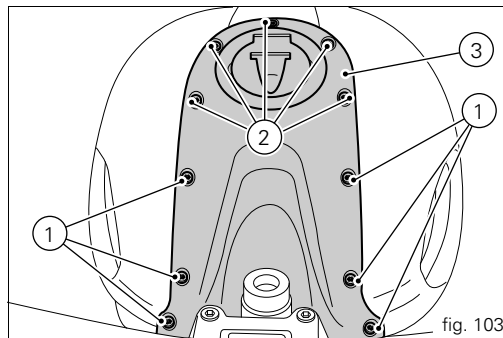
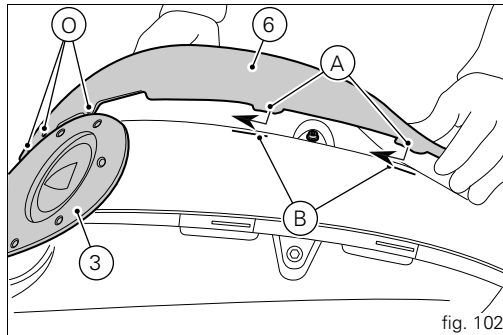

E

Insert the right (6) and left tank retaining screws (4), with nylon washers (7), and (5). Tighten the screws (1) and (2) to a torque of $2 \text{ Nm} \pm 10\%$, starting from the screws (2) around the cap. Tighten the screws (4) and (5) to a torque of $2 \text{ Nm} \pm 10\%$. Refit the seat (page 70).

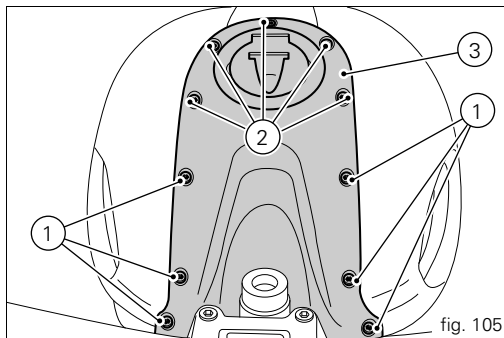
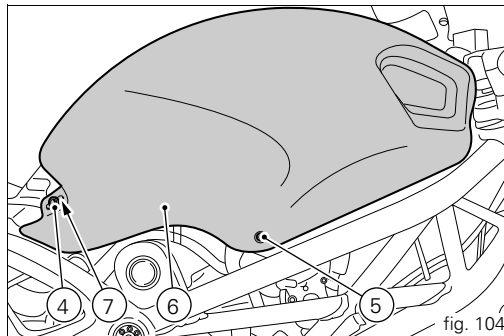

Checking drive chain tension

Important

Have chain tension adjusted by a Ducati Dealer or authorised Service Centre.

Make the rear wheel turn until you find the position where chain is tightest.

Set the vehicle on the side stand. Lower the chain by pressing down on it only with your finger at the point of measurement, and release.

Measure the distance (A) between the centre of the chain pins and the aluminium section of the swingarm.

It must be: $A = 61 - 63 \text{ mm}$

Important

If the drive chain is too tight or too slack, adjust it so that tension reading will fall within specified range.

Warning

Correct tightening of swingarm screws (1, fig. 107) is critical to rider and passenger safety.

Important

Improper chain tension will lead to early wear of transmission parts.

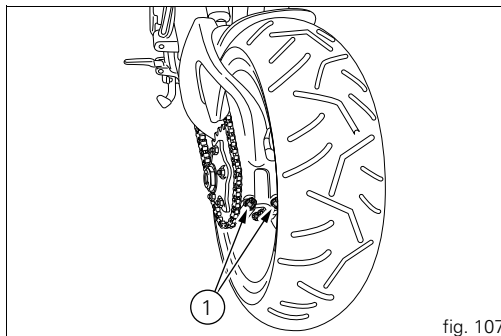
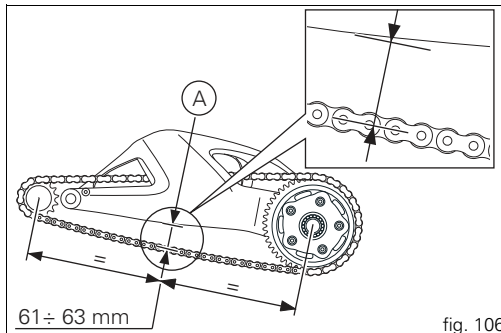

E

Lubricating the drive chain

The chain fitted on your motorcycle has O-rings to protect its moving parts from dirt, and to hold the lubricant inside.

So as not to damage these seals when cleaning the chain, use special solvents and avoid aggressive washing with high-pressure steam cleaners. After cleaning, blow the chain dry with compressed air or wipe with an absorbent material, then lubricate each link with SHELL Advance Chain or Advance Teflon Chain.

Important

Using non-specific lubricants may cause severe damage to the chain and the front and rear sprocket.

Changing bulbs

Before replacing a burnt-out bulb, make sure that the new one matches the voltage and wattage specifications in the "Electric System" paragraph on page 131.



Important

Have the bulbs changed at a Ducati Dealer or authorised Service Centre.

Turn signals (fig. 108)

Loosen the screw (1) and detach the lens (2) from the turn signal support.

The bulb has a bayonet-type end fitting: to remove it, push it in and turn it counter-clockwise. Push in the new bulb and turn it clockwise until it clicks into place. Refit the cup by inserting the tab into the corresponding slot in the turn signal support.

Refit and tighten the screw (1).

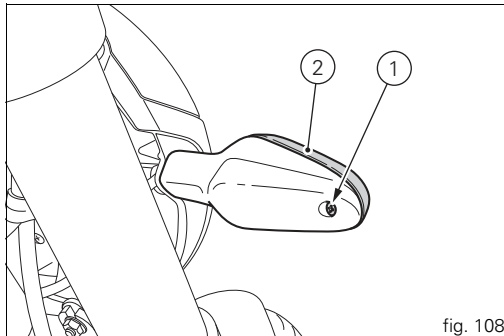

E Beam setting (fig. 109)

To check the headlight aim, place the motorcycle upright with the tyres inflated to the correct pressure and one person sitting astride the motorcycle. The motorcycle should be perfectly vertical, with its longitudinal axis at right angles to a wall or screen at a distance of 10 metres. Draw a horizontal line at the height of the centre of the headlamp and a vertical one at the longitudinal axis of the motorcycle.

If possible, perform this check in dim light.

Switch on the low beam headlight.

The height of the upper limit between the dark area and the lit area must not be more than nine tenths of the height of the centre of the headlamp from the ground.



Note

This is the procedure specified by Italian regulations for checking the maximum height of the light beam.

Owners in other countries should adapt this procedure to the regulations in force in the country where the motorcycle is used.

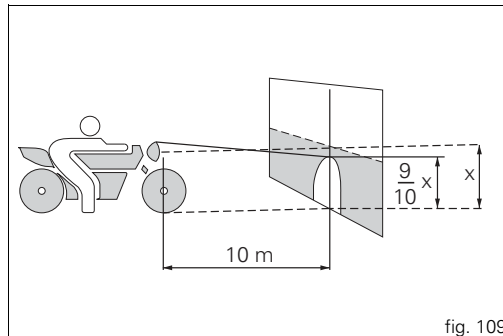

To adjust the headlight beam vertically, turn the screws (1),
for horizontal adjustment, turn the screw (2).



Warning

The headlight might fog up if the vehicle is used under
the rain or after washing.
Switch headlight on for a short time to dry up any
condensate.

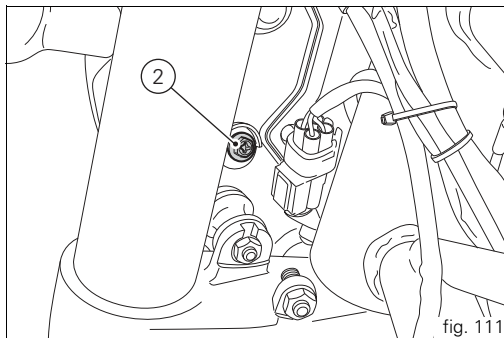
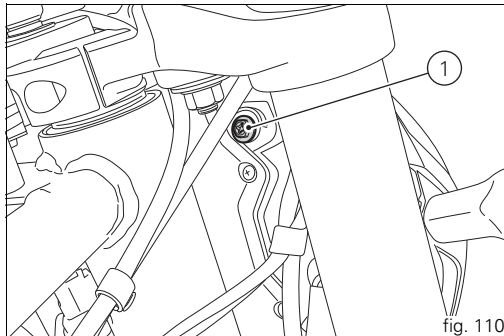

Tyres

Front tyre pressure:
2.25 bar - 2.29 kg/cm²

Rear tyre pressure:
2.50 bar - 2.55 kg/cm²

As tyre pressure is affected by changes in temperature and altitude; check and adjust them whenever you are riding in areas where there are large variations in temperature or altitude.

Important

Check and adjust the pressures with the tyres cold. To avoid front wheel rim distortion, when riding on bumpy roads, increase front tyre pressure by 0.2 - 0.3 bar.

Repairing or renewing tyres

With minor punctures, tubeless tyres take a long time to deflate, as they tend to hold the air inside. If you find low pressure on one tyre, check the tyre for punctures.



Warning

Punctured tyres must be renewed. Replace with tyres of the original brand and type. Be sure to tighten the valve dust caps securely to prevent leaks while riding. Never fit tyres with inner tubes, as these can cause the tyre to burst suddenly, with possibly serious consequences for the rider and passenger.

After renewing a tyre, the wheel must be balanced.



Important

Do not remove or alter the position of the wheel balancing weights.



Note

Have the tyres replaced at a Ducati Dealer or authorised Service Centre. Correct removal and installation of the wheels is essential, as some parts of the ABS (such as sensors and phonic wheels) are mounted to the wheels and require specific adjustment.

Minimum tread depth

Measure tread depth (S) at the point where tread is most worn down;
It should not be less than 2 mm, and in any case not less than the legal limit.



Important

Visually inspect the tyres at regular intervals for cracks and cuts, especially on the side walls, and bulges or large stains that indicate internal damage. Replace them if badly damaged.
Remove any stones or other foreign bodies stuck in the tread.

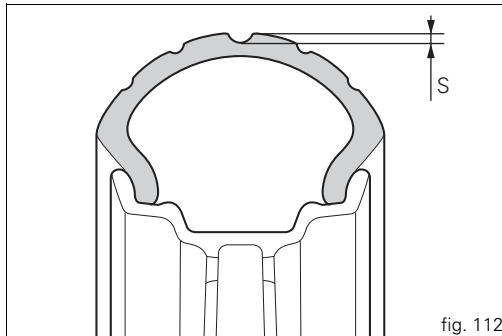

Checking the engine oil level

Check the engine oil level through the sight glass (1) on the clutch cover.

When checking oil level, the motorcycle should be perfectly upright and the engine cold.

Oil level should be between the marks near the sight glass. If the level is low, top up with SHELL Advance 4T Ultra engine oil.

Remove the oil filler cap (2) and top up until the oil reaches the required level. Replace the filler cap.

Important

Engine oil and oil filters must be changed by a Ducati Dealer or authorised Service Centre at the intervals specified in the scheduled maintenance table reported in the Warranty Booklet.

Oil viscosity

SAE 15W-50

The other viscosity degrees indicated in the table can be used if the local average temperature is within the limits of the specified range.

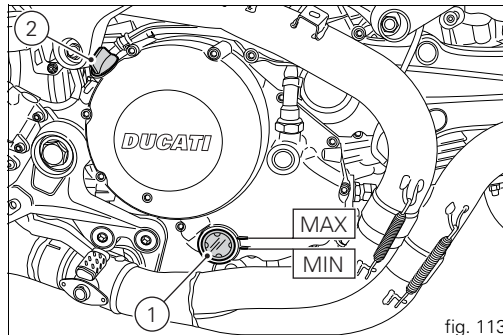
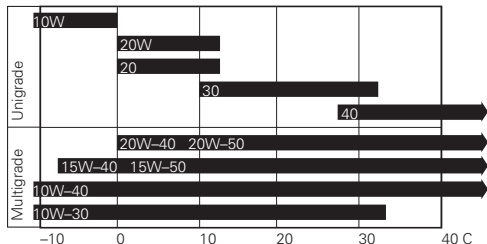

fig. 113



Cleaning and replacing the spark plugs

Spark plugs are an important part of the engine and should be checked at regular intervals.

This is a relatively simple operation and provides a good indication of how well the engine is running.

Pull the spark plug caps off the spark plugs and remove the plugs from the cylinder heads using the wrench supplied in the toolkit.

Check the colour of the ceramic insulation around the central electrode: an even brown colour is a sign that the engine is in good running order.

If the insulation is any other colour, or if there are dark deposits, replace the spark plug and describe the condition of the old plug to a Ducati dealer or Authorized Service Centre.

Also check the central electrode; if it is worn or glazed, replace the spark plug.

Check the distance between the electrodes, which must be: 0.7 - 0.8 mm.

Important

If adjustment is required, bend the side electrode carefully. A gap outside the specified limits will adversely affect engine performance and may lead to difficult starting or erratic idling.

Thoroughly clean the electrode and insulation using a wire brush, and check the condition of the gasket.

Carefully clean the seat in the cylinder head and be careful not to let any foreign material fall into the combustion chamber.

Insert the spark plug in the cylinder head and screw in fully by hand. Tighten to a torque of 20 Nm.

If you do not have a torque wrench, after hand-tightening the spark plug, turn it an additional half turn with the wrench provided in the tool kit.



Important

Do not use spark plugs with an unsuitable heat rating or incorrect reach.

The spark plug must be tightened correctly.

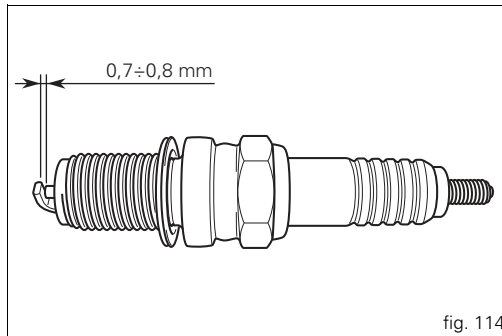

fig. 114

General cleaning

To preserve the original shine on metal surfaces and paintwork, wash and clean your motorcycle at regular intervals depending on the type of use and according to the particular road conditions. Use specific products, where possible biodegradable. Avoid aggressive detergents or solvents.

Only use water and neutral soap to clean the Plexiglas and the seat.

Clean the aluminium components regularly and by hand. Use specific detergents for aluminium that do NOT contain abrasive substances or caustic soda.



Note

Do not use abrasive or steel wool sponges, use only a soft cloth.

The warranty does not apply to motorcycles where there is evidence of poor maintenance.



Important

Do not wash your motorcycle immediately after use, as marks can form due to evaporation of the water on hot surfaces.

Never clean the motorcycle using hot or high-pressure water jets.

Cleaning the motorcycle with a high pressure water jet may lead to seizure or serious faults in the front fork, wheel hub assembly, electric system, headlight (fogging), front fork seals, air inlets or exhaust silencers, with consequent loss of safety.

If parts of the engine are unusually dirty or greasy, use a degreasing agent, avoiding contact with transmission components (chain, front and rear sprockets, etc.).

Rinse with warm water and dry all surfaces with chamois leather.



Warning

There may be loss of braking efficiency immediately after washing the motorcycle. Never grease or lubricate the brake discs as this would cause loss of braking effectiveness.

Clean the discs with an oil-free solvent.



Warning

The headlight might fog up due to washing, rain or moisture.

Switch headlight on for a short time to dry up any condensate.

Carefully clean the phonic wheels of the ABS so to ensure system efficiency. Do not use aggressive products so to avoid damaging the phonic wheels and the sensors.

Storing the motorcycle

If the motorcycle is to be left unused for a long period, it is advisable to carry out the following operations first:

clean the motorcycle;

empty the fuel tank;

pour a few drops of engine oil into the cylinders through the spark plug bores, then turn the engine over by hand a few times to form a protective film of oil on the inner walls of the cylinder;

place the motorcycle on the service stand;

disconnect and remove the battery. If the motorcycle has been left unused for more than a month, the battery should be checked and re-charged if necessary.

Protect the motorcycle with a specific motorcycle cover that will not damage the paintwork or retain moisture.

This type of motorcycle cover is available from Ducati Performance.

Important notes

The legislation in some countries (France, Germany, Great Britain, Switzerland, etc.) sets certain noise and pollution standards.

Periodically carry out the required checks and renew parts as necessary, using Ducati original spare parts, in compliance with the regulations in the country concerned.

Maintenance

Programmed maintenance plan: operations to be carried out by the dealer

List of operations and type of intervention [set mileage (km/mi) or time interval *]	Km. x1000	1	12	24	36	48	60
	mi. x1000	0.6	7.5	15	22.5	30	37.5
	Months	6	12	24	36	48	60
Change the engine oil		●	●	●	●	●	●
Change the engine oil filter		●	●	●	●	●	●
Clean the engine oil pick-up filter					●		
Check the engine oil pressure				●		●	
Check/adjust the valve clearances (1)			●	●	●	●	●
Check the tension of the timing belts (1)			●		●		●
Renew the timing belts				●		●	
Check and clean the spark plugs. Renew if necessary				●		●	
Check and clean the air filter (1)			●		●		●

List of operations and type of intervention [set mileage (km/mi) or time interval *]	Km. x1000	1	12	24	36	48	60
	mi. x1000	0.6	7.5	15	22.5	30	37.5
	Months	6	12	24	36	48	60
Change the air filter				●		●	
Check throttle body synchronisation and idle speed setting (1)			●	●	●	●	●
Check the brake and clutch fluid levels		●	●	●	●	●	●
Change the clutch and brake fluid					●		
Check and adjust the brake and clutch control cables			●	●	●	●	●
Check/lubricate the throttle/choke cables			●	●	●	●	●
Check tyre pressure and wear		●	●	●	●	●	●
Check the brake pads. Renew if necessary		●	●	●	●	●	●
Check the steering head bearings				●		●	
Check the drive chain tension, alignment and lubrication		●	●	●	●	●	●
Check the clutch disc pack. Renew if necessary (1)			●	●	●	●	●
Check the rear wheel cush drive				●		●	
Check the wheel hub bearings				●		●	
Check the indicators and lighting			●	●	●	●	●
Check tightness of nuts and screw securing the engine to the frame			●	●	●	●	●
Check the sidestand			●	●	●	●	●
Check tightness of the front wheel axle nut			●	●	●	●	●
Check tightness of the rear wheel axle nut			●	●	●	●	●
Check the external fuel hoses			●	●	●	●	●

List of operations and type of intervention [set mileage (km/mi) or time interval *]	Km. x1000	1	12	24	36	48	60
	mi. x1000	0.6	7.5	15	22.5	30	37.5
	Months	6	12	24	36	48	60
Change the front fork oil					●		
Check the forks and rear shock absorber for oil leaks			●	●	●	●	●
Check the front sprocket retaining bolts			●	●	●	●	●
General lubrication and greasing			●	●	●	●	●
Check and recharge the battery			●	●	●	●	●
Road test the motorcycle		●	●	●	●	●	●
General cleaning			●	●	●	●	●

* Service operation to be carried out in accordance with the specified distance or time intervals (km or months), whichever occurs first.

(1) Operation to be performed only if set distance interval is reached

Programmed maintenance plan: operations to be carried out by the customer

List of operations and type of intervention [set mileage (km/mi) or time interval *]	Km. x1000	1
	mi. x1000	0.6
	Months	6
Checking the engine oil level		●
Check the brake and clutch fluid levels		●
Check tyre pressure and wear		●
Check the drive chain tension and lubrication		●
Check the brake pads. If necessary, contact your dealer to renew pads		●

* Service operation to be carried out in accordance with the specified distance or time intervals (km or months), whichever occurs first.

Technical data

Overall dimensions (mm)

Weights

Dry weight in running order without fluids and battery:
169 kg.

Dry weight in running order without fuel:
179 kg.
Fully laden: 390 kg



Warning

Failure to observe weight limits could result in poor handling and impair the performance of your motorcycle, and could result in loss of control.

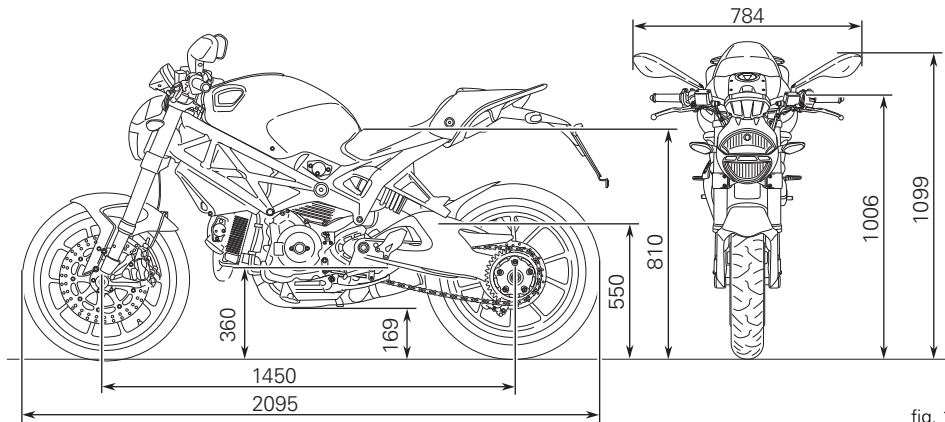

fig. 115

FUEL, LUBRICANTS AND OTHER FLUIDS	TYPE	CU DM (LITRES)
Fuel tank, including a reserve of 3.5 dm ³ (litres)	Unleaded fuel with RON 95 fuel octane rating (at least). For USA version use unleaded fuel with at least 90 fuel octane (RON+MON)/2.	13.5
Sump and filter	SHELL - Advance 4T Ultra	3.8
Front/rear brake and clutch circuits	SHELL Advance Brake DOT 4	—
Protection for electrical contacts	SHELL Advance Contact Cleaner	—
Front fork	SHELL Advance Fork 7.5 or Donax TA	445 cc, for leg



Important

Do not use additives in fuel or lubricants.

Engine

Longitudinal 90° "L" twin cylinder, four-stroke.

Bore (mm):

98

Stroke (mm):

71.5

Total displacement cm³:

1079

Compression ratio:

11.3 ± 0.5:1

Max power at crankshaft (95/1/EC):

73.5 kW/- 100 HP at 7,500 rpm

Max torque at crankshaft (95/1/EC):

103 Nm - 10.5 Kgm at 6,000 rpm.

Timing system

DESMODROMIC (type) with two valves per cylinder, operated by four rockers (2 opening rockers and 2 closing rockers) and one overhead camshaft. It is operated by the crankshaft through spur gears, belt rollers and toothed belts.

Desmodromic timing system (fig. 116)

- 1) Opening (or upper) rocker.
- 2) Opening rocker shim.
- 3) Split rings.
- 4) Closing (or lower) rocker shim.
- 5) Return spring for lower rocker.
- 6) Closing (or lower) rocker.
- 7) Camshaft.
- 8) Valve.

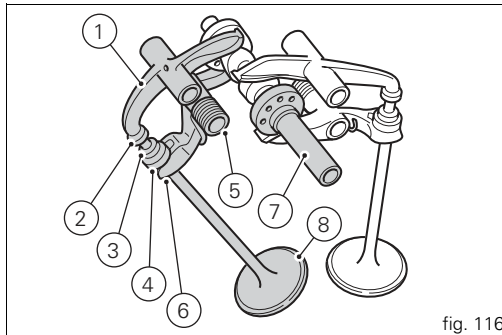

fig. 116

Performance data

Maximum speed in any gear should be reached only after the correct running-in period with the motorcycle properly serviced at the recommended intervals.



Important

Failure to follow these instructions will release Ducati Motor Holding S.p.A. from any liability for any engine damage or shortened engine life.

Spark plugs

Make:

NGK

Type:

DCPR8E.

Fuel system

SIEMENS indirect electronic injection.

Throttle body diameter:

45 mm

Injectors per cylinder: 1

Holes per injector: 8

Fuel supply: 95-98 RON.



Warning (USA version)

Use a min. number of 90 octane (RON+MON)/2.

Brakes

Separate-action anti-lock brake system operated by hall-type sensors mounted to each wheel with phonic wheel detection: ABS can be disabled.

Front

Type:
with drilled steel disc.
2 discs.

Disc diameter:
320 mm.

Hydraulically operated by a control lever on right handlebar.
Differential bore brake callipers.

Make and type:
BREMBO P4.32 K 4 pistons.

Friction material:
FERIT I/D 450 FF.

Master cylinder type:
PR 18/19.

master cylinder Ø: 18 mm.

Rear

Type:
with fixed drilled steel disc.

Disc diameter:
245 mm.

Hydraulically operated by pedal on right side.

Brake caliper:
34 mm Ø piston.

Make and type:

P 34 C

Friction material:
FERIT I/D 450 FF.

Master cylinder type:
PS 11.

master cylinder Ø: 11 mm.



Warning

Brake fluid can dissolve paintwork and can cause severe eye and skin injuries in the event of accidental spilling. Wash the affected area with abundant running water.

Transmission

Wet clutch controlled by the lever on left-hand side of the handlebar.

Transmission from engine to gearbox input shaft via spur gears.

Front sprocket/clutch sprocket ratio:

33/61

Gearbox:

6-speed;

with constant mesh gears, gearchange pedal on left.

Final drive ratio:

15/39

Total gear ratios:

1st gear 15/37

2nd gear 17/30

3rd gear 20/27

4th gear 22/24

5th gear 24/23

6th gear 28/24

Drive transmitted from gearbox to rear wheel via chain:

Make:

REGINA

Type:

525 ZRPK

Dimensions:

5/8" x 1/4"

No. of links:

104



Important

The above gear ratios are approved and should not be modified under any circumstances.

However, if you wish to tune up your motorcycle for competitions or special tracks, Ducati Motor Holding S.p.A. will be pleased to provide information about the special ratios available. please contact a Ducati Dealer or Authorised Service Centre.



Warning

If the rear sprocket needs replacing, contact a Ducati Dealer or authorised Service Center.

Incorrect replacement of this component could seriously endanger rider and passenger safety and cause irreparable damage to the motorcycle.

Frame

Chromium-molybdenum tubular trellis frame, cast aluminium rear subframe

Steering angle (on each side):

32°

Steering head angle:

24°

Trail mm:

87

Wheels

Ten Y-spokes, light-alloy rims.

Front

Dimensions:

MT3.50x17"

Rear

Dimensions:

MT5.50x17"

Both wheels have removable axles.

Tyres

Front

Radial tubeless tyre.

Size:

120/70-ZR17

Rear

Radial tubeless tyre.

Size:

180/55-ZR17

Suspension

Front

Marzocchi fully-adjustable hydraulic upside-down fork:

Stanchion (leg) diameter 43 mm.

Travel along fork leg axis: 130 mm.

Rear

Sachs progressive monoshock with adjustable rebound and spring preload:

Shock absorber stroke:

59.5 mm.

Rear wheel travel: 148 mm.



Note

Do not carry out any operations on the motorcycle that could modify the technical characteristics for which approval was obtained.

Exhaust system

Equipped with catalytic converter.

Colour schemes

1100 EVO ABS

Ducati Anniversary red part no. 473.1010 (PPG), White Band;
Clear lacquer, code 228.880 (PPG);
Red frame and black wheel rims.

Diamond Black code 57E22714 (AKZO), Racing Grey band;
Enamel code 54M22705 (AKZO);
Clear lacquer, code 228.880 (PPG);
Racing Grey frame and black wheel rims.

Electric system

The main components of the electric system are:

HEADLIGHT:

low beam: H7 (12 V-55 W).

high beam: H7 (12 V-55 W).

parking light: LED 13.5V 3.2W/0.1W.

Electrical controls on handlebars:

Turn signals:

bulb type: 12V-10W.

Horn.

Brake light switches.

Battery, 12 V-10 Ah.

Generator, 12 V-360 W.

ELECTRONIC VOLTAGE REGULATOR, protected with a
30 A fuse located to the side of the control unit (10, fig. 118).

Starter motor, 12 V-0.7 kW.

Tail light and brake signal:

LED.

Number plate light:

bulb type: C5W (12 V-5 W).



Note

To replace the bulbs, refer to the paragraph "Changing bulbs" on page 111.

Fuses

The electric system components are protected by eight fuses located in the fusebox. Only six fuses are connected to the system, two are spares.

Refer to the table below to identify the circuits protected by the various fuses and their ratings.

KEY TO THE FUSEBOX

Pos.	El. item	Rating
1	Key ON	10 A
2	Side lights, high/low beam	15 A
3	El. item	15 A
4	Instrument panel	5 A
5	Injection	20 A
6	ECU	5 A
7	Spare	20 A
8	Spare	15 A

The main fuse box (9) is located on the right side of the frame.

Remove the protective cover (A) to access the fuses.

In addition to the fuse box, the two ABS fuses (10) are located near the regulator fuse.

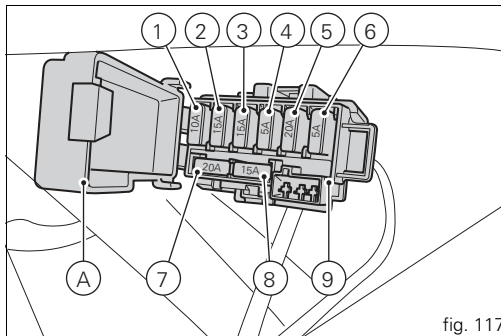

fig. 117

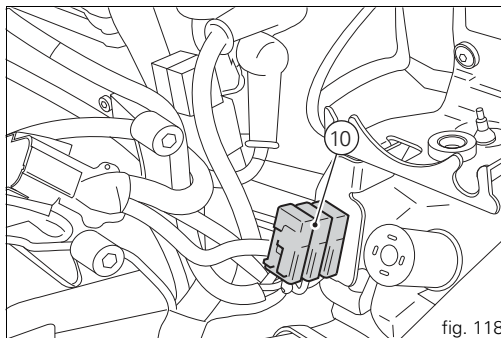

fig. 118

A blown fuse is identified by a broken filament (11, fig. 119).

Important

Switch the ignition key to OFF before replacing the fuse to avoid possible short-circuits.

Warning

Never use a fuse with a rating other than that specified. Failure to observe this rule may damage the electric system or even cause fire.

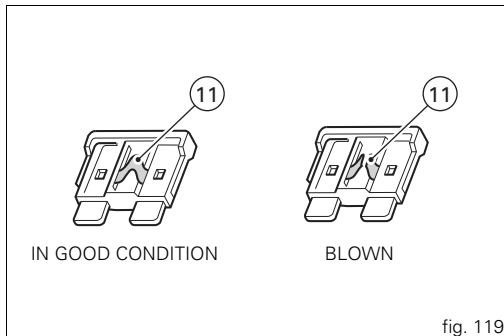

Ignition /electric system diagram key

- 1) Right-hand handlebar switch
- 2) Ignition switch
- 3) Horizontal cylinder spark plug
- 4) Vertical cylinder spark plug
- 5) Starter motor
- 6) Solenoid starter
- 7) Battery
- 8) Main fuse
- 9) Regulator
- 10) Generator
- 11) RH rear turn indicator
- 12) Tail light
- 13) Number plate light
- 14) LH rear turn indicator
- 15) Fuel tank
- 16) Horizontal cylinder exhaust lambda sensor
- 17) Injection relay
- 18) Self-diagnosis/DDA
- 19) Horizontal cylinder coil
- 20) Vertical cylinder coil
- 21) Headlight
- 22) MAP sensor
- 23) Horizontal cylinder injector
- 24) Vertical cylinder injector
- 25) Throttle position sensor
- 26) Timing/rpm sensor
- 27) Cylinder temperature sensor
- 28) Rear speed sensor
- 29) Side stand
- 30) Horn
- 31) Neutral switch
- 32) Oil pressure switch
- 33) Rear stop switch
- 34) ECU
- 35) Fuses
- 36) Clutch switch
- 37) Front stop switch
- 38) Left-hand handlebar switch
- 39) Transponder antenna
- 40) Air temperature sensor
- 41) Vertical cylinder exhaust lambda sensor
- 42) Instrument panel
- 43) Light relay
- 44) LH front turn indicator
- 45) RH front turn indicator
- 46) Valve motor
- 47) Stepper motor
- 48) ABS fuses
- 49) ABS ECU
- 50) Front speed sensor
- 51) DTC

Wire colour code

B Blue
W White
V Violet
Bk Black
Y Yellow
R Red
Lb Light blue
Gr Grey E
G Green
Bn Brown
O Orange
P Pink



Note

The electric system wiring diagram is at the end of this manual.

Routine maintenance record

KM	DUCATI SERVICE	MILEAGE	DATE
1000			
12000			
24000			
36000			
48000			
60000			

For United States of America Version Only

Reporting of safety defects

If you believe that your vehicle has a defect which could cause a crash or could cause injury or death, you should immediately inform the National Highway Traffic Safety Administration (NHTSA) in addition to notifying Ducati North America. If NHTSA receives similar complaints, it may open an investigation, and if it finds that a safety defect exists in a group of vehicles, it may order a recall and remedy campaign. However, NHTSA cannot become involved in individual problems between you, your dealer, or Ducati North America. To contact NHTSA, you may either call the Auto Safety Hotline toll-free at 1-800-424-9393 (or 366-0123 in Washington, D.C. area) or write to: NHTSA, 1200 New Jersey Avenue SE W43-488, Washington, D.C. 20590. You can also obtain other information about motor vehicle safety from the Hotline.

Safety warnings

Traffic Rules vary from jurisdiction to jurisdiction. Know the regulations in your jurisdiction before riding this motorcycle.



Warning

This motorcycle is designed and intended for use on streets and other smooth, paved areas only. Do not use this motorcycle on unpaved surfaces. Such use could lead to upset or other accident.

Noise emission warranty

Ducati Motor S.p.A. warrants that this exhaust system, at the time of sale, meets all applicable U.S. EPA Federal noise standards. This warranty extends to the first person who buys this exhaust system for purposes other than resale, and to all subsequent buyers. Warranty claims should be directed to: Ducati North America, Inc., 10443 Bandley Drive, Cupertino, California, 95014
Tel: 001.408.253.0499 - Fax: 001.408.253.4099

Noise and exhaust emission control system information

Source of Emissions

The combustion process produces carbon monoxide and hydrocarbons. Control of hydrocarbons is very important because under certain conditions, they react to form photochemical smog when subjected to sunlight. Carbon monoxide does not react in the same way, but is toxic. Ducati utilizes lean carburetor settings and other systems to reduce carbon monoxide and hydrocarbons.

Exhaust Emission Control System

The Exhaust Emission Control System is composed of lean carburetor settings, and no adjustments should be made except idle speed adjustments with the throttle stop screw. The Exhaust Emission Control System is separate from the crankcase emission control system.

Crankcase Emission Control System

The engine is equipped with a closed crankcase system to prevent discharging crankcase emissions into the atmosphere. Blow-by gas is returned to the combustion chamber through the air cleaner and the throttle body.

Evaporative Emission Control System

California motorcycles are equipped with an evaporative emission control system which consists of a charcoal canister and associated piping. This system prevents the escape of fuel vapors from the throttle body and fuel tank.

Tampering warning

Tampering with Noise Control System Prohibited. Federal Law prohibits the following acts or causing thereof:

(1) the removal or rendering inoperative by any person, other than for purposes of maintenance, repair, or replacement, of any device or element of design incorporated into any new vehicle for the purpose of noise control prior to its sale or delivery to the ultimate purchaser or while it is in use; or (2) the use of the vehicle after such device or element of design has been removed or rendered inoperative by any person.

Among those acts presumed to constitute tampering are the acts listed below:

- (1) Removal of, or puncturing the muffler, baffles, header pipes or any other component which conducts exhaust gases.
 - (2) Removal or puncturing of any part of the intake system.
 - (3) Lack of proper maintenance.
 - (4) Replacing any moving part of the vehicle, or parts of the exhaust or intake system, with parts other than those specified by the manufacturer.
- This product should be checked for repair or replacement if the motorcycle noise has increased significantly through use. Otherwise, the owner may become subject to penalties under state and local ordinances.

Problems that may affect motorcycle emissions

If you are aware of any of the following symptoms, have the vehicle inspected and repaired by your local Ducati dealer.

Symptoms:

- Hard starting or stalling after starting.
- Rough idle.
- Misfiring or backfiring during acceleration.
- After-burning (backfiring).
- Poor performance (driveability) and poor economy.

Riding safety

The points given below are applicable for every day motorcycle use and should be carefully observed for safe and effective vehicle operation.

A motorcycle does not provide the impact protection of an automobile, so defensive riding in addition to wearing protective apparel is extremely important.

Do not let protective apparel give you a false sense of security.

Before changing lanes, look over your shoulder to make sure the way is clear. Do not rely solely on the rear view mirror; you may misjudge a vehicle's distance and speed, or you may not see it at all.

When going up steep slopes, shift to a lower gear so that there is plenty of power to spare rather than overloading the engine.

When applying the brakes, use both the front and rear brakes. Applying only one brake for sudden braking may cause the motorcycle to skid and lose control.

When going down long slopes, control vehicle speed by closing the throttle. Use the front and rear brakes for auxiliary braking.

Riding at the proper rate of speed and avoiding unnecessarily fast acceleration are important not only for safety and low fuel consumption but also for long vehicle life and quieter operation.

When riding in wet conditions or on loose roadway surfaces, the ability to maneuver will be reduced. All of your actions should be smooth under these conditions. Sudden acceleration, braking or turning may cause loss of control.

When the roadway is wet, rely more on the throttle to control vehicle speed and less on the front and rear brakes.

The throttle should also be used judiciously to avoid skidding the rear wheel from too rapid acceleration or deceleration. On rough roads, exercise caution, slow down, and grip the fuel tank with your knees for better stability.

When quick acceleration is necessary as in passing, shift to a lower gear to obtain the necessary power.

Do not down shift at too high an r.p.m. to avoid damage to the engine from overrevving.

Avoiding unnecessary weaving is important to the safety of both the rider and other motorists.

Do not exceed the legal speed limit or drive too fast for existing conditions. High speed increases the influence of any condition affecting stability and the loss of control.

Operate motorcycle only at moderate speed and out of traffic until you have become thoroughly familiar with its operation and handling characteristics under all conditions. This is a very high performance motorcycle, designed and intended for use by experienced careful riders only!

A new motorcycle must be operated according to a special break-in procedure (see Running in recommendations).



Warning

Before starting engine, check for proper operation of brake, clutch, shifter, throttle controls, correct fuel and oil supply.

Gasoline is extremely flammable and is explosive under certain conditions. Refuell in a well ventilated area with the engine stopped. Do not smoke or allow open flames or sparks when refuelling or servicing the fuel system. Always close the fuel petcock when the engine is not running to prevent flooding of the throttle body. Do not overfill fuel tank (see instructions page 40).

Motorcycle exhaust contains poisonous carbon monoxide gas. Do not inhale exhaust gases and never run the engine in a closed garage or confined area.

Use only Ducati approved parts and accessories.

This motorcycle was not intended to be equipped with a sidecar or to be used to tow any trailer or other vehicle. Ducati does not manufacture sidecars or trailers and cannot predict the effects of such accessories on handling or stability, but can only warn that the effects will be adverse and any damage to motorcycle components caused by the use of such accessories will not be remedied under warranty.



Warning

Do not ride the motorcycle with helmets attached to the hook; the helmets could cause an accident by distracting the operator or interfering with normal vehicle operation.

Protective apparel

Always wear a helmet. Most motorcycle accident fatalities are due to head injuries.

For safety eye protection, gloves, and high top, sturdy boots should also be worn.

The exhaust system becomes very hot during operation, never touch the exhaust system. Wear clothing that fully covers your legs. Do not wear loose clothing which could catch on the control levers, footrests, wheels, or chain. Any amount of alcohol will significantly interfere with your ability to safely operate your motorcycle. Don't drink and ride.

Vehicle identification number (VIN)

Every Ducati motorcycle is identified by two identification numbers (see page 10). Figure A specifically shows the frame identification numbers.

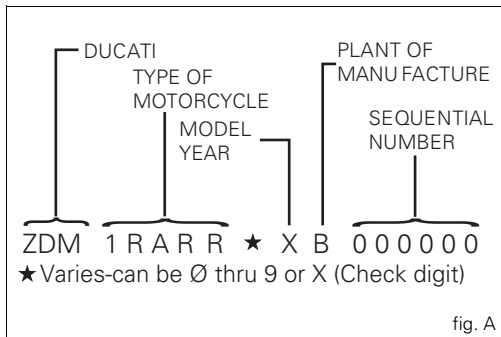

fig. A

Label location (fig. B)

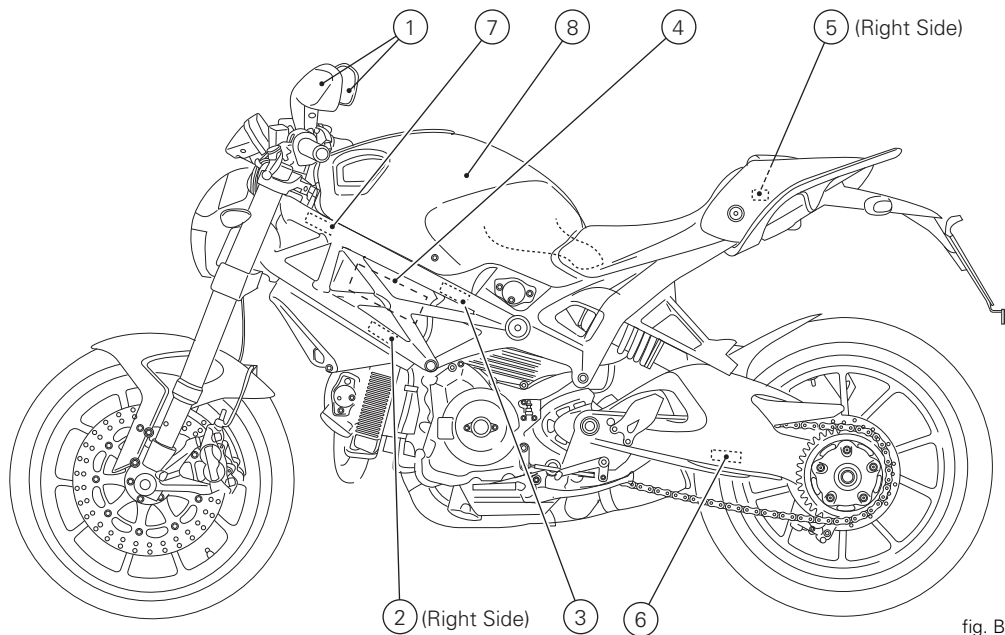

fig. B

California emission control warranty statement

Your warranty rights and obligations

The California Air Resources Board is pleased to explain the emission control system warranty on your MY 2012 motorcycle. In California, new motor vehicles must be designated, built and equipped to meet the State's stringent anti-smog standards. Ducati North America, Inc. must warrant the emission control system on your motorcycle for the periods of time listed below provided there has been no abuse, neglect or improper maintenance of your motorcycle. Your emission control system may include parts such as fuel-injection system, the ignition system, catalytic converter, and engine computer. Also included may be hoses, belts, connectors and other emission-related assemblies. Where a warrantable condition exists, Ducati North America, Inc. will repair your motorcycle at no cost to you including diagnosis, parts and labor.

Manufacturer's warranty coverage

- 5 years or 30,000 kilometers (18641 miles), whichever first occurs.

Owner's warranty responsibilities:

- As the motorcycle owner, you are responsible for the performance of the required maintenance listed in your owner's manual. Ducati North America, Inc. recommends that you retain all receipts covering maintenance on your motorcycle, but Ducati North America, Inc. cannot deny warranty solely for the lack of receipts or for your failure to ensure the performance of all scheduled maintenance.
- You are responsible for presenting your motorcycle to a Ducati dealer as soon as a problem exists. The warranty repairs should be completed in a reasonable amount of time, not to exceed 30 days.
- As the motorcycle owner, you should also be aware that Ducati North America, Inc. may deny you warranty coverage if your motorcycle or a part has failed due to abuse, neglect, improper maintenance or unapproved modifications.

If you have any questions regarding your warranty rights and responsibilities, you should contact Ducati North America, Inc. at 001.408.253.0499 or the California Air Resource Board at 9528 Telstar Avenue, El Monte, CA 91731.

California evaporation emission system (fig. C)



Important

In the event of fuel system malfunction, contact Ducati's authorized Service Centres.

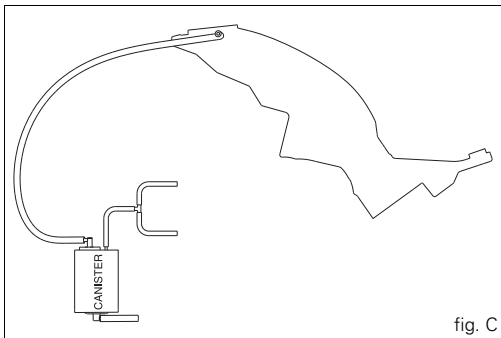

fig. C

Ducati limited warranty on emission control system

Ducati North America, Inc., 10443 Bandle Drive Cupertino, California, 95014 warrants that each new 1998 and later Ducati motorcycle, that includes as standard equipment a headlight, tail-light and stoplight, and is street legal:

A) is designed, built and equipped so as to conform at the time of initial retail purchase with all applicable regulations of the United States Environmental Protection Agency, and the California Air Resources Board; and
B) is free from defects in material and workmanship which cause such motorcycle to fail to conform with applicable regulations of the United States Environmental Protection Agency or the California Air Resources Board for a period of use of 30,000 kilometers (18,641 miles), or 5 (five) years from the date of initial retail delivery, whichever first occurs.

I. Coverage

Warranty defects shall be remedied during customary business hours at any authorized Ducati motorcycle dealer located within the United States of America in compliance with the Clean Air Act and applicable regulations of the United States Environmental Protection Agency and the California Air Resources Board. Any part or parts replaced under this warranty shall become the property of Ducati. In the state of California only, emissions related warranted parts are specifically defined by that state's Emissions Warranty Parts List. These warranted parts are: carburetor and internal parts; intake manifold; fuel tank, fuel injection system; spark advance mechanism; crankcase breather; air cutoff valves; fuel tank cap for evaporative emission

controlled vehicles; oil filler cap; pressure control valve; fuel/vapor separator; canister; igniters; breaker governors; ignition coils; ignition wires; ignition points, condensers, and spark plugs if failure occurs prior to the first scheduled replacement, and hoses, clamps, fittings and tubing used directly in these parts. Since emission related parts may vary from model to model, certain models may not contain all of these parts and certain models may contain functionally equivalent parts.

In the state of California only, Emission Control System emergency repairs, as provided for in the California Administrative Code, may be performed by other than an authorized Ducati dealer. An emergency situation occurs when an authorized Ducati dealer is not reasonably available, a part is not available within 30 days, or a repair is not complete within 30 days. Any replacement part can be used in an emergency repair. Ducati will reimburse the owner for the expenses, including diagnosis, not to exceed Ducati's suggested retail price for all warranted parts replaced and labor charges based on Ducati's recommended time allowance for the warranty repair and the geographically appropriate hourly labor rate. The owner may be required to keep receipts and failed parts in order to receive compensation.

II. Limitations

This Emission Control System Warranty shall not cover any of the following:

- A. Repair or replacement required as a result of
 - (1) accident,
 - (2) misuse,
 - (3) repairs improperly performed or replacements improperly installed,
 - (4) use of replacement parts or accessories not conforming to Ducati specifications which adversely affect performance and/or
 - (5) use in competitive racing or related events.
- B. Inspections, replacement of parts and other services and adjustments required for routine maintenance.
- C. Any motorcycle on which odometer mileage has been changed so that actual mileage cannot be readily determined.

III. Limited liability

- A. The liability of Ducati under this Emission Control Systems Warranty is limited solely to the remedying of defects in material or workmanship by an authorized Ducati motorcycle dealer at its place of business during customary business hours. This warranty does not cover inconvenience or loss of use of the motorcycle or transportation of the motorcycle to or from the Ducati dealer. Ducati shall not be liable for any other expenses, loss or damage, whether direct, incidental, consequential or exemplary arising in connection with the sale or use of or inability to use the Ducati motorcycle for any purpose. Some states do not allow the exclusion or

limitation of any incidental or consequential damages, so the above limitations may not apply to you.

B. No express emission control system warranty is given by Ducati except as specifically set forth herein. Any emission control system warranty implied by law, including any warranty of merchantability or fitness for a particular purpose, is limited to the express emission control systems warranty terms stated in this warranty. The foregoing statements of warranty are exclusive and in lieu of all other remedies. Some states do not allow limitations on how long an implied warranty lasts so the above limitation may not apply to you.

C. No dealer is authorized to modify this Ducati Limited Emission Control Systems Warranty.

IV. Legal rights

This warranty gives you specific legal rights, and you may also have other rights which vary from state to state.

V. This warranty is in addition to the Ducati limited motorcycle warranty.

VI. Additional information

Any replacement part that is equivalent in performance and durability may be used in the performance of any maintenance or repairs. However, Ducati is not liable for these parts. The owner is responsible for the performance of all required maintenance. Such maintenance may be performed at a service establishment or by any individual. The warranty period begins on the date the motorcycle is delivered to an ultimate purchaser.

Ducati North America, Inc.
10443 Bandle Drive
Cupertino, California, 95014
Tel: 001.408.253.0499
Fax: 001.408.253.4099
E-mail: customerservice@ducatiusa.com
Web site: www.ducatiusa.com

Routine Maintenance Record

KM	MI	DUCATI SERVICE NAME	MILEAGE	DATE
1,000	600			
12,000	7,500			
24,000	15,000			
36,000	22,500			
48,000	30,000			
60,000	37,500			

Stampato 11/2011

Cod. 913.7.167.1E

Ducati Motor Holding spa
ducati.com

Via Cavalieri Ducati, 3
40132 Bologna, Italia
Tel. +39 051 6413111
Fax +39 051 406580

cod 913.7.167.1E