

Owner's manual

HYPERMOTARD

HYPERMOTARD SP



Owner's manual

ENGLISH

HYPERMOTARD

HYPERMOTARD SP

This manual forms an integral part of the motorcycle and must be kept with it its whole service life.

If the motorcycle is resold, the manual must always be handed over to the new owner.

This manual must be preserved with care. If it lost or becomes damaged, contact a Ducati Dealer or authorised Service Centre without delay to obtain a new copy of the manual.

The quality standards and safety of Ducati motorcycles are steadily improved as new design solutions, equipment and accessories are developed. While the information contained in this manual is current at the time of going to print, Ducati Motor Holding S.p.A. reserves the right to make changes at any time without notice and without any obligations. For this reason, the illustrations in this manual might differ from your motorcycle.

Any and all reproduction or spreading of the contents herein in whole or in part is forbidden. All rights reserved to Ducati Motor Holding S.p.A. Any request for written authorisation to do so shall be addressed to this company, specifying the reasons for request.

Enjoy your ride!

Table of contents

Foreword	7
Safety guidelines	7
Safety alerts	8
Permitted use	9
Rider's obligations	9
Rider training	10
Riding gear	10
Best practices for motorcycle safety	12
Refuelling	14
Carrying the maximum load allowed	15
Information about carrying capacity	15
Dangerous products - warnings	16
Vehicle identification number	18
Engine identification number	19
Instrument panel (Dashboard)	20

Instrument panel	20
Technological Dictionary	23
Function push-buttons	25
LCD - Main functions	26
LCD – Parameter setting/display	27
Vehicle speed indicator	30
Engine rpm indicator (RPM)	31
Menu 1 functions	32
Menu 1 functions: Odometer (TOT)	33
Menu 1 functions: Trip meter (TRIP 1)	34
Menu 1 functions: Trip meter (TRIP 2)	35
Menu 1 functions: Partial fuel reserve counter (TRIP FUEL)	36
Menu 1 functions: Average fuel consumption indicator (CONS. AVG)	37
Menu 1 functions: Instantaneous fuel consumption indicator (CONS.)	38
Menu 1 functions: Average speed indicator (SPEED AVG)	39
Menu 1 functions: Trip time indicator (TIME TRIP)	40
Menu 2 functions	41
Menu 2 functions: Coolant temperature	42
Menu 2 functions: Air temperature (AIR)	44
Menu 2 functions: Clock	45
SET UP - Riding Style set indication	46

SERVICE function - Maintenance interventions	47	The Immobilizer system	104
Active / not active ERRORS indication	50	Keys	105
Indication if the "LAP" function is active/not active	51	Entering PIN CODE function for vehicle release	106
Riding Mode SET UP function (riding style change)	52	Operation	109
Error display function (ERRORS)	55	Duplicate keys	110
SETTING MENU	60	Light control	111
Customising Riding Modes (R.MODE)	62	Units of measurement modification function (UNITS)	114
DTC set up	66	Other functions	124
ABS set up	72		
ENGINE set up	76	Controls	133
ALL DEFAULT (Resetting the default parameters of all Riding Modes)	78	Position of motorcycle controls	133
DEFAULT (Resetting the default parameters of a single Riding Mode)	80	Ignition switch and steering lock	134
Dashboard backlighting setting function (B.LIGHT)	82	Left-hand switch	135
Lap time function (LAP): LAP activation/deactivation	84	Clutch lever	136
Lap time function (LAP): LAP registration	86	Right-hand switch	139
Lap time function (LAP): stored LAP display	88	Throttle twistgrip	140
Clock setting function (CLOCK)	92	Front brake lever	141
Battery voltage function (BATTERY)	94	Rear brake pedal	142
Engine rpm digital indication (RPM)	95	Gear change pedal	143
Immobilizer code (PIN CODE)	96	Adjusting the position of the gearchange and rear brake pedals	144

Main components and devices 146

- Position on the vehicle 146
- Tank filler plug 147
- Seat lock 148
- Helmet cable 150
- Side stand 151
- Adjusting the front fork 152
- Adjusting the rear shock absorber 154

Riding the motorcycle 156

- Running-in recommendations 156
- Pre-ride checks 158
- ABS device 160
- Starting the motorcycle 161
- Moving off 163
- Braking 164
- Stopping the motorcycle 166
- Parking 167
- Refuelling 168
- Tool kit and accessories 169

Main maintenance operations 170

- Check and top up the coolant level 170
- Checking brake and clutch fluid level 171

- Check brake pads for wear 173
- Charge the battery 174
- Check drive chain tension 178
- Chain lubrication 180
- Replace the headlight bulbs 181
- Replace the turn indicator bulbs 184
- Number plate light 185
- Beam setting 186
- Adjust rear-view mirrors 188
- Tubeless tyres 189
- Check engine oil level 191
- Clean and replace the spark plugs 193
- Clean the motorcycle 194
- Storing the motorcycle 195
- Important notes 195

Scheduled maintenance chart 196

- Scheduled maintenance chart: operations to be performed by the Dealer 196
- Scheduled maintenance chart: operations to be performed by the customer 199

Technical data 200

- Weights 200

Overall dimensions 201
Top-ups 202
Engine 203
Timing system 204
Performance data 205
Spark plugs 205
Fuel system 205
Brakes 205
Transmission 206
Frame 207
Wheels 207
Tyres 207
Suspensions 207
Exhaust system 207
Available colours 208
Electrical system 209

Routine maintenance record 215

Routine maintenance record 215

Foreword

Safety guidelines

We would like to welcome you among Ducati enthusiasts, and congratulate you on your excellent choice of motorcycle. We think you will ride your Ducati motorcycle for long journeys as well as short daily trips. Ducati Motor Holding S.p.A. wishes you smooth and enjoyable riding.

Your motorcycle is the result of Ducati Motor Holding S.p.A.'s on-going research and development efforts. It is important that you preserve its quality standard by strictly observing the maintenance plan and using genuine spare parts. This manual provides instructions on minor maintenance operations. Major maintenance operations are described in the Service Manual available to Ducati Authorised Service Centres.

In your own interest, for your safety and in order to guarantee product reliability, you are strongly advised to refer to our authorised Dealers and Service Centres

for any operations listed in the scheduled maintenance chart, see page 196.

Our highly skilled staff have access to special implements and appropriate equipment required to perform any servicing job at best, and use Ducati original spare parts only as the best guarantee for full interchangeability, smooth running and long life.

All Ducati motorcycles come with a Warranty Card. The warranty does not apply to motorcycles used in racing competitions.

Tampering with or altering any components, even partially, will make the warranty null and void effective immediately. Improper or poor maintenance, using other than original spare parts or parts not expressly approved by Ducati may invalidate your warranty rights and lead to damage or loss of performance.

Your safety and that of other road users are very important. Ducati Motor Holding S.p.A. recommends that you ride responsibly.

Before using your motorcycle for the first time, read this entire manual carefully and closely follow the guidelines outlined in it. The manual provides full information on proper motorcycle operation and

maintenance. In case of any doubts, please call a Dealer or Authorised Service Centre.

The terms RIGHT and LEFT refer to the motorcycle viewed from the riding position.

Safety alerts

To alert you to potential hazards that could potentially harm you or other persons, the following safety alerts have been used:

- Safety labels on motorcycle;
- Safety messages preceded by a warning symbol and the word WARNING or IMPORTANT.

Warning

Failure to comply with these instructions may put you at risk and result in severe injury to rider or other persons or even death.

Important

Possibility of damaging the motorcycle and/or its components.

Note

Additional information concerning the job being carried out.

Permitted use

This motorcycle may be used for riding on dirt trails or for off-road riding.

Warning

This motorcycle may not be used to tow any trailers or with a side-car attached; this can lead to loss of control and result in an accident.

This motorcycle carries the rider and can carry a passenger.

Warning

The total weight of the motorcycle in running order including rider, passenger, luggage and additional accessories should not exceed 406 kg/895 lb.

Rider's obligations

All riders must hold a valid licence.

Warning

Riding without a licence is illegal and is prosecuted by law. Always make sure you have your licence with you when riding. Do not let inexperienced riders or who do not hold a valid licence use your motorcycle.

Do not ride under the influence of alcohol and/or drugs.

Warning

Riding under the influence of alcohol and/or drugs is illegal and is prosecuted by law.

Do not take prescription or other drugs before riding unless you have consulted your doctor about their side effects.

Warning

Some medications and drugs may cause drowsiness or other effects that slow down reaction time and the rider's ability to control the motorcycle, possibly leading to an accident.

Some states require vehicle insurance.



Warning

Check your state laws. Obtain insurance coverage and keep your insurance document secure with the other motorcycle documents.

To protect rider and passenger safety, some states mandate the use of a certified helmet.



Warning

Check your state laws. Riding without a helmet may be punishable by law.



Warning

Riders without helmets are more likely to suffer severe bodily injury or die if they are in an accident.



Warning

Check that your helmet complies with safety specifications, permits good vision, is the right size for your head, and carries a certification label indicating that it conforms to the standards in force in your state. Traffic laws differ from state to state. Learn about traffic laws in your state before riding and always obey them.

Rider training

Accidents are frequently due to inexperience. Driving a motorcycle is different from driving other vehicles and requires specific riding and braking techniques.



Warning

Poor training or improper operation of the vehicle can lead to loss of control, death or severe damage.

Riding gear

Riding gear is very important for safety. Unlike cars, a motorcycle offers no impact protection in an accident.

Proper riding gear includes helmet, eye protection, gloves, boots, long sleeve jacket and long pants.

- The helmet must have the requirements listed in page 9; if your helmet does not have a visor, use suitable eye wear;
- Use five-finger gloves made from leather or abrasion-resistant material;
- Riding boots or shoes must have non-slip soles and offer ankle protection;

- Jacket, pants or riding suit must be made from leather or abrasion-resistant material and have high-visibility colours and inserts;



Important

Never wear loose clothing, items or accessories that may become tangled in motorcycle parts.



Important

For your safety, always wear proper protective gear, regardless of season and weather.



Important

Have your passenger wear proper protective clothing.

Best practices for motorcycle safety

These few simple operations are critical to people safety and to preserving the full performance of your motorcycle. Never forget to perform them before, while and after riding.

Important

During the whole running-in period, the indications recommended in section "Riding the Motorcycle" shall be observed carefully. Failure to follow these instructions releases Ducati Motor Holding S.p.A. from any liability whatsoever for any engine damage or shorter engine life.

Warning

Before riding your motorcycle, become familiar with the controls you will need to use when riding.

Perform the checks recommended in this manual before each ride (see page 161).

Warning

Failure to carry out these checks before riding, may lead to motorcycle damage and injury to rider and/or passenger.

Warning

Start the engine outdoors or in a well ventilated area. The engine should never be started or run indoors.

Exhaust gases are poisonous and may lead to loss of consciousness or even death within a short time. Use proper body position while riding and ensure your passenger does the same.

Important

Rider must hold the handlebars with both hands **AT ALL TIMES** while riding.

Important

Both rider and passenger should keep their feet on the footpegs when the motorcycle is in motion.

Important

The passenger should always hold on to the grab handles under the seat with both hands.



Important

Be very careful when tackling road junctions, or when riding in the areas near exits from private grounds, car parks or on slip roads to access motorways.



Important

Be sure you are clearly visible and do not ride within the blind spot of vehicles ahead.



Important

ALWAYS signal your intention to turn or pull to the next lane in good time using the suitable turn indicators.



Important

Park your motorcycle where no one is likely to hit it and use the side stand. Never park on uneven or soft ground or your motorcycle may fall over.



Important

Visually inspect the tyres at regular intervals for detecting cracks and cuts, especially on the side walls, bulges or large spots that are indicative of internal damage. Replace them if badly damaged. Remove any stones or other foreign bodies caught in the tread.



Warning

The engine, exhaust pipes and silencers remain hot for a long time after engine is switched off; pay particular attention not to touch exhaust system with any body part and do not park the vehicle next to inflammable material (wood, leaves etc.).



Warning

Always remove the key when you leave your motorcycle unattended and make sure it is not accessible to persons not authorised to use the motorcycle.

Refuelling

Refuel outdoors with the engine turned off.

Do not smoke or use open flames when refuelling.

Be extremely careful not to spill fuel on the engine or on the exhaust pipe.

Never fill the tank completely. Fuel should never be touching the rim of filler recess.

While refuelling, avoid inhaling fuel vapours and avoid contact with eyes, skin or clothing.



Warning

The vehicle is only compatible with fuel having a maximum content of ethanol of 10% (E10).

Using fuel with ethanol content over 10% is forbidden. Using it could result in severe damage of the engine and motorcycle components. Using fuel with ethanol content over 10% will make the warranty null and void.



Warning

In the event of illness after prolonged breathing of fuel vapours, stay outdoors and seek medical advice. In the event of contact with eyes, flush with plenty of water. After contact with skin, wash immediately with water and soap.



Warning

Fuel is highly inflammable. Clothing with spilled fuel on it should be removed as possible.

Carrying the maximum load allowed

Your motorcycle is designed for long-distance riding, carrying the maximum load allowed in full safety. Even weight distribution is critical to preserving these safety features and avoiding trouble when performing sudden manoeuvres or riding on bumpy roads.

Warning

The maximum speed permitted with the side panniers, top case and the tank bag fitted must not exceed 180 km/h.

Warning

Do not exceed the total permitted weight for the motorcycle and pay attention to information provided below regarding load capacity.

Information about carrying capacity

Important

Arrange your luggage or heavy accessories in the lowest possible position and close to motorcycle centre.

Important

Never fix bulky or heavy objects to the handlebar or to the front mudguard as this would affect stability and cause danger.

Important

Be sure to secure the luggage to the supports provided on the motorcycle as firmly as possible. Improperly secured luggage may affect stability.

Important

Do not insert any objects you may need to carry into the gaps of the frame as these may foul moving parts.

Warning

Make sure the tyres are inflated to the proper pressure and that they are in good condition.

Please, refer to paragraph "Tyres" in page 189.

Dangerous products - warnings

Used engine oil

Warning

Prolonged or repeated contact with used engine oil may cause skin cancer. If exposed to used engine oil on a daily basis, make it a rule to wash your hands thoroughly with soap immediately after use. Keep away from children.

Brake lining debris

Never attempt to clean the brake assembly using compressed air or a dry brush.

Brake fluid

Warning

Avoid spilling brake fluid onto plastic, rubber or painted parts of the motorcycle to avoid the risk of damage. Protect these parts with a clean shop cloth before proceeding to service the motorcycle. Keep away from children.

Warning

The brake fluid used in the brake system is corrosive. In the event of accidental contact with eyes or skin, wash the affected area with abundant running water.

Coolant

Engine coolant contains ethylene glycol, which may ignite under particular conditions, producing invisible flames. Although the flames from burning ethylene glycol are not visible, they are still capable of causing severe burns.

Warning

Take care not to spill engine coolant on the exhaust system or engine parts.

These parts may be hot and ignite the coolant, which will subsequently burn with invisible flames. Coolant (ethylene glycol) is an irritant and is poisonous when ingested. Keep away from children. Never remove the radiator cap when the engine is hot. The coolant will be scalding hot and is under high pressure.

The cooling fan operates automatically: keep hands well clear and make sure your clothing does not snag on the fan.

Battery



Warning

The battery gives off explosive gases; keep it away from any source of ignition such as sparks, flames and cigarettes. Charge the battery in a well-ventilated area.

Vehicle identification number



Note

These numbers identify the motorcycle model and should always be indicated when ordering spare parts.

It is recommended to record the frame number of your motorcycle in the space below.

Frame number

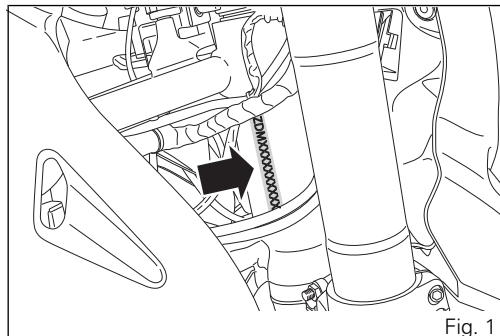

Engine identification number



Note These numbers identify the motorcycle model and should always be indicated when ordering spare parts.

It is recommended to record the number of your motorcycle's engine in the space below.

Engine number

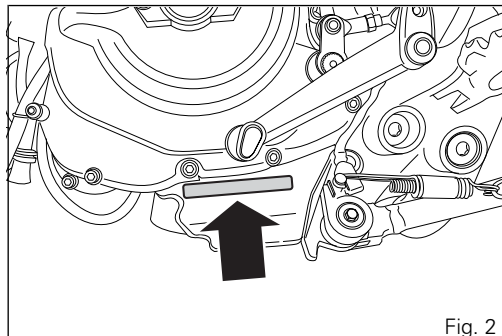

Instrument panel (Dashboard)

Instrument panel

1) LCD Dot-Matrix.

2) REV COUNTER (rpm).

Shows the engine rotation speed/minute (rpm).

3) NEUTRAL LIGHT N (GREEN).

Comes on when in neutral position.

4) HIGH BEAM LIGHT  (BLUE).

It turns on to indicate that the high beam lights are on.

5) ENGINE OIL PRESSURE LIGHT  (RED).

Comes on when engine oil pressure is too low. It must turn on at Key-On, but must turn off a few seconds after the engine has started. It may shortly come on when the engine is hot, however, it should go out as the engine revs up.

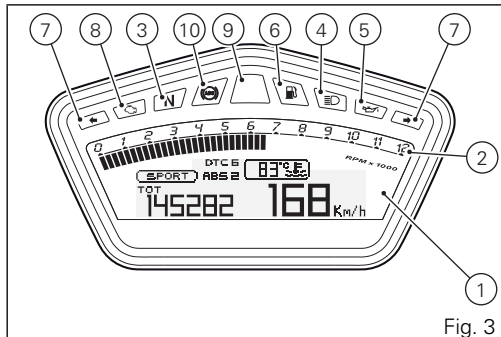

Fig. 3



Important

If ENGINE OIL light stays on, stop the engine or it may suffer severe damage.

6) LOW FUEL LIGHT  (AMBER YELLOW).

Comes on when fuel is low and there are about 4 litres of fuel left in the tank.

7) TURN INDICATOR LIGHTS  (GREEN).

Illuminates and flashes when the turn indicator is in operation. They both come on and flash when the Hazard function is in operation.

8) "ENGINE/VEHICLE DIAGNOSIS - EOBD" LIGHT  (AMBER YELLOW).

It turns on in the case of "engine" and/or "vehicle" errors and in some cases will lock the engine.

9) LIMITER LIGHT "OVER REV"/ TRACTION CONTROL LIGHT "DTC" (RED).

	Over rev light
No limiter	Off
1st threshold - no. RPM before the limiter threshold (*)	On - STEADY
Rev limiter (limiter engaged due to overrevving) (*)	On - Flashing

(*) depending on the model, each calibration of the Engine Control Unit may have a different "setting" for

the thresholds that precede the rev limiter and regarding the rev limiter itself.

	DTC intervention light
No intervention	Off
Advance cutting	On - Steady
Injection cutting	On - Steady



Note

If the Over rev function light and the DTC intervention light should both come on at the same time, the instrument panel gives priority to the Over rev function.

10) ABS LIGHT  (AMBER YELLOW).

Engine off / speed below 5 Km/h		
Light off	Light flashing	Light steady
-	ABS disabled with the menu function (**)	ABS enabled but not functioning yet
Engine on / speed below 5 Km/h		
Light off	Light flashing	Light steady
-	ABS disabled with the menu function	ABS enabled but not functioning yet
Engine on / speed above 5 Km/h		
Light off	Light flashing	Light steady
ABS enabled and functioning	ABS disabled with the menu function	ABS disabled and not functioning due to a problem

(**) The ABS should be considered actually disabled only if the light continues to flash after starting the engine.

Technological Dictionary

Acronyms and abbreviations used in the Manual

ABS
Antilock Braking System
BBS
Black Box System
CAN
Controller Area Network
DDA
DUCATI Data Acquisition
DSB
Dashboard
DTC
DUCATI Traction Control
ECU
Engine Control Unit

Riding Mode

Rider can choose, among the three different pre-set configurations (Riding Modes), the one that better suits his/her riding style or path characteristics. Riding Modes allow an immediate change of engine power and output (ENGINE), braking control levels (ABS) and traction control (DTC) intervention levels.

The available configurations are:
Sport, Touring and Urban (for Hypermotard and Hyperstrada);
Race, Sport and Wet (for Hypermotard SP).
Within every Riding Mode, the rider can customise any settings.

Ducati Traction Control (DTC)

The Ducati Traction Control system (DTC) supervises the rear wheel slipping control and settings vary through eight different levels that are programmed to offer a different tolerance level to rear wheel slipping. Each Riding Mode features a pre-set intervention level. Level eight indicates system intervention whenever a slight slipping is detected, while level one is for very expert riders because it is less sensitive to slipping and intervention is hence more rare.

Anti-lock Braking System (ABS)

Hypermotard ABS is an integral braking system with rear wheel lift-up control, ensuring both a shorter stopping distance and a higher braking stability. ABS offers three different intervention levels, one for each Riding Mode.

Ride by Wire (RbW)

The Ride by Wire system is the electronic device that controls throttle opening and closing. Throttle twistgrip and throttle body are not mechanically connected: this allows engine control unit adjusting power output by simply changing throttle opening angle.

The Ride by Wire system allows different engine powers and outputs based on the selected Riding Mode (Engine), but also serves as a control of rear wheel slipping (DTC).

Function push-buttons

1) CONTROL BUTTON

Button used to display and set instrument panel parameters with the position "▲".

2) CONTROL BUTTON

Button used to display and set instrument panel parameters with the position "▼".

3) HIGH-BEAM FLASH BUTTON FLASH

The high-beam flash button may also be used for LAP functions.

4) TURN INDICATOR CANCEL BUTTON

The turn indicators on/off button may also be used for navigating through the MENU and for activating the "Riding Mode".

Press this button for 3 seconds to the left side to activate the Hazard lights.

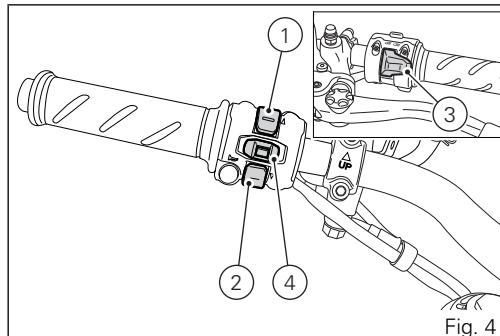

LCD - Main functions

Warning

Stop the motorcycle before using the instrument panel controls. Never operate the instrument panel controls while riding.

Data displayed on the main screen are as follows:

- 1) Engine RPM Indicator;
- 2) Vehicle Speed Indicator;
- 3) MENU 1 (Odometer, Trip 1, Trip 2, Trip Fuel, Average Consumption, Instantaneous Consumption, Average Speed and Trip Time) – UP-MAP Menu and Riding Mode Set-up Menu;
- 4) MENU 2 (Engine Coolant Temperature, Ambient Air Temperature and Clock);
- 5) Name of set Riding Mode;
- 6) Riding Mode DTC and ABS settings.

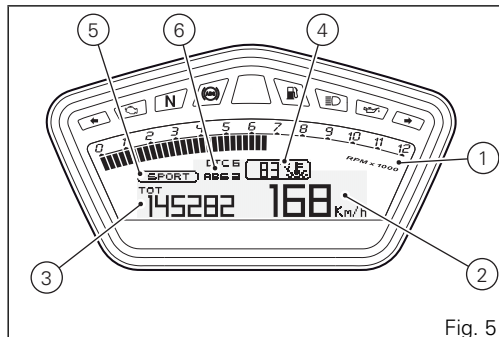

Fig. 5

Important

Never use the vehicle when the temperature reaches max. value or the engine might be damaged.

LCD – Parameter setting/display

Upon key-on, the instrument panel enables the rev counter, which increases from 0 to 11,000 and decreases going back to 0; the "DUCATI HYPERMOTARD" lettering is enabled, in a scrolling manner, on the Dot-Matrix area; warning lights come on in sequence from the outside to the inside. Once check is completed, the instrument panel always displays Odometer (TOT), engine coolant temperature and "Riding mode" functions as "main" indicators.

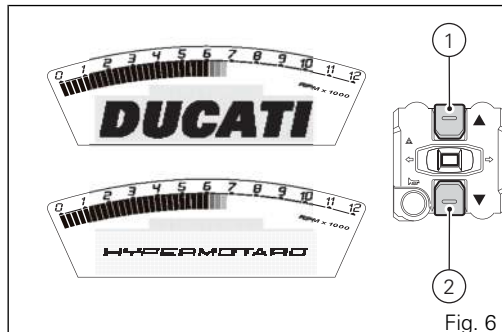

Fig. 6

If the bike has a Performance outfit, namely if it features Performance exhaust pipes (part no. 96480031A) - Performance silencer kit (part no. 96480051A), upon vehicle key-on, and during initial check, the instrument panel displays the "HYPERMOTARD PERFORMANCE" or "HYPERMOTARD RACING" indicators after the DUCATI lettering:

- HYPERMOTARD PERFORMANCE: bike is equipped with the Performance silencer kit;
- HYPERMOTARD RACING: bike is equipped with Performance complete exhaust kit.

Note

Performance exhaust kit (part no. 96480031A) and Performance silencer kit (part no. 96480051A) can be purchased at a Ducati Dealer or authorised Service Centre.

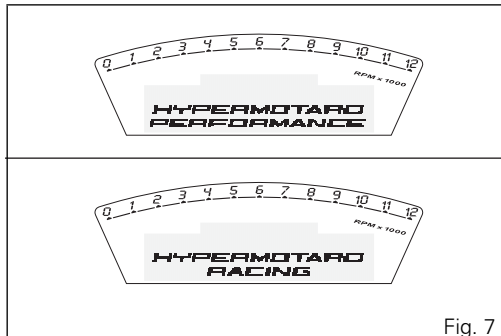

Warning

To fit Performance exhaust kit (part no. 96480031A) and Performance silencer kit (part no. 96480051A) contact a Ducati Dealer or authorised Service Centre.

Once initial check is completed, the instrument panel always goes to the "main" displaying page, with the following information appearing on the display:

- MENU 1 (3): TOT - Odometer;
- MENU 2 (4): engine coolant temperature indicator
- SET UP - Set "Riding Mode" indicator (5);
- Engine RPM indicator(RPM) (7);
- Vehicle speed indicator (8);
- "SERVICE" indicator (if active, only).

Press button (2) to scroll MENU 1 and shift to the following functions:

- TRIP 1 - Trip meter 1;
- TRIP 2 - Trip meter 2;
- TRIP FUEL - Fuel reserve trip meter (if active, only);
- CONS. AVG - Average Consumption;
- CONS. - Instantaneous Consumption;
- SPEED AVG - Average Speed;
- TRIP TIME - Trip Time.

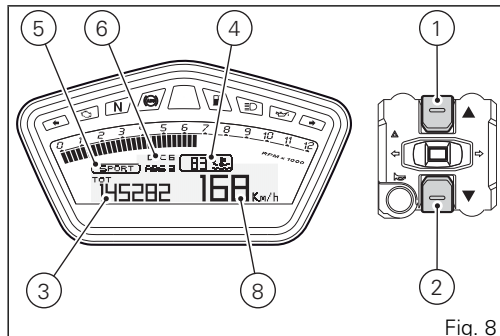

Fig. 8

Press button (1) to scroll MENU 2 and shift to the following Functions:

- AIR - Air Temperature;
- Clock.

Vehicle speed indicator

This function shows vehicle speed (Km/h or mph, based on the selected unit of measurement).

The instrument panel receives information about the actual speed (calculated in km/h) and displays the number increased by 5%.

Maximum speed displayed is 299 km/h (186 mph).

Over 299 km/h (186 mph) a series of dashes will be displayed " - - - " (not flashing).



Note

If the instrument panel does not receive any information, a series of dashes will be displayed " - - - " (not flashing).

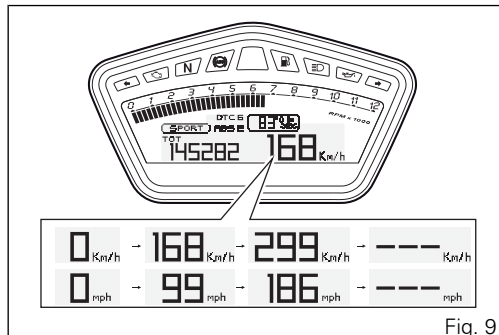

Fig. 9

Engine rpm indicator (RPM)

This function shows engine rpm.

The instrument panel receives the engine rpm information and displays it.

This information is displayed progressively from the left to the right, identifying the rpms.

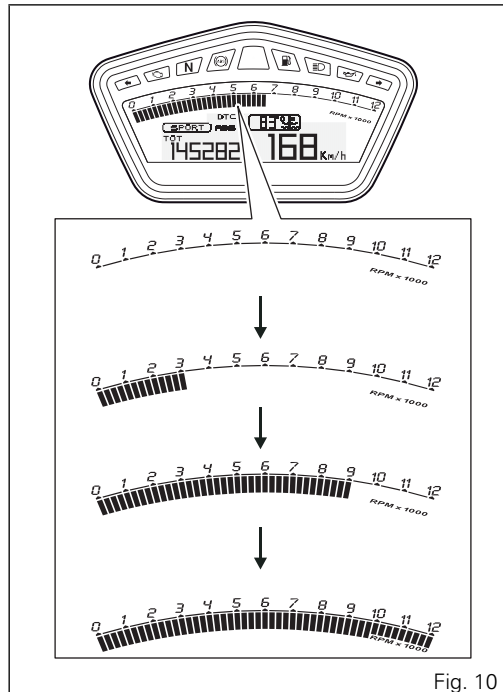

Fig. 10

Menu 1 functions

MENU 1 functions are:

- Odometer (TOT);
- Trip meter 1 (TRIP1);
- Trip meter 2 (TRIP2);
- Fuel reserve trip meter (TRIP FUEL);
- Average Consumption (CONS. AVG);
- Instantaneous Consumption (CONS.);
- Average Speed (SPEED AVG);
- Trip Time (TRIP TIME).

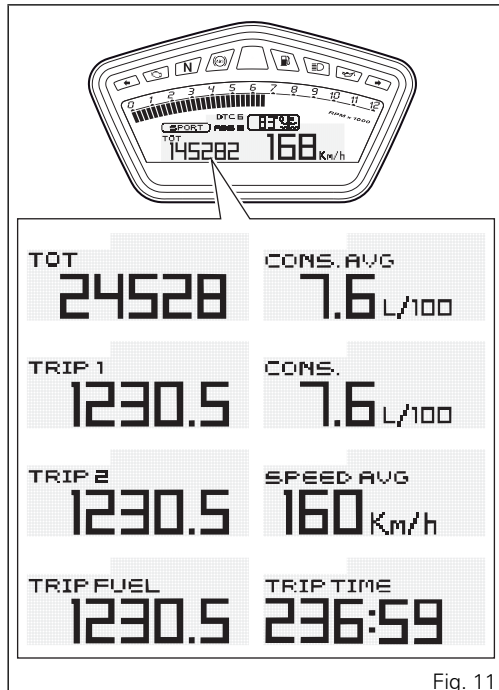

Fig. 11

Menu 1 functions: Odometer (TOT)

This function shows the total distance travelled (km or miles, based on the specific application).

Upon Key-On, the system automatically enters this function.

The odometer reading is stored permanently and cannot be reset.

If the distance travelled exceeds 199999 km (or 199999 miles), the value "199999" will be displayed permanently.



Note

Value will not be lost upon Battery Off.



Note

If a string of flashing dashes " ---- " is displayed within odometer function, please contact a Ducati Dealer or Authorised Service Centre.

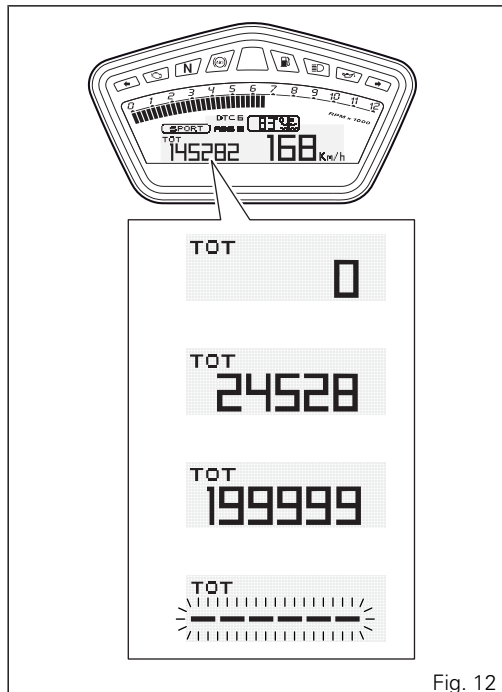

Fig. 12

Menu 1 functions: Trip meter (TRIP 1)

This function shows the partial distance travelled (km or miles, based on the specific application).

Holding button (1) pressed for 3 seconds when this function is displayed resets the trip meter. When the reading exceeds 9999.9, distance travelled is reset and the meter automatically starts counting from 0 again. If the system measurement units are changed at any moment, or if there is an interruption in the power supply (Battery Off), the distance travelled is reset and the count starts from zero (considering the newly set unit of measurement).



Note

When this value is reset, also the "Average fuel consumption", "Average speed" and "Trip time" functions are reset.

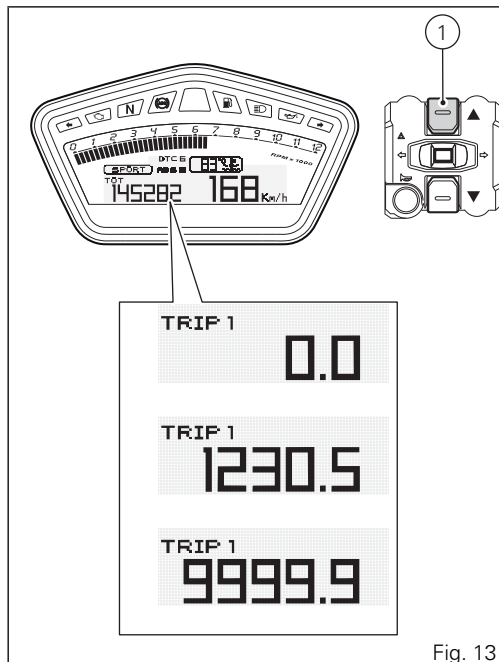

Fig. 13

Menu 1 functions: Trip meter (TRIP 2)

This function shows the partial distance travelled (km or miles, based on the specific application).

Holding button (1) pressed for 3 seconds when this function is displayed resets the trip meter. When the reading exceeds 9999.9, distance travelled is reset and the meter automatically starts counting from 0 again. If the system measurement units are changed at any moment, or if there is an interruption in the power supply (Battery Off), the distance travelled is reset and the count starts from zero (considering the newly set unit of measurement).

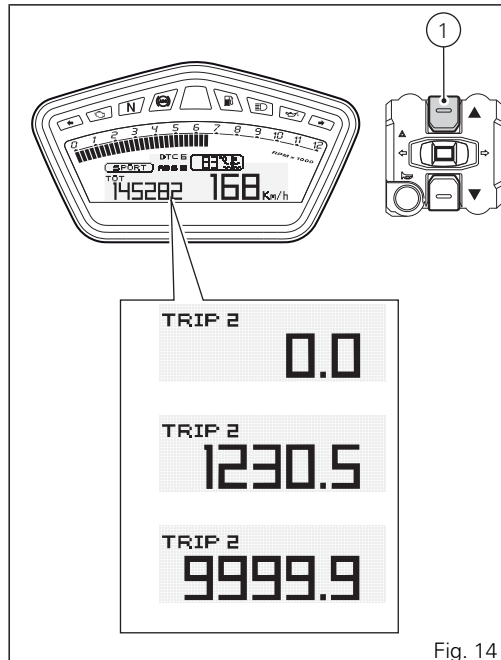

Fig. 14

Menu 1 functions: Partial fuel reserve counter (TRIP FUEL)

This function shows the distance travelled (km or miles, based on the specific application) on fuel reserve. As soon as the fuel reserve warning light comes on, whatever the displayed function, the TRIP FUEL will be automatically enabled; afterwards the other functions of Menu 1 can be scrolled by pressing button (2).

Trip fuel reading remains stored even after Key-Off until the vehicle is refuelled. Count is interrupted automatically as soon as fuel is topped up to above minimum level. When the reading exceeds 9999.9, distance travelled is reset and the meter automatically starts counting from 0 again. When the TRIP FUEL function is disabled, the corresponding page inside Menu 1 will not be available.

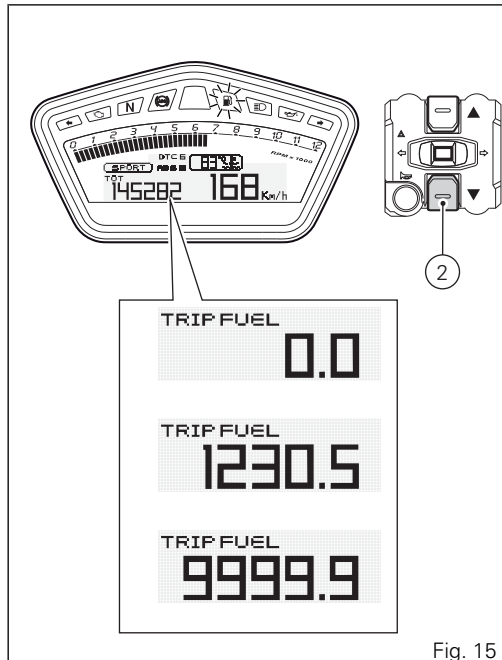

Fig. 15

Menu 1 functions: Average fuel consumption indicator (CONS. AVG)

This function indicates the "average" fuel consumption. The calculation is made considering the quantity of fuel used and the distance travelled since Trip 1 was last reset. When Trip 1 is reset, the value is reset and the first value available is displayed 10 seconds after the reset. Dashes "---" are shown on the display during the first 10 seconds when the value is not yet available. For Europe and Japan versions, the value is expressed in "L / 100" (litres / 100 Km); the "Km / L" (kilometres / litre) unit can nevertheless be set through the "Special Setting" function. For the UK version the reading is in "mpg UK" (miles per UK gallon).

The active calculation phase occurs when the engine is running and the vehicle is stopped (moments when the vehicle is not moving and the engine is off are not considered).

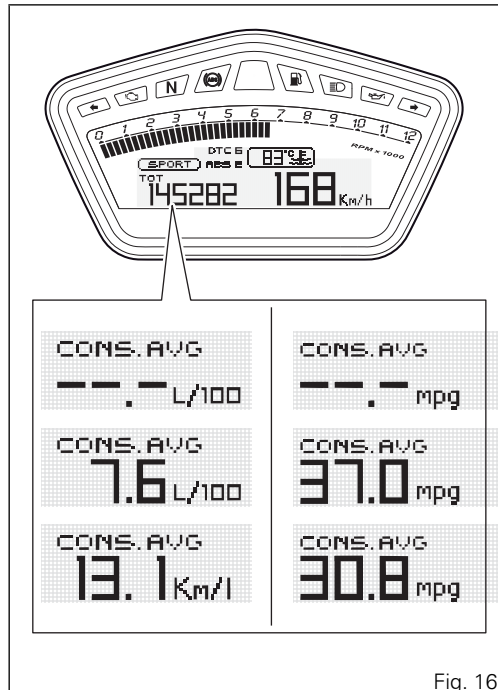

Fig. 16

Menu 1 functions: Instantaneous fuel consumption indicator (CONS.)

This function indicates the "instantaneous" fuel consumption. The calculation is made considering the quantity of fuel used and the distance travelled during the last second. For Europe and Japan versions, the value is expressed in "L / 100" (litres / 100 Km); the "Km / L" (kilometres / litre) unit can nevertheless be set through the "Special Setting" function. For the UK version the reading is in "mpg UK" (miles per UK gallon).

The active calculation phase only occurs when the engine is running and the vehicle is moving (moments when the vehicle is not moving when speed is equal to 0 and/or when the engine is off are not considered). Dashes "--.--" are shown on the display when the calculation is not made.

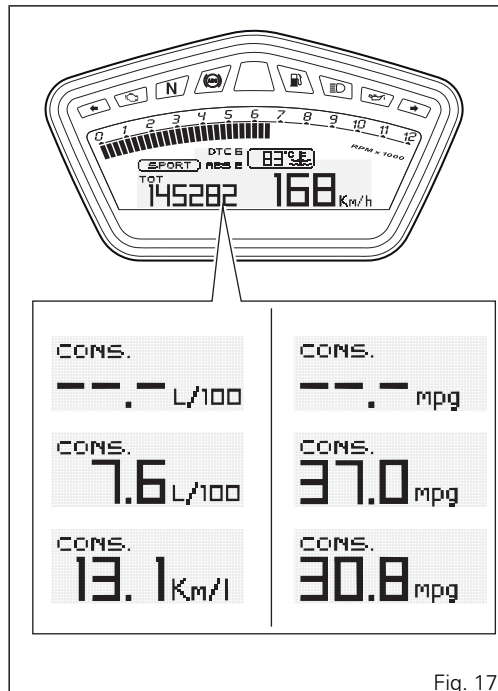

Fig. 17

Menu 1 functions: Average speed indicator (SPEED AVG)

This function shows the average speed of the motorcycle.

The calculation considers the distance and time since Trip 1 was last reset. When Trip 1 is reset, the value is reset and the first value available is displayed 10 seconds after the reset.

Dashes “- - -” are shown on the display during the first 10 seconds when the value is not yet available.

The active calculation phase occurs when the engine is running and the vehicle is stopped (moments when the vehicle is not moving and the engine is off are not considered).

The calculated value is displayed increased by 5% to align it with the vehicle indicated speed.

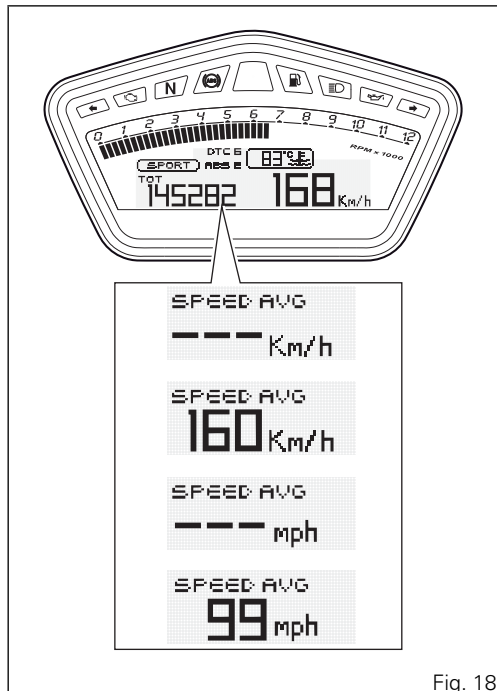

Fig. 18

Menu 1 functions: Trip time indicator (TIME TRIP)

This function shows the vehicle trip time.

The calculation considers the time since Trip 1 was last reset. When Trip 1 is reset, this value is reset as well.

The active phase calculation occurs when the engine is running and the vehicle is stopped (when the vehicle is not moving and the engine is off the time is automatically stopped and restarts when the counting active phase starts again).

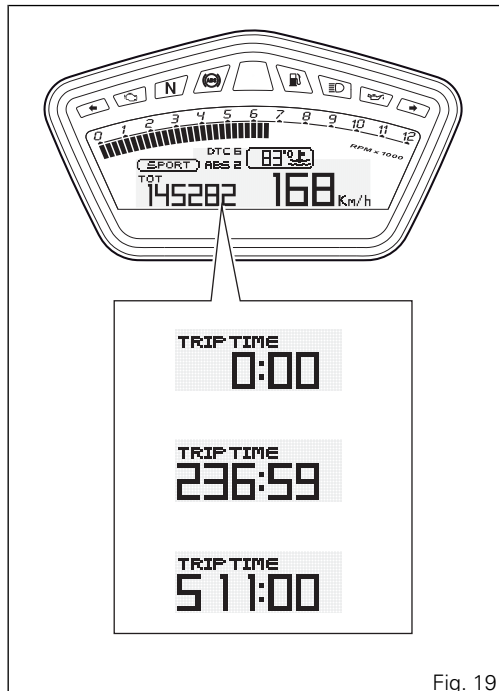

Menu 2 functions

MENU 2 functions are:

- Engine coolant temperature;
- Ambient air temperature(AIR);
- Clock.

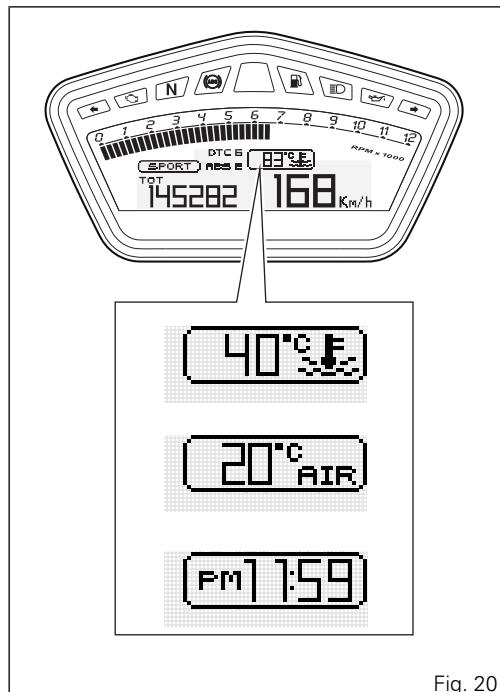

Fig. 20

Menu 2 functions: Coolant temperature

This Function is used to display coolant temperature (°C or °F, based on the specific application).

The instrument panel receives the temperature reading value and displays it.

The reading is indicated as follows:

- if the reading is between -39°C and +39°C "LO" is shown flashing on the instrument panel (steady);
- if the reading is between +40°C and +120°C it appears on the instrument panel (steady);
- if reading is +121 °C or higher, "HI" is shown flashing on the information panel;

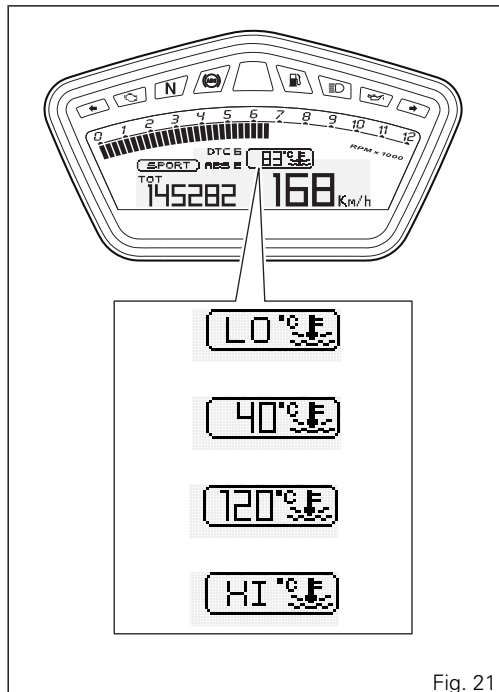

Fig. 21



Note

In the event of a sensor "error", a string of flashing dashes ("—") is shown and the "Engine/vehicle diagnosis - EOBD" light comes on.

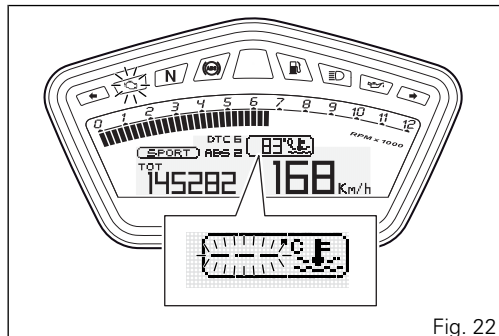

Fig. 22

Menu 2 functions: Air temperature (AIR)

This function indicates ambient temperature. Instrument panel takes temperature value directly from sensor and displays it.



Note

When the vehicle is stopped, the engine heat could influence the displayed temperature.

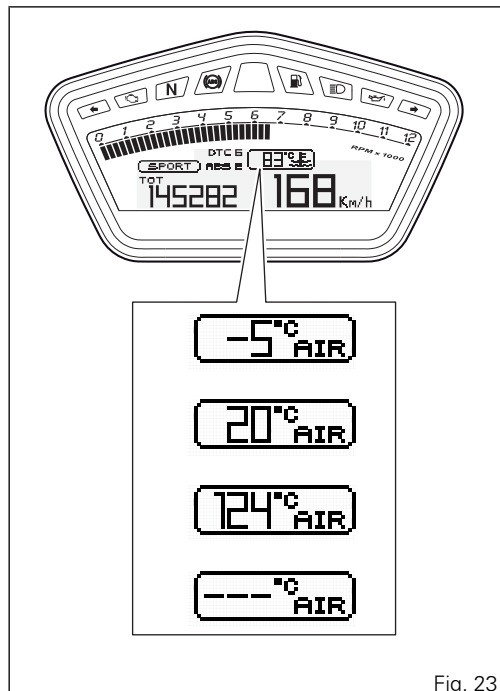

Fig. 23

Menu 2 functions: Clock

This function shows the time.

Time is always displayed as follows:

- AM from 0:00 to 11:59;
- PM from 12:00 to 11:59.

If battery power is suddenly cut off (Batt-OFF), when battery power is restored and upon next Key-On, the clock is reset and restarts operating from "0:00".

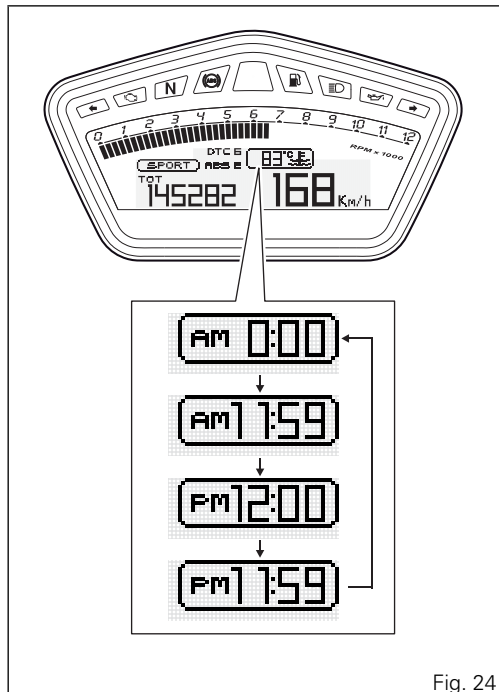

Fig. 24

SET UP - Riding Style set indication

This function indicates the Riding Mode set for the vehicle.

Each riding mode can be changed using the Riding Mode function.

The set riding mode, the Traction Control level (DTC) and corresponding ABS level are indicated.

Three different riding modes can be set: SPORT, TOURING, URBAN.

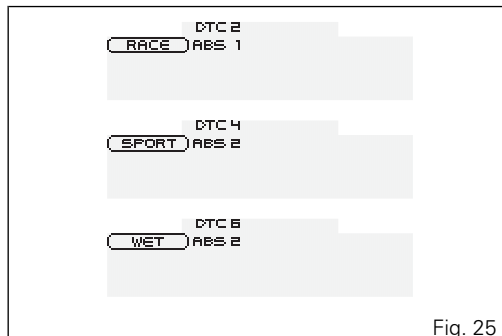

Fig. 25

SERVICE function - Maintenance interventions

This indicator is used to inform the user to contact an authorised Ducati Service Centre to carry out the scheduled maintenance operations (service) on the vehicle.

All maintenance indicators can be "Reset" only by the authorised Ducati Service Centre that will service the vehicle.

First indicator: OIL SERVICE (1000 Km)

The first maintenance indicator is the "OIL SERVICE" signal, coming on when the first 1,000 km (600 miles) are reached on the odometer. The "OIL SERVICE" indicator will come on flashing for 5 seconds upon every Key-ON; while the OIL SERVICE symbol will remain steady on. Both signals will be active until "Reset" by the authorised Ducati Service Centre.

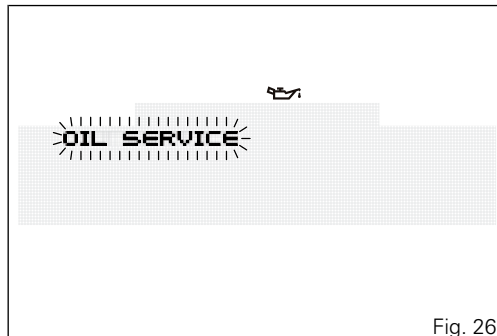

Fig. 26

Mileage countdown indicator - OIL SERVICE or DESMO SERVICE (countdown)

After the "OIL SERVICE" indicator has been "reset" for the first time (after 1,000 km), upon every Key-On the instrument panel will show the following service indicator ("OIL SERVICE" or "DESMO SERVICE") as well as the mileage countdown indicator.

"OIL SERVICE" or "DESMO SERVICE" indicators, as well as the relevant symbols and mileage countdown, will come steady on for 2 seconds upon every Key-On.

When just 1,000 km are left before service threshold is reached, the indicator will be enabled (steady on) upon Key-On for 5 seconds (instead of 2 seconds). Both signals will be active until "Reset" by the authorised Ducati Service Centre.

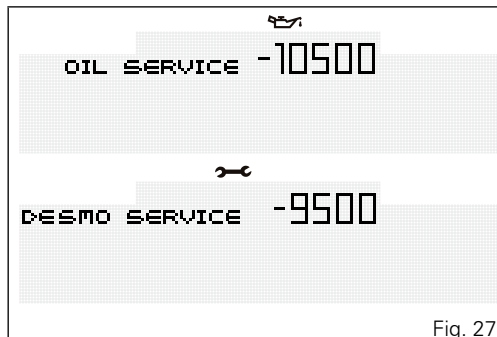

Fig. 27

OIL SERVICE or DESMO SERVICE indicator (mileage reached)

Whenever the threshold required to carry out a maintenance operation is reached, the type of operation to be carried out ("OIL SERVICE" or "DESMO SERVICE") will come on upon each Key-On. The "OIL SERVICE" or "DESMO SERVICE" indicators will come on (flashing) upon each Key-On for 5 seconds; while the OIL SERVICE or DESMO SERVICE symbols will be displayed steady on. Both signals will be active until "Reset" by the authorised Ducati Service Centre.

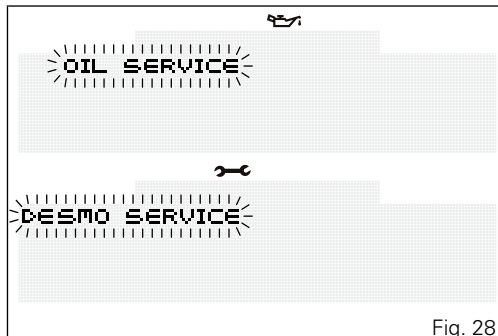
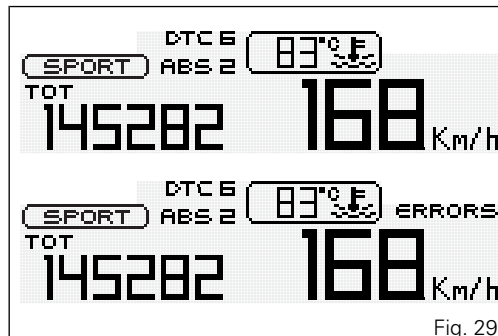

Fig. 28

Active / not active ERRORS indication

This function indicates that one or more errors are present.

The type and number of errors can be displayed using the Setting Menu through the ERRORS function; when "ERRORS" is off, no errors are present.



Indication if the "LAP" function is active/
not active

This function indicates if the LAP function (Lap time)
is active.

When "LAP" is off, function is disabled.

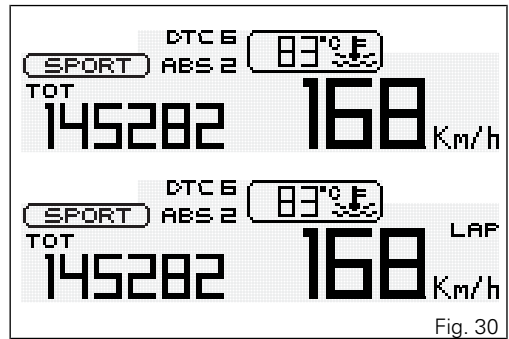

Riding Mode SET UP function (riding style change)

This function allows changing vehicle riding mode. Each riding mode is associated to a different intervention level of the traction control system (DTC - Ducati Traction Control), a different braking control (ABS - Anti-lock Braking System) and a different engine output and power (Engine). To change bike riding mode, simply press button (4) once, and the corresponding menu will be displayed. Whenever vehicle riding mode is changed, the following features will also be changed:

- traction control system "DTC" intervention level (1, 2, 3, 4, 5, 6, 7, 8 and OFF);
- "Engine" power that will consequently change also throttle behaviour (HIGH, MEDIUM and LOW);
- "ABS" system calibration (1, 2 and 3 OFF).

Whenever button (4) is pressed, instrument panel will display all riding modes one after the other in a scroll up-and-down view.

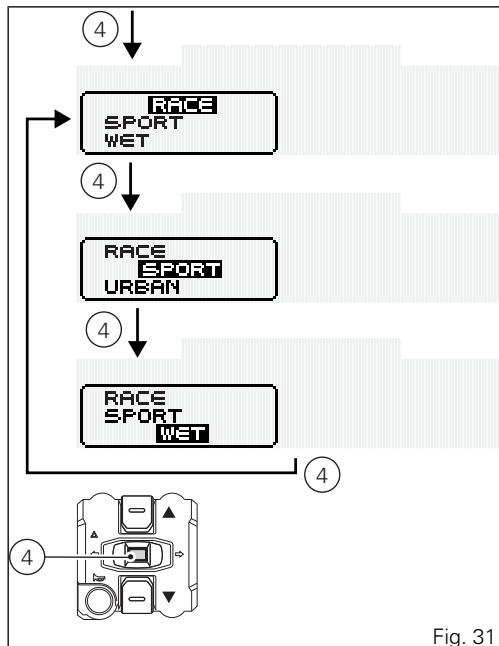

Fig. 31

Once the desired riding mode is highlighted, keep button (4) pressed for 3 seconds and instrument panel will check throttle control position and front and rear brake pressure:

- if throttle control is "closed" and brakes are released or vehicle is stopped, the instrument panel will confirm the selected riding mode (*) and go back to the standard screen view ;
- if throttle control is "open" or brakes are pressed and vehicle is moving, instrument panel will enable the "CLOSE THROTTLE AND RELEASE BRAKES" indicator on the display and, only when all the required conditions are fulfilled (closed throttle and released brakes or vehicle stopped) the instrument panel will confirm the selected riding mode (*) and go back to the standard screen view.



Note

(*) If the change of Riding mode involves a change in the ABS status (on-off or off-on), as soon as the selected riding mode is confirmed, the instrument panel also starts the "procedure for enabling/disabling the ABS".

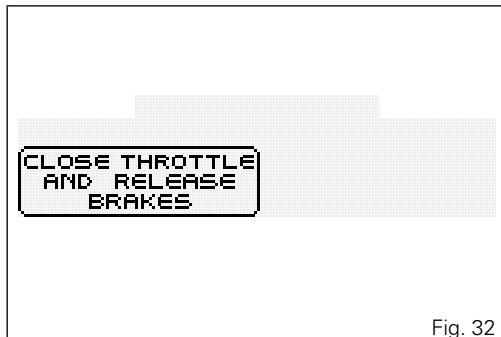

Fig. 32

If throttle control is not closed and brakes are not released or vehicle is not stopped within 5 seconds after the "CLOSE THROTTLE AND RELEASE BRAKES" warning is displayed, the Riding Mode change selection procedure will not be executed and the instrument panel will go back to the standard screen view without any setup change.

If the "SET UP" menu is enabled and button (4) is not pressed for 10 consecutive seconds, the instrument panel will automatically quit the displayed page without any setup change.

Warning

Ducati recommends changing the riding style when the vehicle is stopped. If the riding style is changed while riding, be very careful (it is recommended to change the riding style at a low speed).

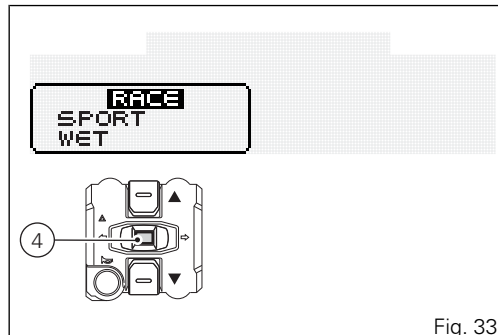

Fig. 33

Error display function (ERRORS)

This function identifies any abnormal vehicle behaviours.

The instrument panel activates any abnormal vehicle behaviours in real time (ERRORS).

If one or more "errors" occur during bike operation, the "ERROR" indicator will appear on display RH side. Under these circumstances (one ore more errors present) the "EOBD" warning light will always come on.

To display error list, access the Setting Menu and select the "ERRORS" page; this page will be active only if at least one error is present.

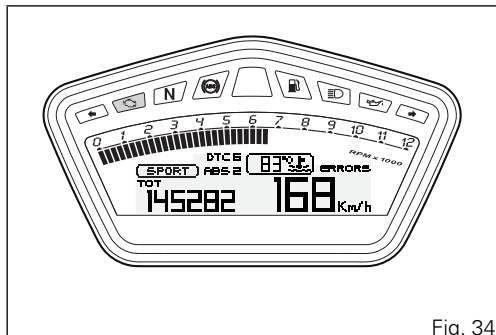

Fig. 34

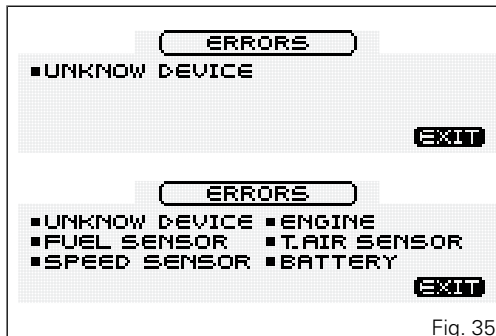

Fig. 35

If one or more errors are present, also "NEXT" and "PREVIEW" will be automatically activated in order to go from one page to another.

To go from one page to another, select "NEXT" and "PREVIEW" with buttons (1) and (2), then press button (4).

The Setting Menu can be quit and accessed at any time by simply pressing button (4), with the highlighted "EXIT" indicator.



Warning

When one or more errors are displayed, always contact a Ducati Dealer or Authorised Service Centre.

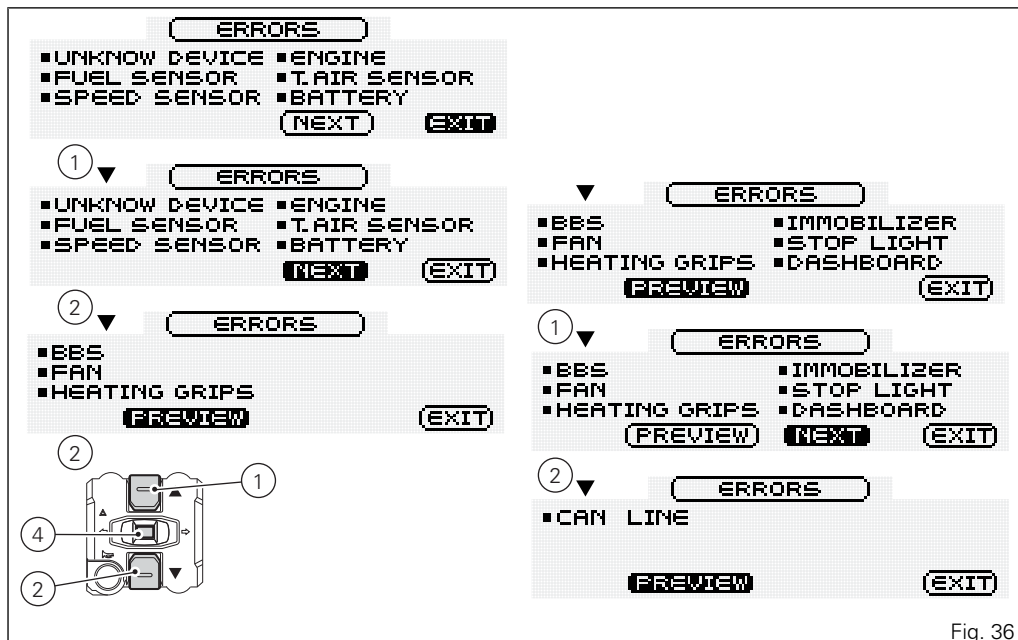

Fig. 36

Hereinafter is a table listing the possible errors:

Displayed error	Description
CAN LINE	CAN line "BUS Off" (communication line of the several control units)
UNKNOWN DEVICE	Control unit not acknowledged by the system - wrong SW
ABS (Antilock Braking System)	ABS control unit faulty communication / operation
BBS (Black Box System)	BBS control unit faulty communication / operation
	BBS control unit general malfunction
	Exhaust valve motor malfunction EXVL
DASHBOARD	DSB control unit faulty communication / operation
IMMOBILIZER	No key
	Key not acknowledged
	Faulty antenna
ENGINE	ECU control unit faulty communication / operation
	General malfunction of the ECU control unit
	Throttle position sensor malfunction
	Throttle motor and/or relay malfunction
	Pressure sensor malfunction
	Engine coolant temperature sensor malfunction

Displayed error	Description
	Intake duct air temperature sensor malfunction
	Injection relay malfunction
	Ignition coil malfunction
	Injector malfunction
	Engine rpm sensor malfunction
	Lambda sensor or Lambda sensor heater malfunction
	Vehicle starting relay malfunction
	Secondary air sensor malfunction
FUEL SENSOR	Reserve NTC sensor malfunction
SPEED SENSOR	Front and/or rear speed sensor malfunction
BATTERY	Battery voltage too high or too low
STOP LIGHT	Stop light not working
FAN	Electric cooling fan malfunction
T_AIR SENSOR	Ambient air temperature sensor malfunction
H.GRIPS	Malfunction of one or both heated grips

SETTING MENU

This menu is used to set/enable some motorcycle functions.

To access the Setting Menu, keep button (2) pressed for two seconds; once this menu is accessed it will no longer be possible to scroll functions on the Display.



Important

For safety reasons, the setting menu can only be accessed when motorcycle speed is lower than or equal to 20 km/h. If this menu is open and the speed of the motorcycle exceeds 20 km/h, the instrument panel automatically exits the menu and returns to the "main" display.

Setting menu includes:

- riding mode customisation (R.MODE);
- backlighting adjustment (B.LIGHT);
- lap time activation and displaying (LAP);
- PIN CODE activation and editing (PIN);
- clock setup (CLOCK);
- measurement unit setup (UNITS);
- battery voltage indicator (BATT.);
- Engine RPM indicator (RPM);
- error indicator, only if one or more errors are present (ERRORS);
- EXIT.

To quit the setting menu, use buttons (1) and (2) to highlight the "EXIT" wording, then press button (4).

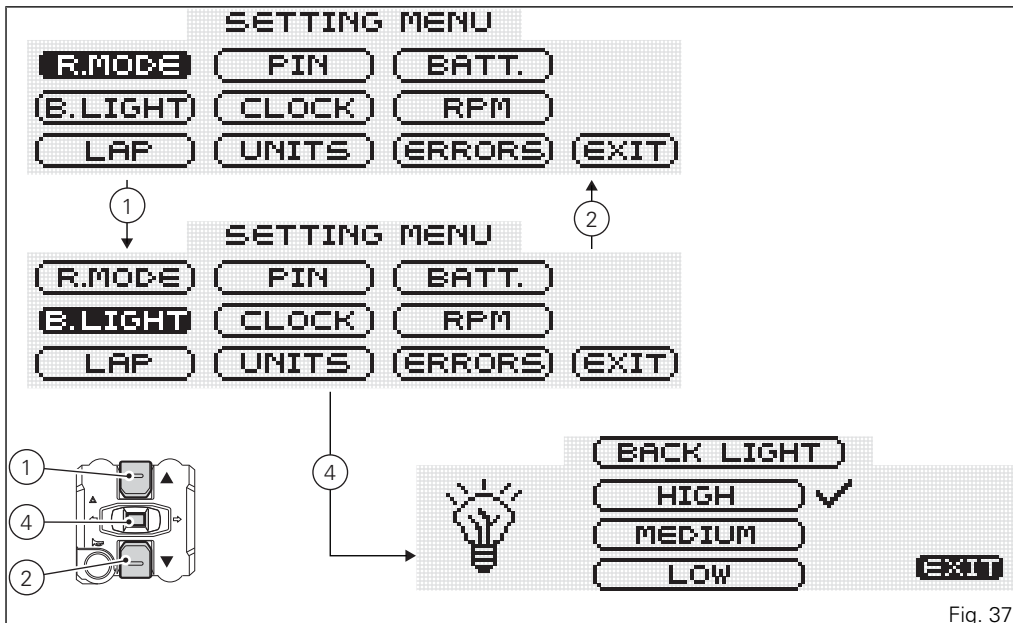

Fig. 37

Customising Riding Modes (R.MODE)

This function customises each riding style.

To display this function, access the Setting Menu and select the R.MODE page.

After entering this function the display will show the three riding modes: RACE, SPORT and WET.

The ALL DEFAULT function will also be displayed; this function is used to reset Ducati default setup parameters for all riding modes.

Buttons (1) and (2) can also be used to select the riding mode you wish to edit or the ALL DEFAULT function.



Note

If on ALL DEFAULT lettering right side a symbol is displayed, this means that the default setup is active, namely that the parameters shown are those set up by Ducati.

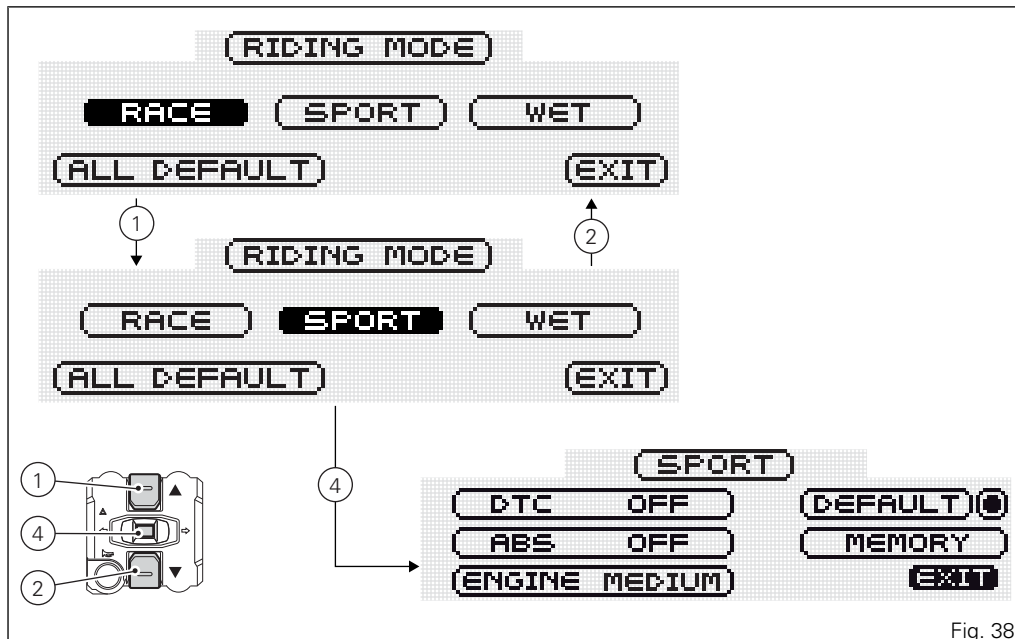

Fig. 38

To customise parameters, select the riding mode you wish to edit and press button (4).

Customisable parameters are DTC (Ducati Traction Control), ABS (Antilock Braking System) and ENGINE (engine power).

Use buttons (1) and (2) to select the parameter you wish to customise.

All edited (customised) parameters are stored inside memory even after a Battery-Off.

The parameters of a single riding mode can also be reset through the DEFAULT function.



Note

If on DEFAULT lettering right side a symbol is displayed, this means that the default setup is active, namely that the parameters shown are those set up by Ducati.



Warning

Changes should only be made to the parameters by people who are experts in motorcycle setup. If the parameters are changed accidentally, use the "DEFAULT" function to reset them.

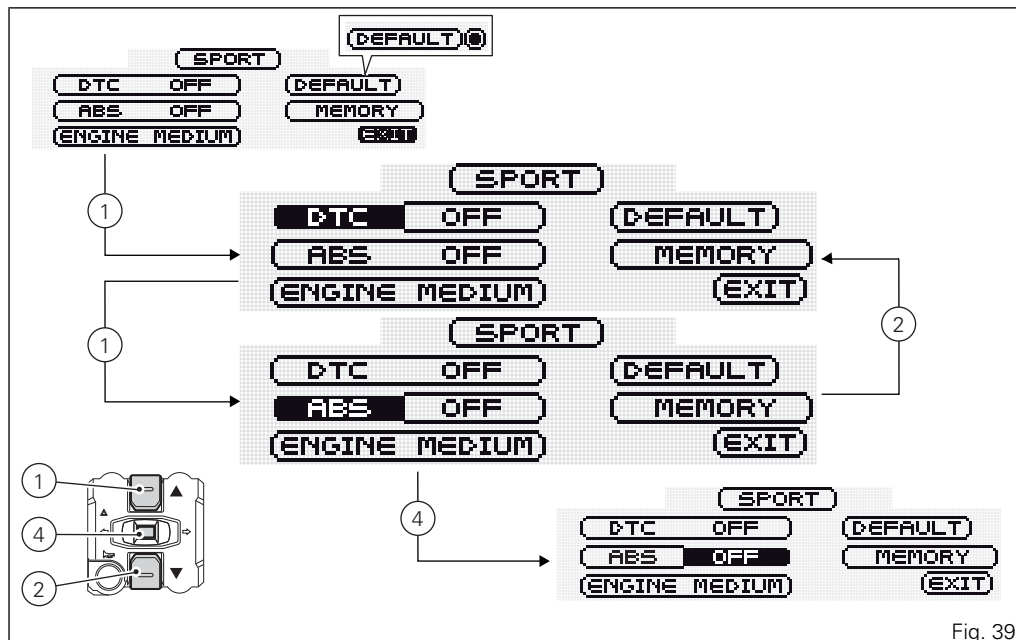

Fig. 39

DTC set up

This function allows customising DTC (Ducati Traction Control) intervention level and, if necessary, disabling it.

To display this function, access the Setting Menu and select the R.MODE page.

Use buttons (1) and (2) to select the riding mode you wish to edit, then press button (4).

Use keys (1) and (2) to select the DTC indicator, then press button (4) to access the setup page.

Now, always using buttons (1) and (2), you can increase or decrease DTC level; press button (4) to confirm the new level.

The different settings are 01, 08 and OFF.



Note

If OFF is set, the DTC will be disabled.

Once the new setup is selected, press button (4). The instrument panel will automatically highlight the "MEMORY" indicator; to store the new setup, keep button (4) pressed for 3 seconds. After this time, the instrument panel will display the "MEMORIZED" indicator for 2 seconds as a confirmation of the change made.

The "EXIT" indicator will be automatically highlighted; press button (4) to quit this page and go back to the setting menu.



Note

If on DEFAULT lettering right side a symbol is displayed, this means that the default setup is active, namely that the parameters shown are those set up by Ducati.

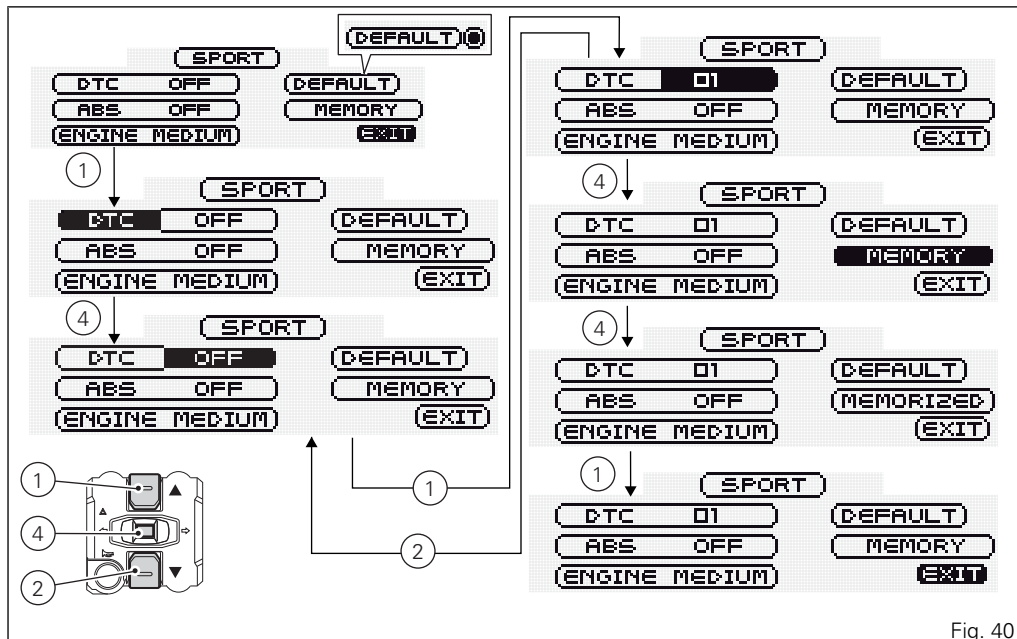

Fig. 40

The following table indicates the most suitable level of DTC intervention for the various riding types as well as the default settings in the "Riding Mode" that can be selected by the rider:

DTC LEVEL	RIDING MODE	USE	DEFAULT?
1	TRACK Professional	Track use for very experienced riders. System permits sliding sideways.	NO
2	TRACK	Track use (and road use for expert riders).	It is the default level for the "RACE" Riding Mode
3	SPORT	Sports use both on the road and on the track.	It is the default level for the "SPORT" Riding Mode
4	TOURING	Touring extra-urban use.	NO
5	CRUISE	Cruise touring use.	NO
6	URBAN	Urban use.	NO
7	RAIN	Wet or moist road.	It is the default level for the "WET" Riding Mode
8	HEAVY RAIN	Wet road with heavy rain or very slippery asphalt.	NO

Tips on how to select the sensitivity level



Warning

The 8 DTC level settings have been calibrated using the same tyres as those originally supplied with your motorcycle (same make, model and size). The use of tyres of different size to the original tyres may alter the operating characteristics of the system.

Motorbike original equipment: (front 120/70ZR17 - rear 180/55ZR17).

- Pirelli Diablo Supercorsa SP;
- Pirelli Diablo Rosso II;
- Pirelli Scorpion Trail.

In the case of minor differences, such as for example, tyres of a different make and/or model than the OE ones, but with the same size (rear = 180/55-17; front = 120/70-17), it may be sufficient to simply select the most suitable level setting from those available to restore optimal system operation. If tyres of a different size class are used or if the tyre size differs significantly from the original tyres, it may be that the system operation is affected so much that none of the 8 available level settings will give satisfactory

results. In this case it is advisable to deactivate the traction control system. If level 8 is selected, the DTC control unit will kick in at the slightest hint that the rear wheel is starting to spin. Between level 8 and level 1 there are a further 8 intermediate levels. The level of DTC intervention decreases in equal steps from level 8 to 1. When level 1 or 2 is selected, the DTC control unit will allow the rear wheel to spin and also slide sideways on exiting a corner; we recommend that this setting is only used on the track and by very experienced riders.

The choice of the correct level depends on 3 main variables:

- 1) The grip (type of tyre, amount of tyre wear, the road/track surface, weather conditions, etc.);
- 2) The characteristics of the path/circuit (bends all taken at similar speeds or at very different speeds);
- 3) The riding mode (whether the rider has a “smooth” or a “rough” style).

Relation of the DTC intervention level to grip conditions

The choice of level setting depends greatly on the grip conditions of the track/circuit (see below, tips for use on the track and on the road).

Relation of the DTC intervention level to the path characteristics

If all the corners on the track/circuit can be taken at a similar speed, it will be easier to find an intervention level that is satisfactory for every bend; on the other hand, if the track has, for example, one corner that is much slower than all the others, it will be necessary to find a compromise level (on the slow corner the DTC will tend to kick in more than on the faster corners).

Relation of the DTC intervention level to the riding mode

The DTC will tend to kick in more with a "smooth" riding style, where the bike is leaned over further, rather than with a "rough" style, where the bike is straightened up as quickly as possible when exiting a turn.

Tips for use on the track

We recommend that level 6 is used for a couple of full laps (to allow the tyres to warm up) in order to get used to the system. Then try levels 5, 4, etc., in

succession until you identify the DTC sensitivity level that suits you best (always try each level for at least two laps to allow the tyres to warm up).

Once you have found a satisfactory setting for all the corners except one or two slow ones, where the system tends to kick in and control too much, you can try to modify your riding mode slightly to a more "rough" approach to cornering i.e. straighten up more rapidly on exiting the corner, instead of immediately trying a different level setting.

Tips for use on the road

Activate the DTC, select DTC 6 and ride the motorcycle in your usual style; if the DTC intervention level seems excessive, try DTC 5; if also this RM is too strong, try DTC 4. If none of the available level settings meets your riding style, you can select the level by following the indications given in the table above until you find the level that suits you best. If changes occur in the grip conditions and/or circuit characteristics and/or your riding style, and the level setting is no longer suitable, switch to the next level up or down and proceed to determine the best setting (e.g. if with level 7 the DTC intervention seems excessive, switch to level 6; alternatively, if on

level 7 you cannot perceive any DTC intervention, switch to level 8).

ABS set up

This function allows customising ABS (Antilock Braking System) intervention level and, if necessary, disabling it. To display this function, access the Setting Menu and select the R.MODE page.

Use buttons (1) and (2) to select the riding mode you wish to edit, then press button (4). Use keys (1) and (2) to select the ABS indicator, then press button (4) to access the setup page. Now, always using buttons (1) and (2), you can increase or decrease ABS level; press button (4) to confirm the new level.

The different settings are 01, 02, 03 and OFF.



Note

If OFF is set, the ABS will be disabled and the corresponding ABS warning light will start flashing.

Once the new setup is selected, press button (4). The instrument panel will automatically highlight the "MEMORY" indicator; to store the new setup, keep button (4) pressed for 3 seconds;

After this time, the instrument panel will display the "MEMORIZED" indicator for 2 seconds as a confirmation of the change made. The "EXIT" indicator

will be automatically highlighted; press button (4) to quit this page and go back to the setting menu.



Note

If ABS OFF is selected and stored, Ducati recommends paying the utmost attention while riding and braking your bike.



Note

If on DEFAULT lettering right side a symbol is displayed, this means that the default setup is active, namely that the parameters shown are those set up by Ducati.

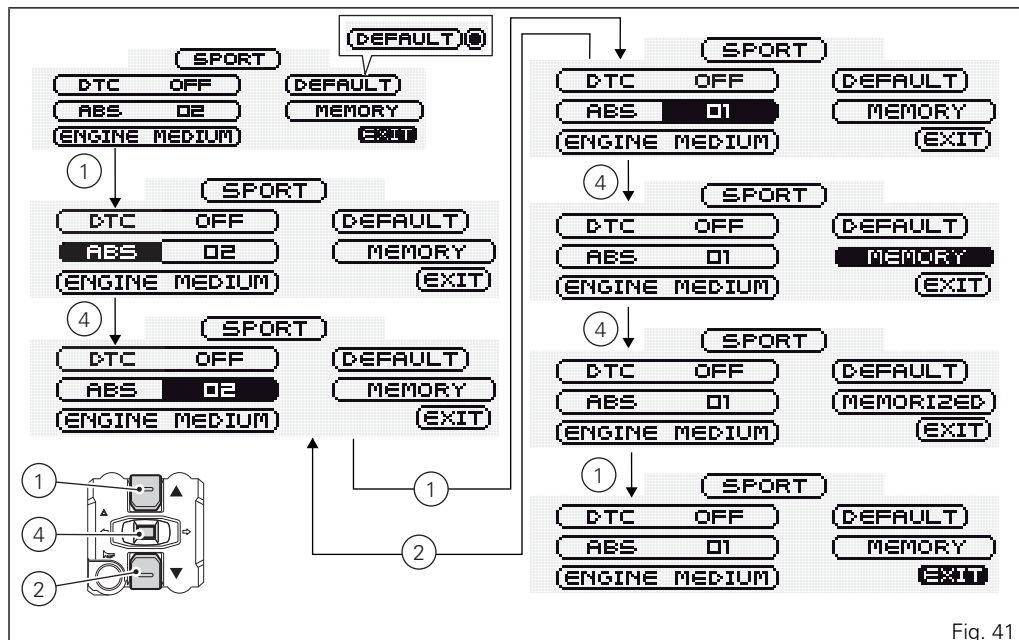

Fig. 41

The following table indicates the most suitable level of ABS intervention for the various riding types as well as the default settings in the "Riding Mode" that can be selected by the rider:

LEVEL	MODE	USE	DEFAULT?
OFF		The ABS is disabled.	NO
1	RACE	Exclusively for track use, for expert riders (not recommended for road use). In this mode the ABS works only on the front wheel preventing it from locking and ensuring the best possible performance, whereas there is no control on the rear wheel. The lift up* control is NOT active.	It is the default level for the "RACE" Riding Mode.
2	SPORT	For road use in good grip conditions. Under this mode, ABS is active on both wheels. Lift-up* prevention controls are active; this calibration favours braking power and ensures, at the same time, good stability levels during braking and lift-up control*.	It is the default level for the "SPORT" riding mode.
3	WET	For use under any riding condition. Under this mode, ABS is active on both wheels. This calibration favours vehicle max. stability and lift-up prevention and ensures, at the same time, a top level max. deceleration performance.	It is the default level for the "WET" Riding Mode.

* Rear wheel lift-up upon maximum deceleration.

Tips on how to select the sensitivity level



Warning

The ABS system levels of your vehicle were calibrated using the same tyres as those originally supplied with your motorcycle .

If tyres of a different size class are used or if the tyre characteristics differ significantly from the original ones, system operation could be affected so much and no longer be safe. We do not recommend using tyres having a different size class from those approved for your vehicle.

Motorbike original equipment: (front 120/70ZR17 - rear 180/55ZR17).

- Pirelli Diablo Supercorsa SP;
- Pirelli Diablo Rosso II;
- Pirelli Scorpion Trail.

If level 3 is selected, the ABS system will be activated to ensure a very stable braking and a good bike control as well as to prevent any lift-up, thus allowing a good vehicle alignment during the whole braking

action. When shifting from level 3 to level 2, braking power will be favoured compared to max. stability control and lift-up prevention, which is nevertheless still active. Level 1 has been specifically designed for use on the track: no lift-up prevention control is active and the ABS does not work on the rear wheel.

The choice of the correct level mainly depends on the following parameters:

- 1) Tyre/road grip conditions (type of tyre, amount of tyre wear, the road/track surface, weather conditions, etc.).
- 2) Rider experience and skill.

Under poor grip conditions (see point 1) and/or for less experienced riders, we recommend using level 3.

ENGINE set up

This function allows customising ENGINE power and output.

To display this function, access the Setting Menu and select the "R.MODE" page. Use buttons (1) and (2) to select the riding mode you wish to edit, then press button (4).

Use buttons (1) and (2) to select the "ENGINE" indicator, then press button (4) to access the setup page.

Now, always using buttons (1) and (2), you can increase or decrease ENGINE level; press button (4) to confirm the new level.

The different settings are HIGH, MEDIUM and LOW. Once the new setup is selected, press button (4). The instrument panel will automatically highlight the "MEMORY" indicator; to store the new setup, keep button (4) pressed for 3 seconds.

After this time, the instrument panel will display the "MEMORIZED" indicator for 2 seconds as a confirmation of the change made. The "EXIT" indicator will be automatically highlighted; press button (4) to quit this page and go back to the setting menu.



Note

If on DEFAULT lettering right side a symbol is displayed, this means that the default setup is active, namely that the parameters shown are those set up by Ducati.

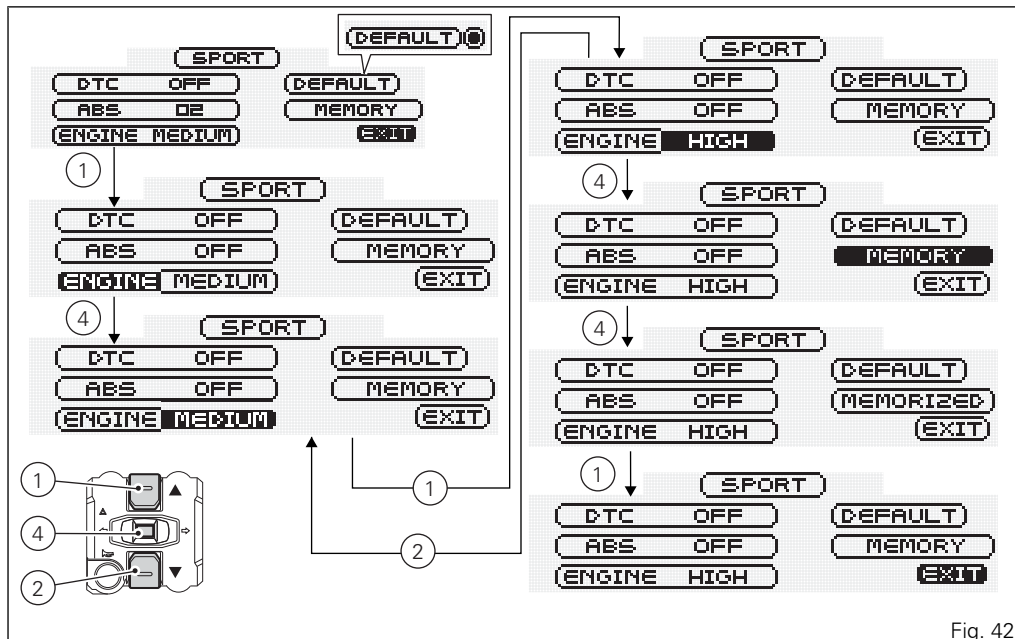

Fig. 42

ALL DEFAULT (Resetting the default parameters of all Riding Modes)

This function allows restoring all Ducati setup parameters for RACE, SPORT, and WET Riding Modes.

To display this function, access the Setting Menu and select the "R.MODE" page.

Use buttons (1) and (2) to select the "ALL DEFAULT" indicator, then keep button (4) pressed for 3 seconds.

Now the "ALL DEFAULT" wording will be replaced by the "PLEASE WAIT..." indicator, which will be displayed for 3 seconds to inform the user that the instrument panel is restoring the default parameters for all Riding Modes.

After this time (3 seconds), the "EXIT" indicator will be automatically highlighted; press button (4) to quit this page and go back to the setting menu.



Note

If on ALL DEFAULT lettering right side a symbol is displayed, this means that the default setup is active, namely that the parameters shown are those set up by Ducati.

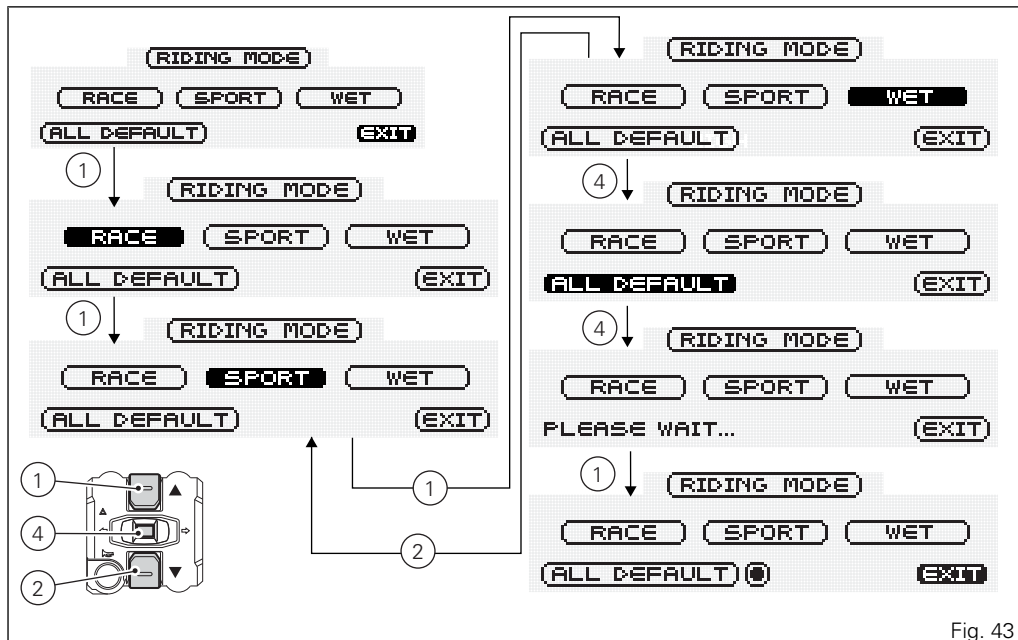

Fig. 43

DEFAULT (Resetting the default parameters of a single Riding Mode)

This function allows restoring all Ducati setup parameters for a single Riding Mode.

To display this function, access the Setting Menu and select the "R.MODE" page.

Use buttons (1) and (2) to select the riding mode for which you wish to restore the default parameters, then press button (4). Use buttons (1) and (2) to select the "DEFAULT" indicator, then keep button (4) pressed for 3 seconds.

Now the "ALL DEFAULT" wording will be replaced by the "PLEASE WAIT..." indicator, which will be displayed for 3 seconds to inform the user that the instrument panel is restoring the default parameters for the selected Riding Mode.

After this time (3 seconds), the "EXIT" indicator will be automatically highlighted; press button (4) to quit this page and go back to the setting menu.



Note

When the default settings are active, a symbol (circle with a dot) is always displayed close to the DEFAULT indicator.

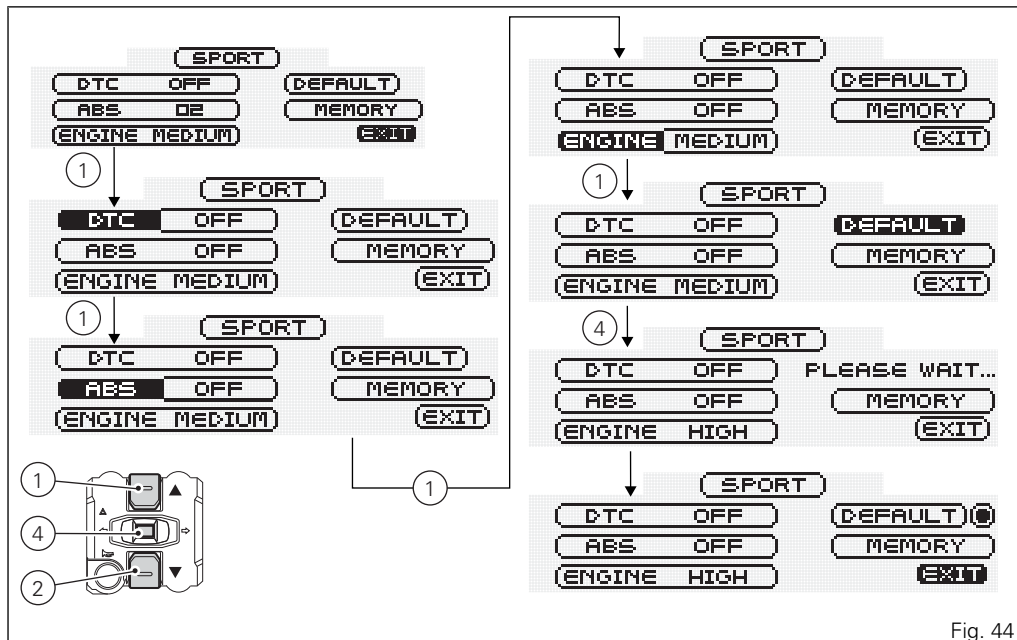

Fig. 44

Dashboard backlighting setting function (B.LIGHT)

This function allows dashboard backlighting setting. To display this function, access the Setting Menu and select the "B.LIGHT" page.

The information will be displayed as follows:

- the tick (V) indicates that the setting is currently enabled;
- use buttons (1) and (2) to highlight the new setting;
- to store the new setting, press button (4); the tick (V) will move on the stored condition.

To quit this page, highlight the "EXIT" wording, and press button (4).

- 1) HIGH setting: when this condition is stored, backlighting is at the max. level.
- 2) MEDIUM setting: when this condition is stored, backlighting is reduced by approx. 30% compared to max. level.
- 3) LOW setting: when this condition is stored, backlighting is reduced by approx. 70% compared to max. level.



Note

In the event of an interruption of the power supply from the battery, when power is restored at the next Key-On, the backlighting will always be set by default to maximum brightness.

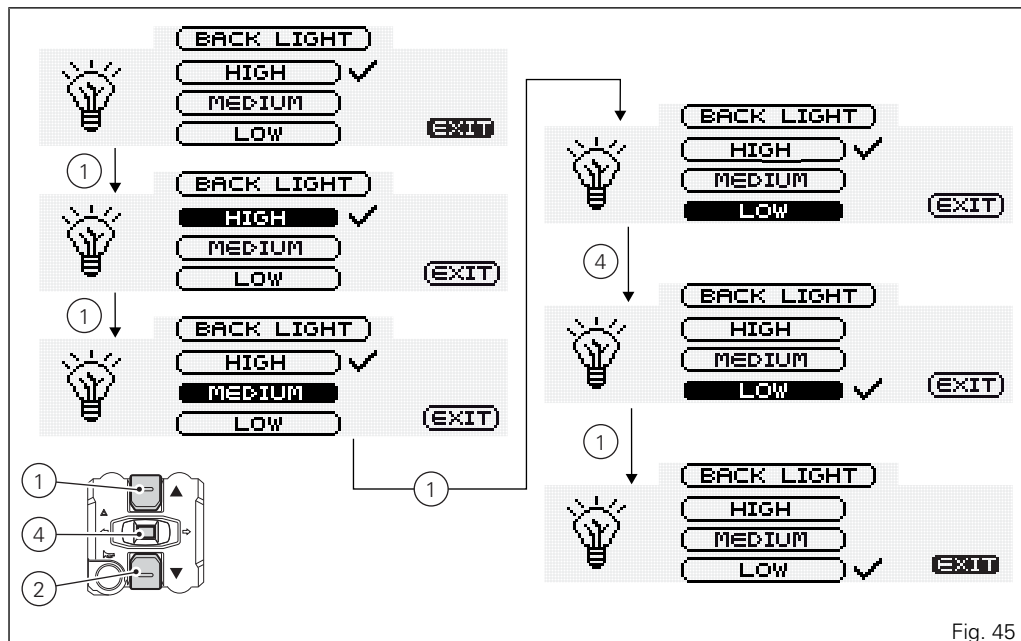

Fig. 45

Lap time function (LAP): LAP activation/ deactivation

This function activates and deactivates the LAP function (lap time).

To display this function, access the Setting Menu and select the "LAP" page.

The information will be displayed as follows:

- the tick (V) indicates that the setting is currently enabled;
- use buttons (1) and (2) to highlight the new setting;
- to store the new setting, press button (4); the tick (V) will move on the stored condition.

To quit this page, select the "EXIT" wording, and press button (4). Storing the "OFF" condition disables the LAP function.

Storing the "ON" condition enables the LAP function.



Note

When the LAP function is enabled, button (3) can be used both as high beam Flash and lap time Start/Stop.

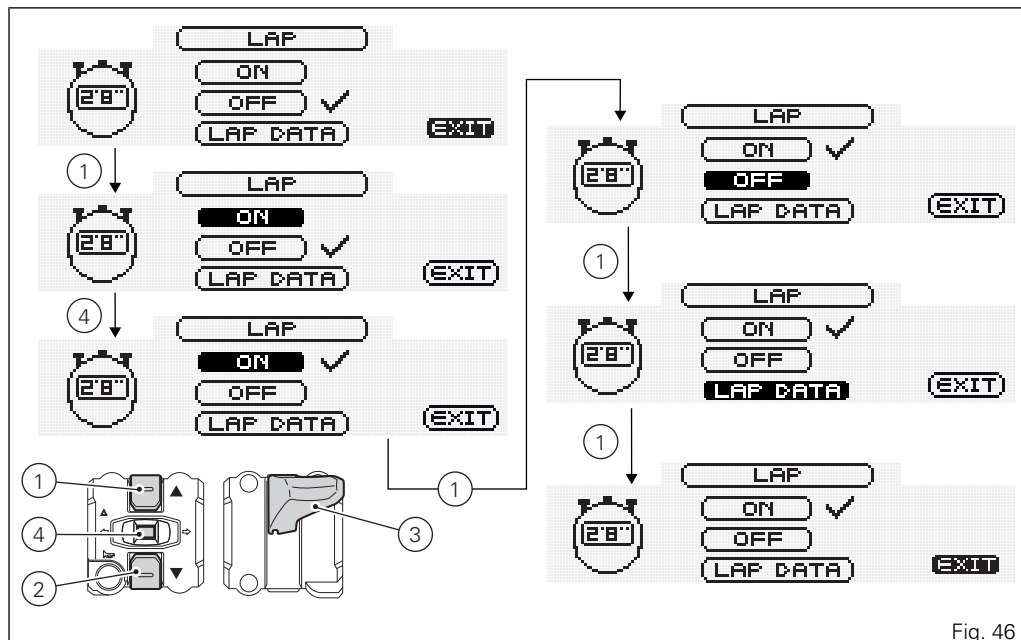

Fig. 46

Lap time function (LAP): LAP registration

This function is used to describe how lap times (LAP) are stored.

If function is enabled, lap time can be stored as follows:

- after the first time you press button (3) the first lap counter is started and the instrument panel displays the "START LAP" indicator (flashing) for 4 seconds, before reverting to previous display;
- from now on, each time you press button (3), the instrument panel will show the lap time for 10 seconds (steady), before reverting to the previous display.

Up to 30 lap times can be stored. If the memory is full, each time you press button (3), the instrument panel will not be able to save any lap time and, for 4 seconds, the display will show the message "LAP MEM. FULL" (flashing) until the memory is reset. When the LAP function is set to Off, the current lap is not stored. If the LAP function is active and the display is suddenly switched off (Key-Off), the LAP function is switched off automatically: even if the timer was ON, the lap in progress will not be saved. If the timer is not stopped, when it reaches 9 minutes, 59 seconds and 99 hundredths, it restarts

from 0 (zero) and continues until the function is switched off.

If the LAP function is enabled without resetting the memory and there are less than 30 laps stored in the memory (for instance: 18 laps), the instrument panel will store any remaining laps until the memory is full (in this case, it will store an additional 12 laps).

This function only displays lap times being stored; however, other data (MAX Speed, RPM MAX, rev limiter - if tripped) are saved for a subsequent complete display in the LAP displaying function.

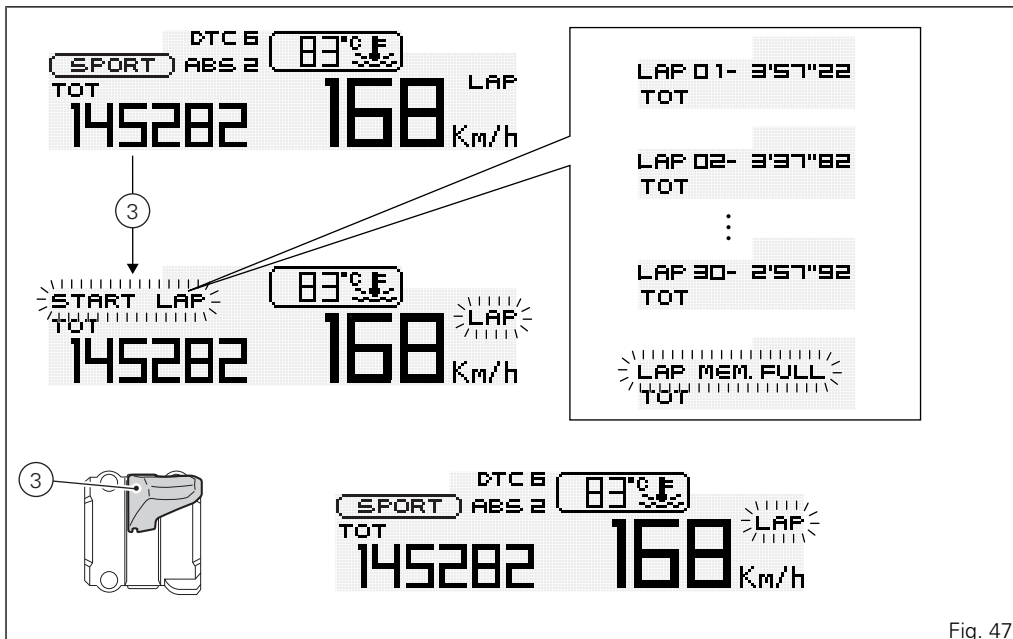

Fig. 47

Lap time function (LAP): stored LAP display

This function displays the stored LAPs. To display this function, access the Setting Menu and select the LAP page. Use buttons (1) and (2) to highlight the "LAP DATA" indicator, then press button (4).

The instrument panel will display the information as follows:

- lap number being displayed (example: No.1);
- NEXT indicator to view next LAP;
- ERASE indicator to delete all stored lap times;
- TIME: and then lap time (example: 1'50''97);
- RPM MAX: max. engine RPM reached during the stored LAP;
- SPEED MAX: max. speed reached during the stored LAP.

To quit this page, select the "EXIT" wording, and press button (4).

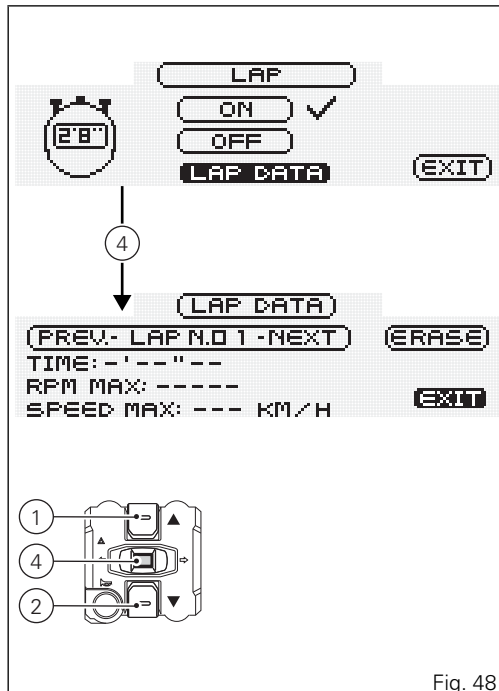





Fig. 48

 **Note**
MAX stored speed is reached during lap
(increased by 5%).

 **Note**
If MAX speed reading exceeds 299 km/h (186
mph) while the information is stored, speed reading
is displayed (example: 316 km/h).

 **Note**
If no lap times are saved in memory, the 30 lap
times will be displayed as 0'00''00, the RPM max.
number equal to 0 (zero) and the MAX speed value
equal to 0 (zero).

 **Note**
If the engine trips the threshold before the rev
limiter kicks in or makes the rev limiter kick in during
lap saving, the corresponding Over Rev light will
come on during the displaying of the stored lap times.

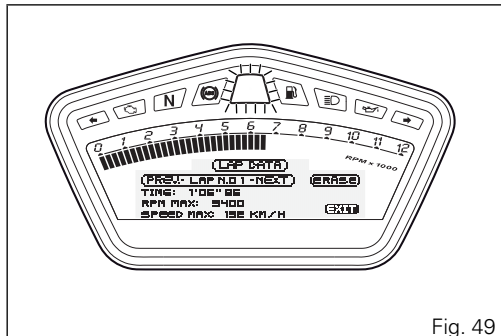

Fig. 49

To display other stored lap times, press buttons (1) and (2) to highlight NEXT (or PREV), then press button (4); each time you press button (4) the next lap will be displayed.

To erase all stored lap times, highlight the ERASE indicator and keep button (4) pressed for 3 seconds.



Note

If the stored times are deleted while the LAP function is active, it will be automatically deactivated.

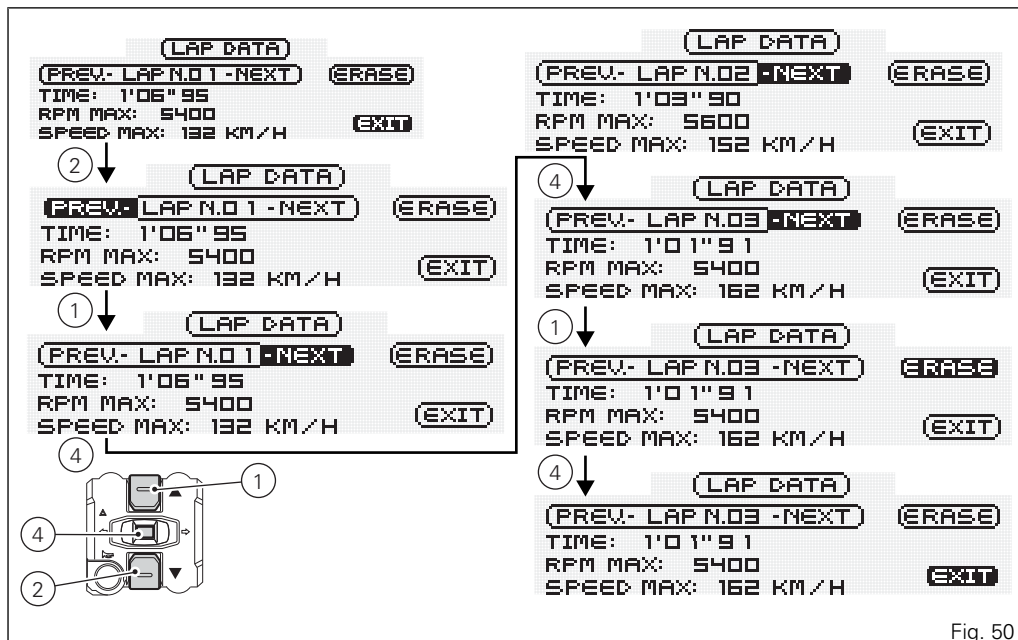

Fig. 50

Clock setting function (CLOCK)

This function allows setting the clock. To display this function, access the Setting Menu and select the "CLOCK" page. To access the setting page, keep button (4) pressed for 3 seconds. After this time, the "SETTING..." indicator will be enabled to confirm that the setting page is active.

On entering this mode, the message "AM" will flash;

- press button (2): PM will start flashing;
- if you press button (2), the mode will go back to previous setting (if it is 00:00, when toggling from AM to PM, 12:00 will be displayed).

Pressing button (4) gives access to the hour setting mode; hours start to flash;

- each time you press button (2), the count will increase cyclically in steps of one hour;
- if button (2) is held pressed, the count will increase cyclically in steps of one hour every second (when the button is held depressed, the hours do not flash).

Pressing button (4) gives access to the minutes setting mode; minutes start to flash;

- each time you press button (2), the count will increase cyclically in steps of one minute;
- if you hold button (2) pressed, the count will increase cyclically in steps of 1 minute every second.
- If button (2) is held depressed for over 5 seconds, minutes will increase by 1 minute every 100 ms (while button (2) is held depressed, seconds will not flash).

To confirm (store) the new time setting, press button (4). The "EXIT" indicator will be automatically highlighted; press button (4) to quit this page and go back to the setting menu.



Note

If a battery is cutoff, when the voltage is restored and at the next Key-On, the clock must be reset (it starts automatically from 00:00).

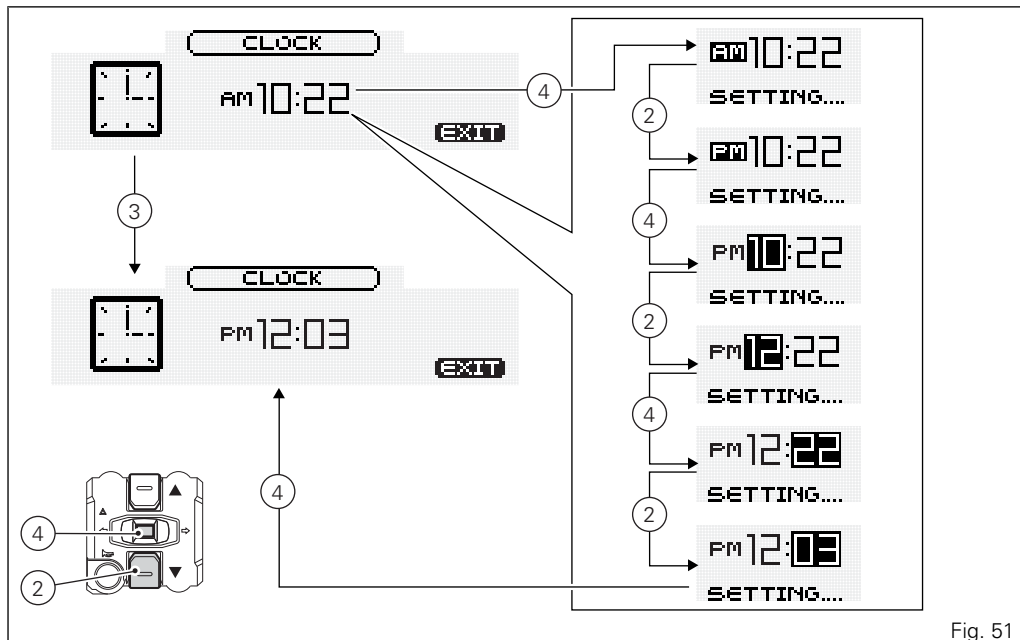

Fig. 51

Battery voltage function (BATTERY)

Thanks to this function it is possible to check vehicle battery condition. To display this function, access the Setting Menu and select the "BATT" page.

The information will be displayed as follows:

- if battery voltage is between 11.8 and 14.9 Volt the reading will be displayed steady;
- if battery voltage is between 11.0 and 11.7 Volt the reading will be displayed flashing;
- if battery voltage is between 15.0 and 16.0 Volt the reading will be displayed flashing;
- if battery voltage is equal to or less than 10.9 Volt, "LOW" is shown flashing;
- if battery voltage is equal to or more than 16.1 Volt, "HIGH" is shown flashing;



Note

Dashes "--" are shown on the display when no value is available.

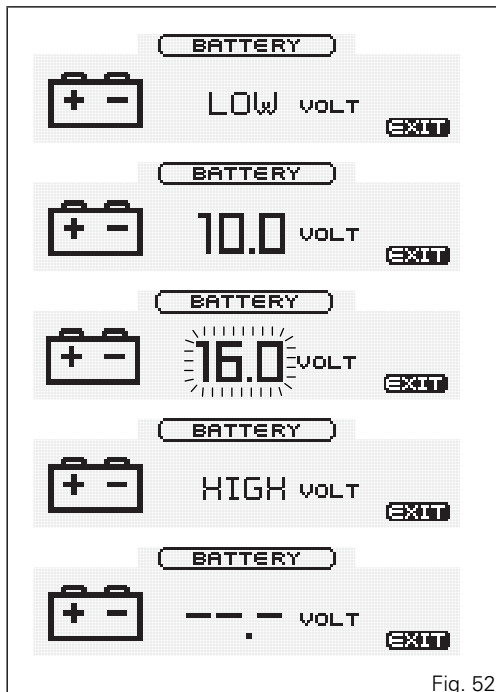

Fig. 52

Engine rpm digital indication (RPM)

This function displays the number of RPMs for improved accuracy when setting idle rpm.

To display this function, access the Setting Menu and select the "RPM" page.

The display shows the numerical value of the RPM with a precision of 50 rpm.

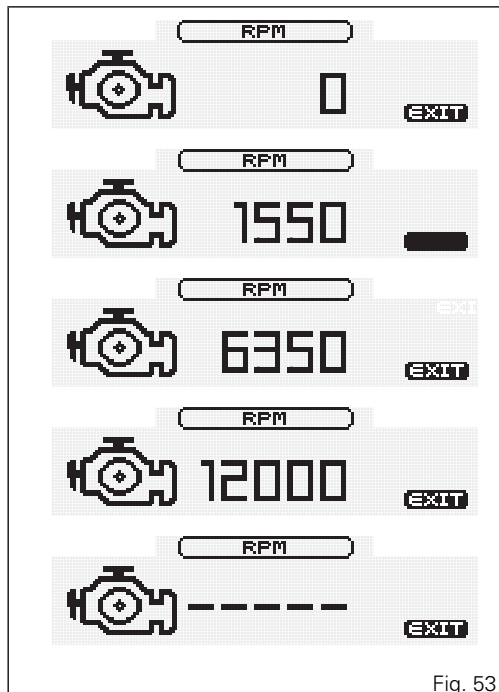

Fig. 53

Immobilizer code (PIN CODE)

This function provides vehicle temporary starting in the event the Immobilizer system is malfunctioning.



Note

The PIN CODE function must be activated by entering your 4 digit PIN in the instrument panel, otherwise the vehicle cannot be turned on temporarily in the case of a malfunction.

To view this function, access the Setting menu, and press button (4) to enter the "PIN" page.

- If the PIN CODE has not been entered yet, the "PIN Activation (INSERT NEW PIN)" function will be displayed.
- If the PIN CODE has already been entered, the "PIN Editing (MODIFY PIN CODE)" function will be displayed.

To temporary start the vehicle in the event the Immobilizer system is malfunctioning, refer to the "Entering the PIN code to unlock the vehiclepage 106".



Warning

The motorcycle owner must activate (store) the PIN code; if there is already a stored PIN, contact an Authorised Ducati Dealer to have the function "reset". To perform this procedure, the Authorised Ducati Dealer may ask you to demonstrate that you are the owner of the motorcycle.

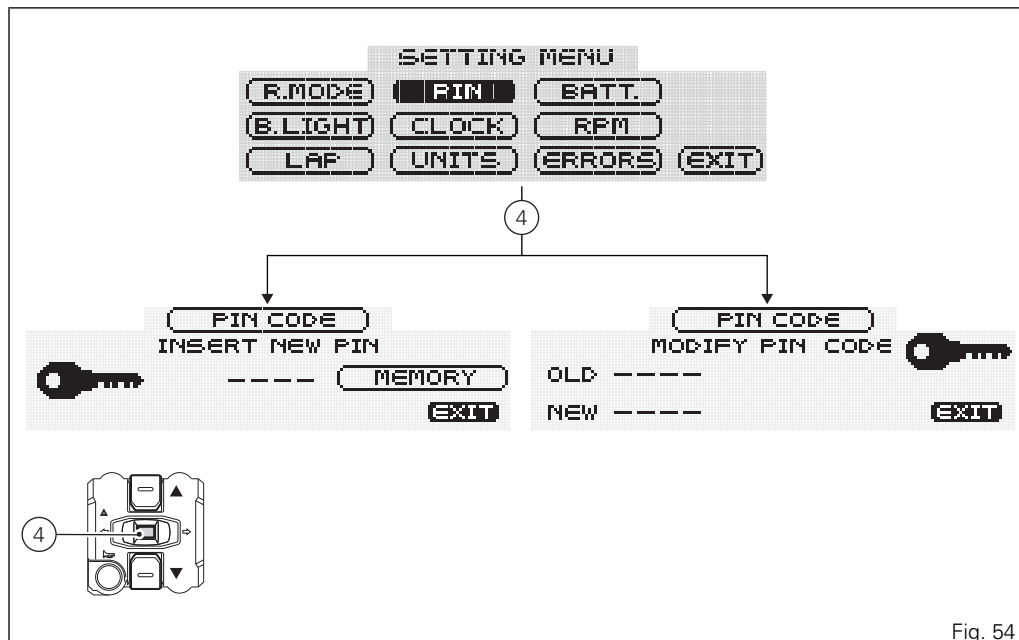

Fig. 54

PIN activation

This function allows activating your own PIN CODE to start the vehicle even if the Immobilizer system is malfunctioning.

To display this function, access the Setting Menu and select the "PIN" page.



Note

If the PIN CODE has already been entered, the "MODIFY PIN CODE" indicator will be displayed.

When accessing this function, the "INSERT NEW PIN" indicator and four dashes "----" will be displayed. Now enter a 4-digit code.

Entering the code:

- each time you press button (2), the highlighted number increases from 0 to 9 and back to 0, press button (4) to confirm;
- repeat this procedure until entering the fourth digit.
- Press button (4) again to confirm.

Once PIN code is entered, the "MEMORY" indicator will be automatically highlighted.

To store the entered PIN code, keep button (4) pressed for 3 seconds.

The "MEMORIZED" indicator will be displayed to confirm that the PIN Code has been stored in the memory.

From now on, each time the "PIN CODE" function is accessed, the display will read "MODIFY PIN CODE", meaning that the PIN CODE can be modified.

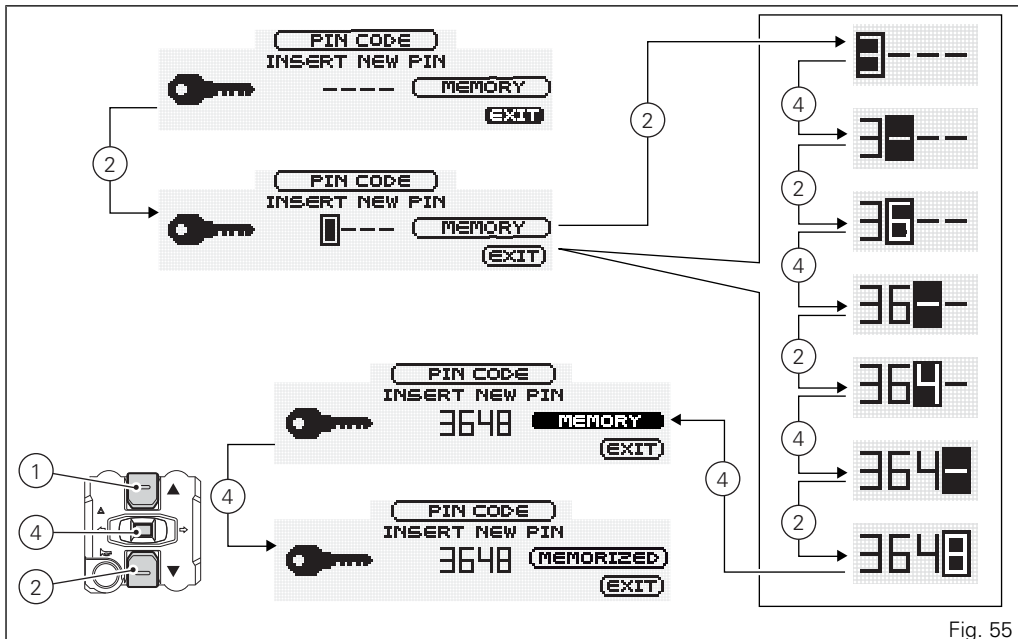

Fig. 55

Changing the PIN CODE

This function changes your four number PIN CODE. To display this function, access the Setting Menu and select the "PIN" page.



Note

If the "INSERT NEW PIN" indicator and dashes "- - - -" are displayed, function is not active as the PIN CODE has never been entered. Enter your PIN Code with the "PIN Activation" function.

Once function is accessed, the "MODIFY PIN CODE" indicator will be displayed; press button (1) or (2) to change the PIN code.



Note

To change the PIN, you must know the currently stored PIN.

The "OLD" indicator and four dashes "- - - -" will be displayed; now enter the old 4-digit PIN number stored before.

Entering the old PIN code (OLD PIN):

- each time you press button (2), the highlighted number increases from 0 to 9 and back to 0, press button (4) to confirm;
- repeat this procedure until entering the fourth digit.
- Press button (4) again to confirm.

If code is wrong, the "ERROR" indicator (wrong old code) will be displayed for 3 seconds, then the instrument panel will display again the "EXIT" indicator.

If code has been correctly entered, the "CORRECT" indicator will be displayed, and the first dash will be highlighted to indicate that it is possible to enter the new 4-digit code.

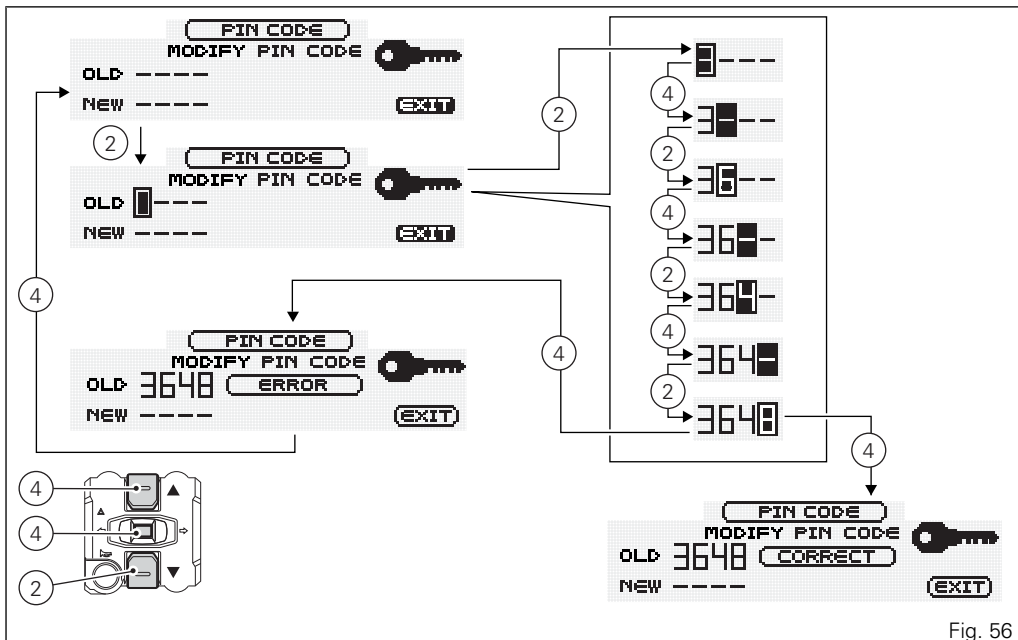

Fig. 56

Entering the new PIN code (NEW PIN):

- each time you press button (2), the highlighted number increases from 0 to 9 and back to 0, press button (4) to confirm;
- repeat this procedure until entering the fourth digit.
- Press button (4) again to confirm.

Once the fourth digit has been entered, the "MEMORY" indicator will be automatically highlighted.

To store the new PIN code, keep button (4) pressed for 3 seconds.

The "MEMORIZED" indicator will be displayed to confirm that the PIN code has been stored, then the "EXIT" indicator will be highlighted.

Press button (4) to go back to the setting menu.

The PIN CODE modification procedure is complete.



Note

There is no limit to the amount of times you can change your PIN CODE.

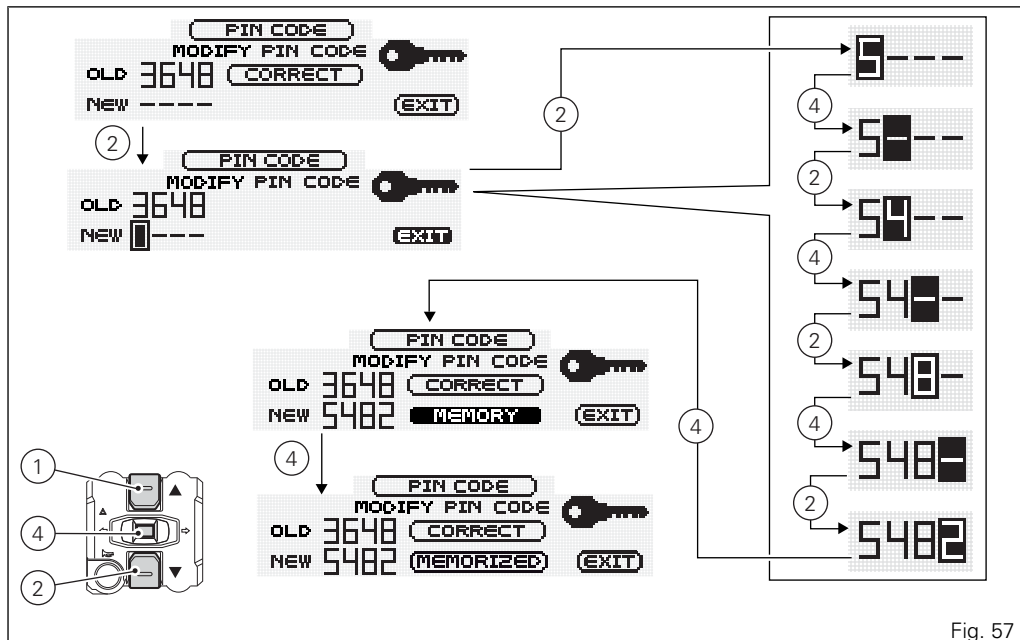

Fig. 57

The Immobilizer system

For improved antitheft protection, the motorcycle is equipped with a IMMOBILIZER, an electronic system that inhibits engine operation whenever the ignition switch is turned off.

Accommodated in the handgrip of each ignition key is an electronic device that modulates an output signal. When the ignition is turned on this signal is generated by a special antenna incorporated in the switch and changes every time.

The modulated signal acts as a password (which is different at each start-up) and tells the ECU that an "authorised" ignition key is being used to start up the engine. When the ECU recognises the signal, it enables engine start-up.

Keys

The owner receives 2 keys B (BLACK) with the vehicle.

These keys contain the "immobilizer system code".

The black keys (B) are regular ignition keys and are used to:

- start up the engine.
- open the fuel tank filler plug.
- open the seat lock.



Warning

Separate the keys and use only one of the black keys to start the motorcycle.

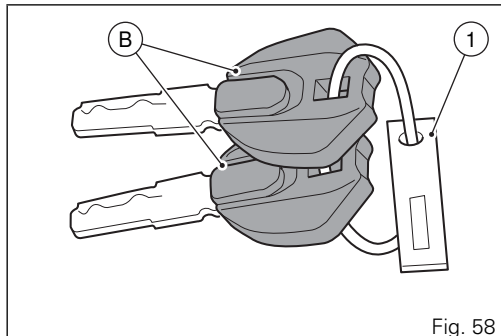

Fig. 58

Entering PIN CODE function for vehicle release

This function provides vehicle temporary starting in the event of an engine lock due to the Immobilizer system malfunctioning.

If upon Key-On a Immobilizer ERROR is present, the instrument panel will automatically enable the PIN entering function.

Entering the code:

- each time you press button (2), the highlighted number increases from 0 to 9 and back to 0, press button (4) to confirm;
- repeat this procedure until entering the fourth digit.
- Press button (4) again to confirm.

If code is wrong, the instrument panel will display the "WRONG" indicator for 2 seconds and then will display again the starting indicator to repeat the PIN code entering procedure.

If code was correctly entered, the instrument panel will display the "CORRECT" indicator for 2 seconds. After this time, the instrument panel will go back to the standard display (with all indicators active).



Note

PIN code entering can be repeated as many times as you want; nevertheless, instrument panel will automatically turn off 120 seconds after attempting to enter the PIN code and the "TIME OUT" indicator will be displayed for 2 seconds. Instrument panel will then go back to the main page.

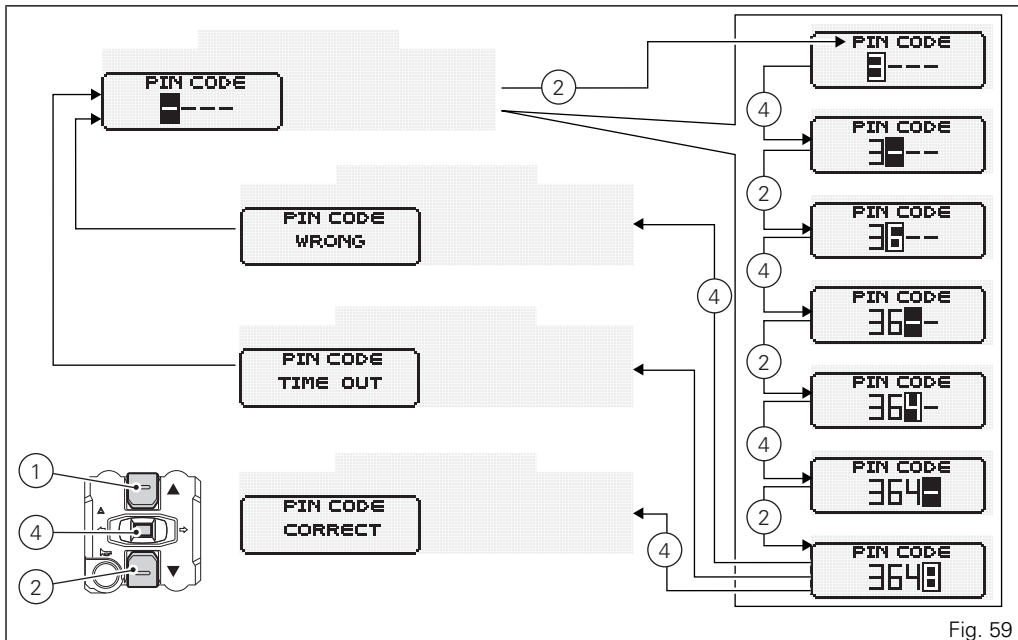

Fig. 59

From now on, vehicle can be started with button (5).



Note

The vehicle can be started until a Key-Off is performed; if the problem still persists upon the next starting attempt, repeat the procedure from the beginning in order to start the motorcycle "temporarily".



Important

If this procedure is necessary in order to start the vehicle, contact an Authorised Ducati Service Centre as soon as possible to fix the problem.

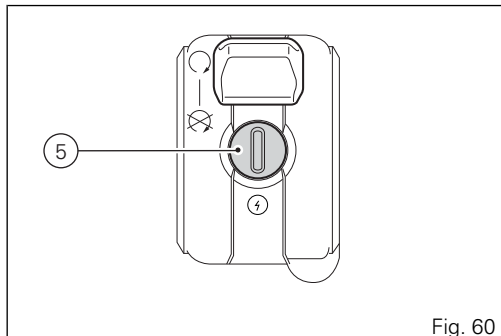

Fig. 60

Operation

When the ignition key is turned to OFF, the immobilizer inhibits engine operation.

When the ignition key is turned back to ON to start the engine, the following happens:

- 1) if the code is recognised, the immobilizer enables engine ignition. Press the START button (5), to start the engine;
- 2) if code is not recognised, the instrument panel will automatically activate the PIN entering function. Refer to the PIN code Entering procedure to unlock the vehicle. If the other key does not work out either, contact the Ducati Service network.

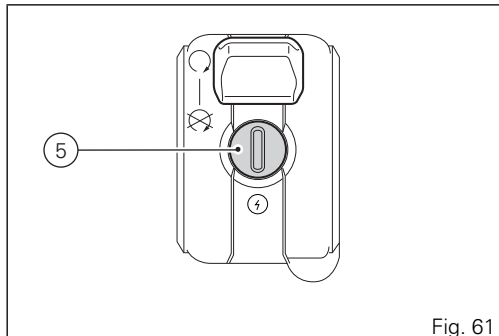

Fig. 61



Warning

Any important shock might damage the electronic components fitted into the key. Use only one key during the procedure. Using different keys could prevent the system from recognising the code in the key.

Duplicate keys

If you need any duplicate keys, contact the Ducati Service network with all the keys you have left.

The Ducati Service Centre will program all the new keys as well as any keys you already have.

You may be asked to provide proof that you are the legitimate owner of the motorcycle.

The codes for any keys not present during the memory programming procedure are cancelled, to ensure that any keys that may have been lost can no longer be used to start the engine.



Note

If you sell your motorcycle, do not forget to give all keys to the new owner.

Light control

Headlight control

This function allows you to reduce current consumption from the battery, by automatically managing headlight switching-off.

At Key-On, the high beam and low beam lights are off. As soon as engine is started, low beams will be automatically turned on; from now on, "standard" operation will be active, i.e. whenever button (3) is pressed, it will be possible to switch from low beams to high beams with button (3) in position (V) or "FLASH" with button (3) in position (O). If engine is not started upon Key-On, lights can nevertheless be activated by pressing LH high/low beam switch:

When button is pressed the "first" time, low beams will be turned on; from now on this button can be used to turn high beams on or off: if engine is not started within 60 seconds, low and high beams will be turned Off.

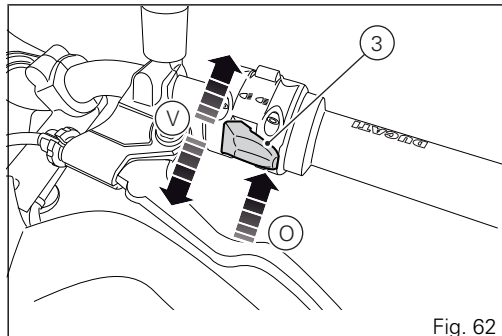

If the headlight was turned on before starting the engine with the procedure described above, the headlight turns off automatically when starting the vehicle and will turn on again when the engine has been completely started.

Turn indicators (automatic reset)

Turn indicators are automatically reset by the instrument panel.

After activating one of the two turn indicators, they can be deactivated using the reset button (4). If the turn indicator is not "reset" manually, the instrument panel will automatically switch it off after the motorcycle has travelled 500 m (0.3 miles) from when the turn indicator was activated.

The counter for the distance travelled for automatic deactivation is activated at speeds below 80 Km/h (50 mph).

If the calculation of the distance for automatic deactivation is activated and then the motorcycle exceeds a speed of 80 km/h (50 mph), the calculation is interrupted and will restart when the speed returns below the indicated threshold.

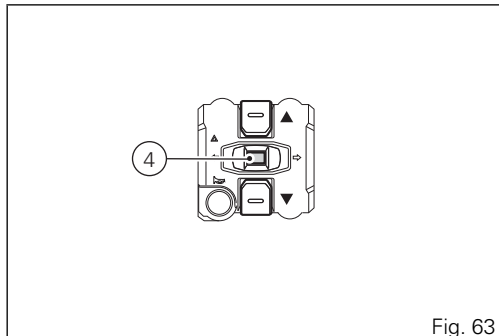

Hazard

All the turn indicators can be turned on together (Hazard function) as emergency indicator.

To enable the Hazard function (4 turn indicators) keep the button generally used to activate LH turn indicator (button (4) in position (6)) pressed for 3 seconds.

The Hazard function can be enabled during Key-On only (and not Key-Off).

When the Hazard function is active, both warning lights (7) on the instrument panel will flash at the same time.

To disable the hazard function, namely to turn all 4 turn indicators off, simply press the button generally used to activate the LH turn indicator (button (4) in position (6)) or press the turn indicator cancel button (button (4) in central position).

The Hazard function can be disabled also during Key-Off by pressing just once the button generally used to activate the LH turn indicator (button (4) in position (6)).

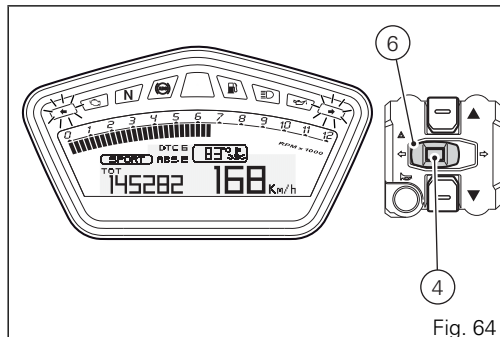

Fig. 64

After the Hazard function has been enabled, if ignition switch is turned from On to Off, the 4 turn indicators will remain active and turn automatically off after 120 minutes (2 hours), unless "manually" turned off: in this case the automatic count-down will be interrupted.

Units of measurement modification function (UNITS)

This function allows you to change the units of measurement of the displayed values.

To display this function, access the Setting Menu and select the "UNITS" page.

The instrument panel displays the values that can be changed (Speed, Temperature or Consumption); use buttons (1) and (2) to select the value you want to change, and press button (4) again.



Note

When the default settings are active, a symbol (circle with a dot) is always displayed close to the DEFAULT indicator.

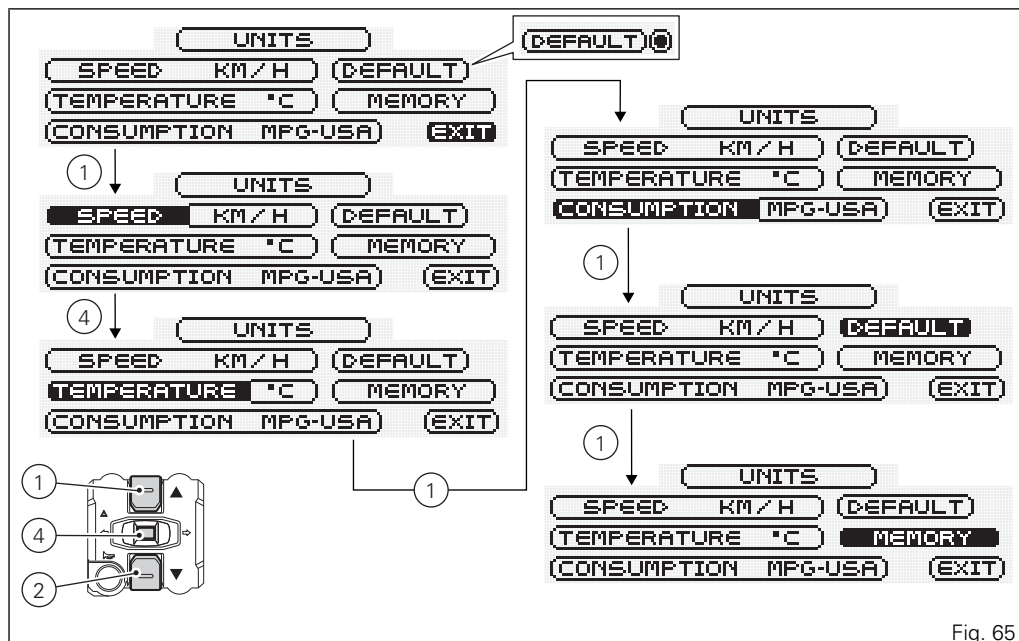

Fig. 65

Setting (SPEED)

This function allows changing the units of measurement of the following indicators: Vehicle speed, Odometer, Trip 1, Trip2, Trip Fuel (when active) and Average Speed.

Once the "SPEED" indicator is selected, press button (4).

The instrument panel will display the Unit of measurement being used. Press buttons (1) or (2) to scroll the available units of measurement (Km/h and mph). Once you have selected the units of measurement you want to set, press button (4) again. The instrument panel will automatically highlight the "MEMORY" indicator; to store the new unit of measurement, keep button (4) pressed for 3 seconds.

After this time, the instrument panel will display the "MEMORIZED" indicator for 2 seconds as a confirmation of the change made.

The "EXIT" indicator will be automatically highlighted; press button (4) to quit this page and go back to the setting menu.

KM/H: if this option is set, the following values will have the same units of measurement:

- TOT, TRIP1, TRIP2, TRIP FUEL: Km
- Vehicle Speed and SPEED AVG: Km/h

MPH: if this option is set, the following values will have the same units of measurement:

- TOT, TRIP1, TRIP2, TRIP FUEL: miles
- Vehicle Speed and SPEED AVG: mph



Note

When the default settings are active, a symbol (circle with a dot) is always displayed close to the DEFAULT indicator.

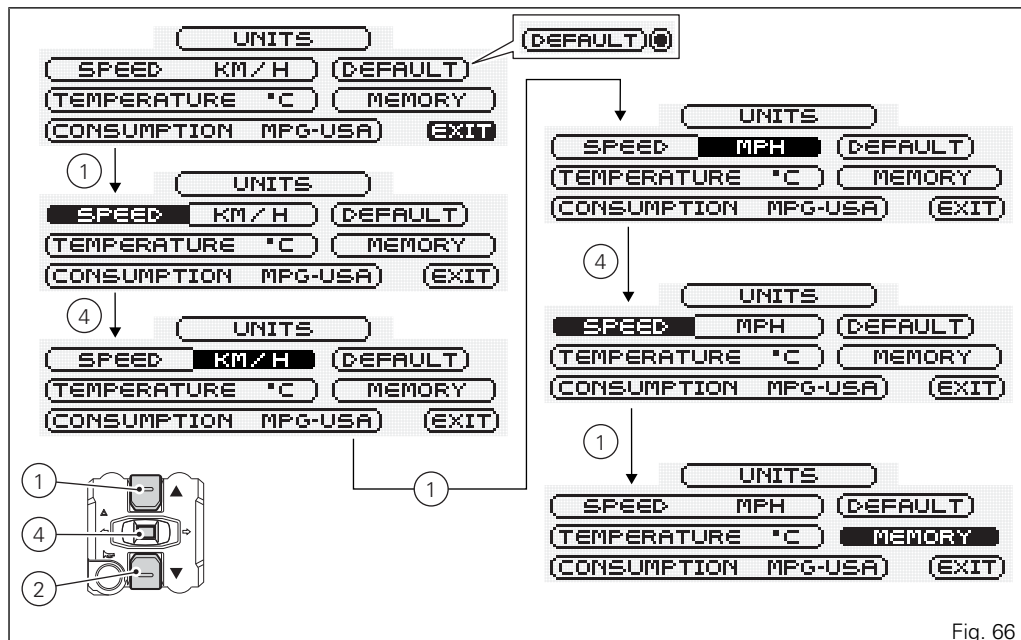

Fig. 66

Setting (TEMPERATURE)

This function allows changing the units of measurement of the following indicators: Engine coolant temperature and Air Temperature.

Once the "TEMPERATURE" indicator is selected, press button (4). The instrument panel will display the Unit of measurement being used.

Press buttons (1) or (2) to scroll the available units of measurement (°C and °F). Once you have selected the units of measurement you want to set, press button (4) again.

The instrument panel will automatically highlight the "MEMORY" indicator; to store the new unit of measurement, keep button (4) pressed for 3 seconds; after this time, the instrument panel will display the "MEMORIZED" indicator for 2 seconds as a confirmation of the change made.

The "EXIT" indicator will be automatically highlighted; press button (4) to quit this page and go back to the setting menu.

°F: if this option is set, the following values will have the same units of measurement:

- Engine coolant temperature and T_AIR: °C

°F: if this option is set, the following values will have the same units of measurement:

- Engine coolant temperature and T_AIR: °F



Note

When the default settings are active, a symbol (circle with a dot) is always displayed close to the DEFAULT indicator.

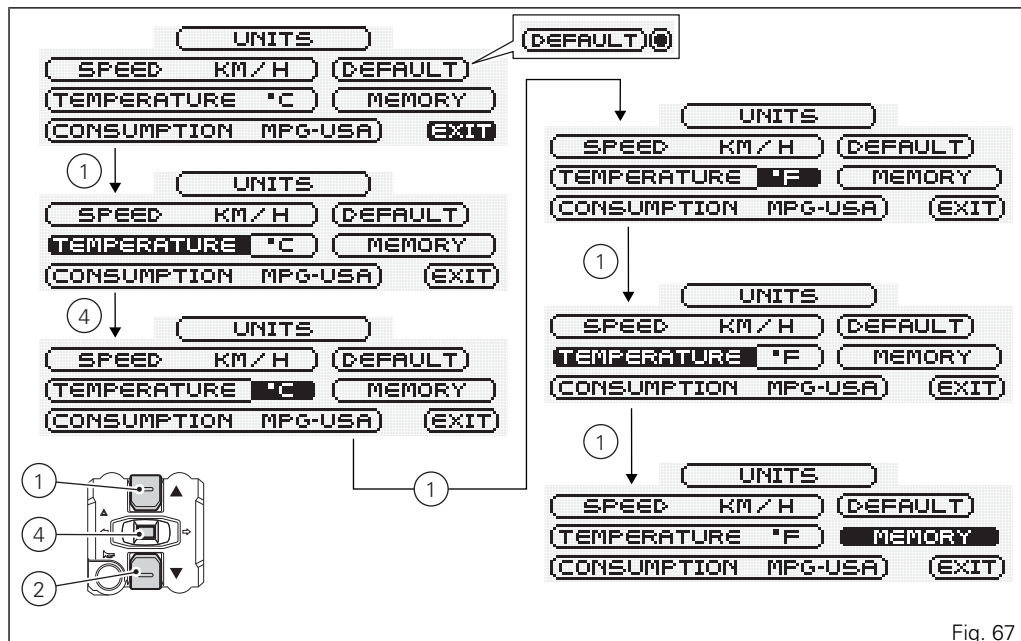

Fig. 67

Setting (CONSUMPTION)

This function allows changing the units of measurement of the following indicators: Average Consumption and Instantaneous Consumption. Once the "CONSUMPTION" indicator is selected, press button (4). The instrument panel will display the Unit of measurement being used. Press buttons (1) or (2) to scroll the available units of measurement (L/100, KM/L, MPG-UK and MPG-USA).

Once you have selected the units of measurement you want to set, press button (4) again. The instrument panel will automatically highlight the "MEMORY" indicator; to store the new unit of measurement, keep button (4) pressed for 3 seconds; after this time, the instrument panel will display the "MEMORIZED" indicator for 2 seconds as a confirmation of the change made. The "EXIT" indicator will be automatically highlighted; press button (4) to quit this page and go back to the setting menu.

L/100: if this option is set, the following values will have the same units of measurement:

- CONS. and CONS AVG : Km/L

L/100: if this option is set, the following values will have the same units of measurement:

- CONS. and CONS AVG : L/100

MPG UK: if this option is set, the following values will have the same units of measurement:

- CONS. and CONS AVG : mpgal UK

MPG USA: if this option is set, the following values will have the same units of measurement:

- CONS. and CONS AVG : mpgal USA



Note

When the default settings are active, a symbol (circle with a dot) is always displayed close to the DEFAULT indicator.

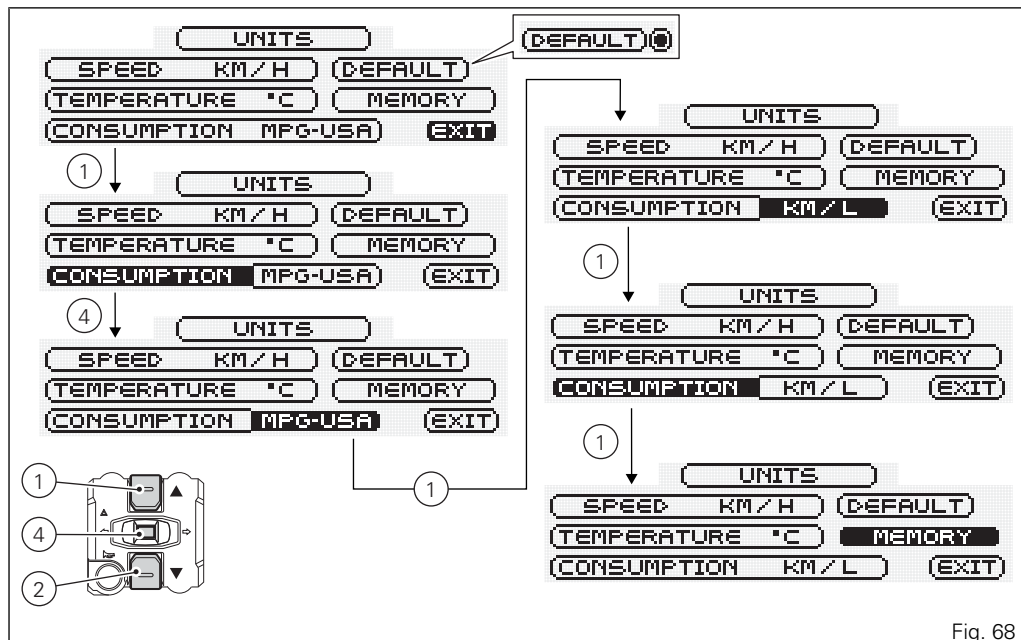

Fig. 68

Setting (DEFAULT)

This function allows setting the "DEFAULT" units of measurement based on vehicle version. Select the "DEFAULT" indicator with buttons (1) and (2), then keep button (4) pressed for 3 seconds. Now the "ALL DEFAULT" wording will be replaced by the "PLEASE WAIT..." indicator, which will be displayed for 3 seconds to inform the user that the instrument panel is restoring the default units of measurement. After 3 seconds, all the indicated units of measurement will be updated and the "EXIT" indicator will be automatically highlighted; press button (4) to quit this function and go back to the setting menu.



Note

When the default settings are active, a symbol (circle with a dot) is always displayed close to the DEFAULT indicator.

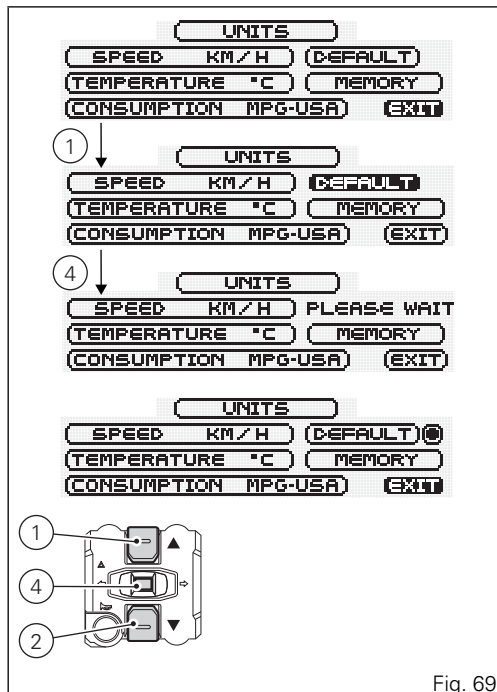

Fig. 69

DEFAULT based on vehicle version

	TOT, TRIP1, TRIP2 TRIP FUEL	SPEED AVERAGE SPEED	T_ENGINE T_AIR	INSTANTANEOUS CON- SUMPTION AVERAGE CON- SUMPTION
Europe	Km	km/h	°C	l/100km
UK	miles	mph	°C	mpg UK
USA	miles	mph	°F	mpg USA
Canada	km	km/h	°C	l/100km
France	km	km/h	°C	l/100km
Japan	km	km/h	°C	l/100km
Brazil	km	km/h	°C	l/100km
Taiwan	km	km/h	°C	l/100km
China	km	km/h	°C	l/100km

Other functions

UP-MAP function

This function is used to provide a user's interface while the Performance calibration is downloaded from the UP-MAP device (key) to the engine control unit during Performance exhaust kit (part no. 96480031A) and Performance silencer kit (part no. 96480051A) assembling.



Note

Performance exhaust kit (part no. 96480031A) and Performance silencer kit (part no. 96480051A) can be purchased at a Ducati Dealer or authorised Service Centre.



Warning

To fit Performance exhaust kit (part no. 96480031A) and Performance silencer kit (part no. 96480051A) contact a Ducati Dealer or authorised Service Centre.

The UP-MAP device can be used only with powered vehicle (key-on) and engine off. When the UP-MAP is connected to the vehicle, these conditions are

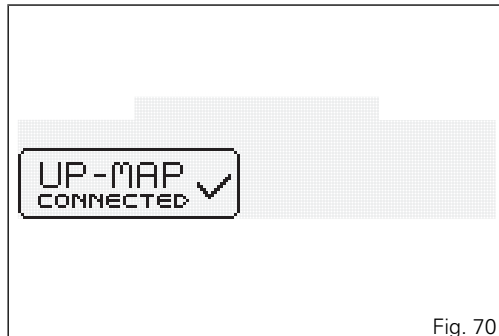

Fig. 70

checked and, if they are all verified, the UP-MAP, engine control unit and instrument panel will start communicating. The "UP-MAP CONNECTED" wording will be displayed to indicate that the UP-MAP device is connected to the system.

If the device authentication is not successful, the indication "UP-MAP NOT COMPATIBLE" is displayed for 3 seconds, and then display will read "UNPLUG UP-MAP" to urge the user to remove the device from the vehicle.

As soon as the UP-MAP device is disconnected from vehicle, the "PLEASE WAIT..." indicator will be displayed for 3 seconds.

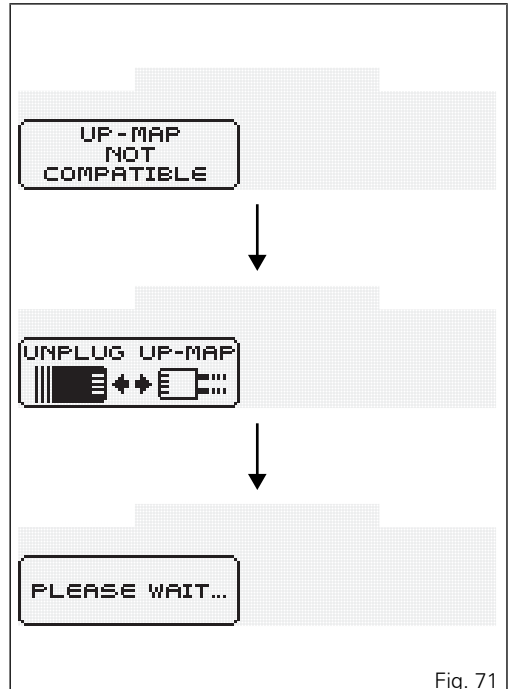

Fig. 71

If not, the procedure to check that the conditions required for download will continue.

If the download can be carried out, the map name is displayed and the "DOWNLOAD" indicator is highlighted. Press button (4) to download the indicated calibration.

The maps available for download are:

- RACING 01 MAP for Performance silencer calibration;
- RACING 02 MAP for complete Racing kit calibration.

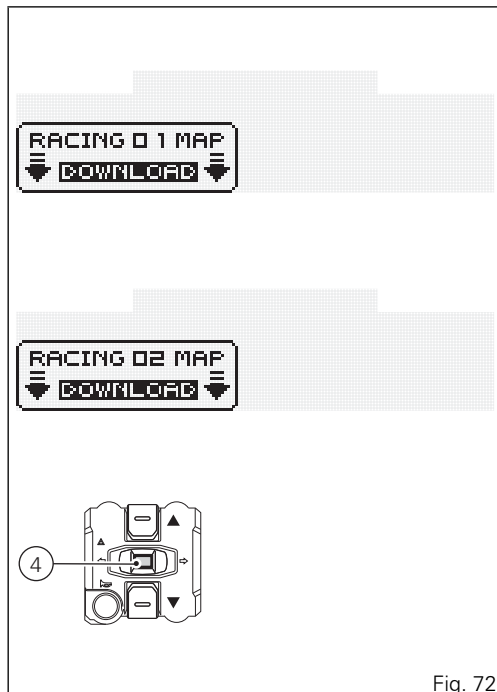

Fig. 72

If download cannot be executed and the calibration to be downloaded is already present, the "MAP ALREADY PRESENT" indicator and "EXIT" indicator will be displayed. Press button (4) to quit. After button (4) is pressed, or after 10 seconds without pressing button (4), the "UNPLUG UP-MAP" indicator will be displayed to inform the user to disconnect device from vehicle. As soon as the UP-MAP device is disconnected from vehicle, the "PLEASE WAIT..." indicator will be displayed for 3 seconds.

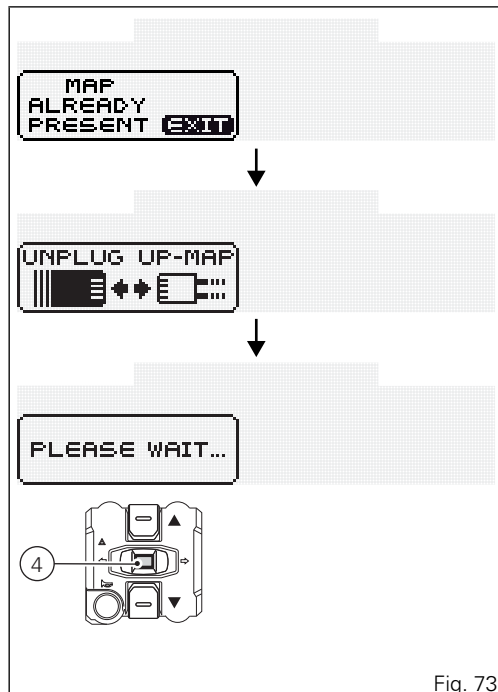

Fig. 73

During download, the name of the map, the "WAIT....." indicator and the progressive download bar will be displayed for approx. 5 seconds. Once download is completed, the "COMPLETED" indicator will be displayed for 3 seconds, and the download bar will be full.

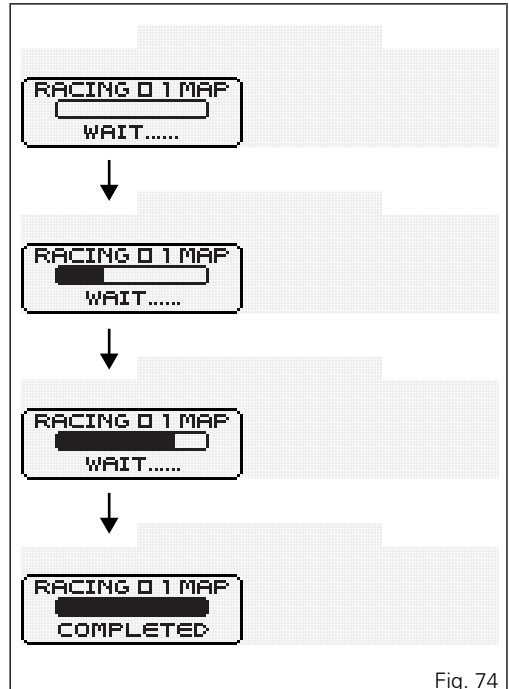

Fig. 74

After 3 seconds, if the whole process was successful, the display will read "UNPLUG UP-MAP" to urge the user to remove the device from the vehicle.

The "UNPLUG UP-MAP" indicator will be displayed until the UP-MAP is physically disconnected from vehicle.

After device disconnection, the "PLEASE WAIT...." indicator will be displayed for 3 seconds, then the standard screen view will appear again.

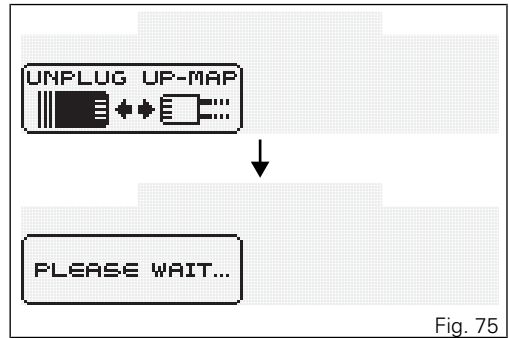

Fig. 75

Any time a malfunction of the UP-MAP is found or the download procedure is not successful, the instrument panel displays "DOWNLOAD ABORTED" for 3 seconds, and then the indication "UNPLUG UP-MAP".

As soon as the UP-MAP device is disconnected from bike, the "PLEASE WAIT..." indicator will be displayed for 3 seconds.



Note

In case of accidental key-off or disconnection of the UP-MAP before the download is completed, the procedure is considered not valid.



Note

When the UP-MAP is connected to the vehicle, engine starting is inhibited. It is not possible to ride the vehicle with the UP-MAP device connected.

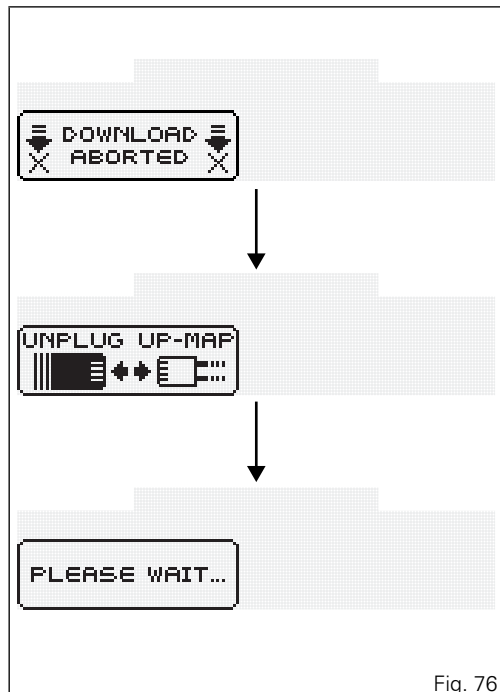

Fig. 76

Heated Grip control function (Accessory)

This function allows enabling and adjusting heated grips. To open heated grips "H.GRIPS" control menu, press button (5) on RH switch. Control button (5) (Start button) will be used to control heated grips when engine is started, only. Once menu is enabled, press several times the same button to select the desired indication (OFF, LOW, MIDDLE and HIGH). If OFF is selected, heated grips are disabled, if LOW is selected, heated grips lowest heat level is enabled, if MIDDLE is selected, heated grips middle heat level is enabled; if HIGH is selected, heated grips highest heat level is enabled.

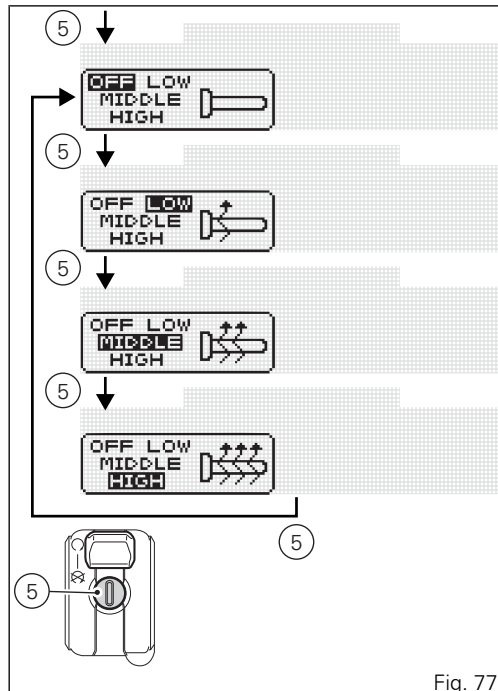

Fig. 77

Once the desired heat level is selected, do not further press button (5); after 3 seconds the instrument panel will automatically quit this function and the last condition will be stored.



Note

Heated grips are actually enabled, namely produce heat, only with the engine running and above 2,000 RPM.

If, for example, heated grips are enabled and then engine is turned off, they will be temporarily disabled. They will be automatically re-enabled once engine is started again.

Grip heating requires a high current draw which could run the battery flat at low RPM.

If battery charge is not enough (voltage below 11.0 Volt) grip heating will be disabled to ensure vehicle starting; it will be automatically re-enabled as soon as battery voltage is above the indicated value.



Warning

If heated grips are used at ambient temperatures above 15° ÷ 20° C, heat will be automatically reduced (based on outer temperature) to protect grips against any damage due to overheating.

Controls

Position of motorcycle controls



Warning

This section shows the position and function of the controls used to ride the motorcycle. Be sure to read this information carefully before you use the controls.

- 1) Instrument Panel.
- 2) Key-operated ignition switch and steering lock.
- 3) LH switch.
- 4) Clutch lever.
- 5) Rear brake pedal.
- 6) RH switch.
- 7) Throttle twistgrip.
- 8) Front brake lever.
- 9) Gear change pedal.

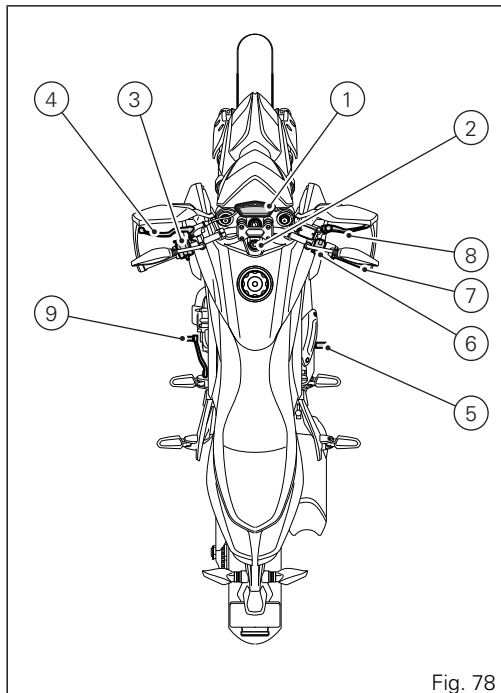

Fig. 78

Ignition switch and steering lock

It is located in front of the fuel tank and has four positions:

- A) ON: enables lights and engine operation;
- B) OFF: disables lights and engine operation;
- C) LOCK: the steering is locked;
- D) P: parking light on and steering locked.

Note

To move the key to the last two positions, press it down before turning it. The key can be removed in positions (B), (C) and (D).

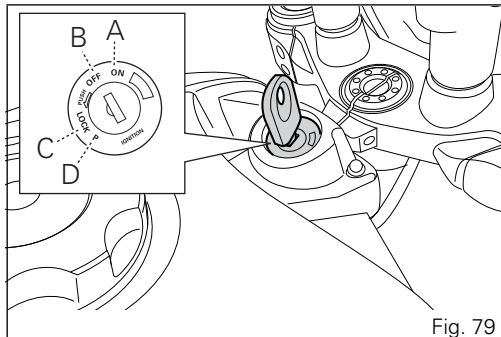







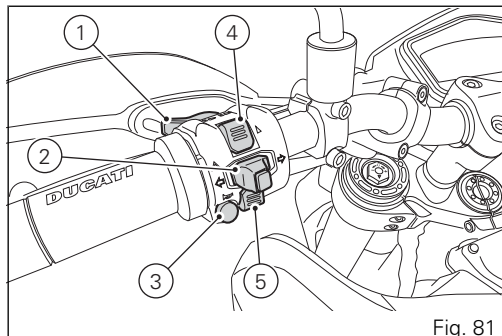
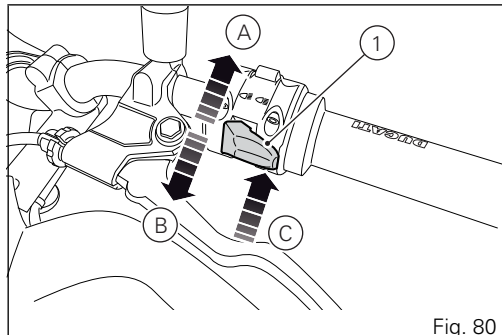

Fig. 79

Left-hand switch

- 1) Dip switch, two-position light selector switch:
position  = low beam on (A);
position  = high beam on (B);
Button  = high-beam flasher (FLASH) and instrument panel control (C).
- 2) Switch  = three-position turn indicator:
centre position = off;
position  = left turn;
position  = right turn.
To cancel the turn signal, press the lever once it has returned to the central position.
- 3) Button  = warning horn.
- 4) Instrument panel control button "▲" position.
- 5) Instrument panel control button "▼" position.



Clutch lever

Lever (1) disengages the clutch. When the clutch lever (1) is operated, drive from the engine to the gearbox and the drive wheel is disengaged. Using the clutch properly is essential to smooth riding, especially when moving off.



Important

Using the clutch properly will avoid damage to transmission parts and spare the engine.



Note

The engine can be started with the side stand down and the gearbox in neutral. If starting with a gear engaged, pull in the clutch lever (in this case the side stand must be up).

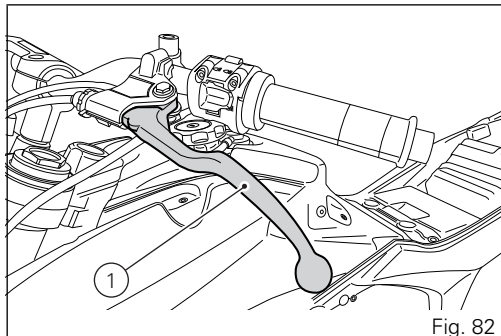

Fig. 82

Clutch control free play adjustment



Warning

A wrong adjustment may severely affect clutch operation and life.

When worn, clutch stretches clutch cable.

Always check clutch free play, with the engine cold, before riding the vehicle.

When operating clutch, you must clearly feel the shift from a very low force required to pull the lever to quite a stronger one (working force).

Free play corresponds to the lever stroke at which resistance force is kept at a very low level.

Operate lever so as to cover its free play, and make sure that distance "A" is between 3 and 4 mm.

To restore recommended free play value, make sure that free play is not equal to zero. Work on primary adjuster (2) close to clutch control.

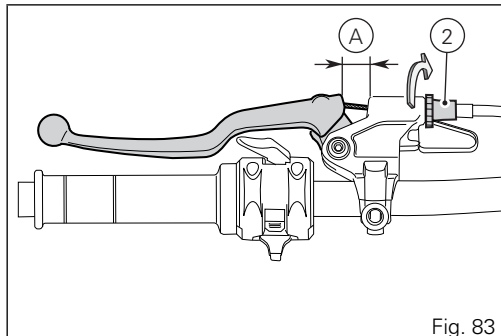
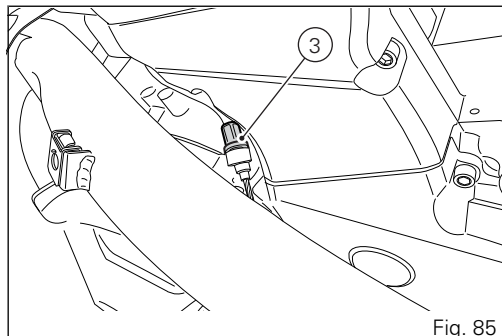
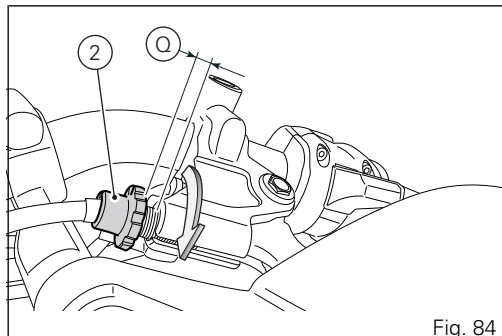

Fig. 83

Adjuster (2), positioned onto lever, allows a max. adjustment (Q) of 11 mm, while standard (starting) adjustment is equal to 5 mm. Should this adjuster not be enough to restore lever free play, work on secondary adjuster (3).

Warning

In case of clutch slipping due to excessive wear, lever adjuster (2) **MUST NEVER** be loosened, but screwed-in, as specified above. Should clutch continue to slip, contact a Ducati Dealer or Authorised Workshop.



Right-hand switch

- 1) Red ON/OFF switch.
- 2) Black ENGINE START button

The switch (1) has three positions:

- A) centre: RUN OFF. In this position, the engine cannot be started and all electronic devices are off.
- B) pushed down: ON/OFF. In this position, the system can be turned on (Key-On) and off (Key-Off).
- C) pushed up: RUN ON. The engine can only be started in this position, pushing the black button (2).

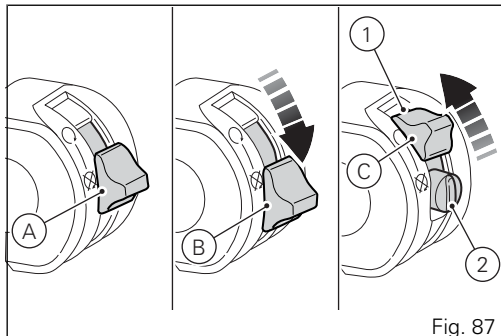
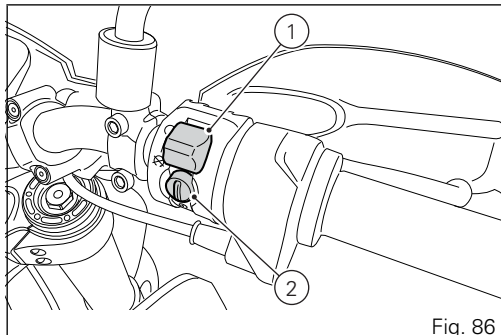

Throttle twistgrip

The twistgrip (1) on the right handlebar opens the throttles. When released, it will spring back to the initial position (idling speed).

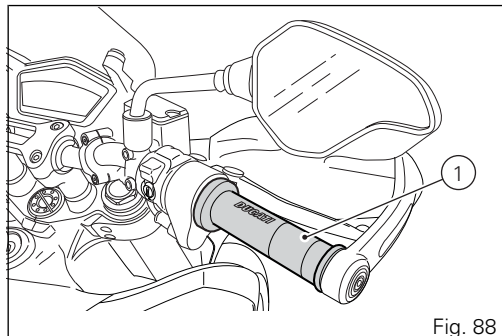

Front brake lever

Pull in the lever (1) towards the twistgrip to operate the front brake. The system is hydraulically operated and you just need to pull the lever gently. The brake lever has a wheel (2) for adjusting the distance between lever and twistgrip on the handlebar. To adjust it, keep lever (1) fully extended and turn knob (2) in one of the five positions. Position no. 1 corresponds to the max. distance between lever and knob, while position no. 5 corresponds to the min. distance.



Warning

The front brake lever must be adjusted when the motorcycle is stationary.

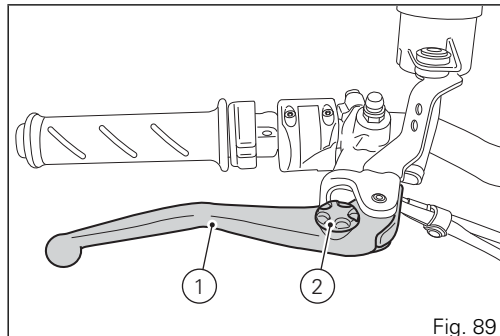

Fig. 89

Rear brake pedal

Push down on the pedal to apply the rear brake (1).
The system is hydraulically operated.

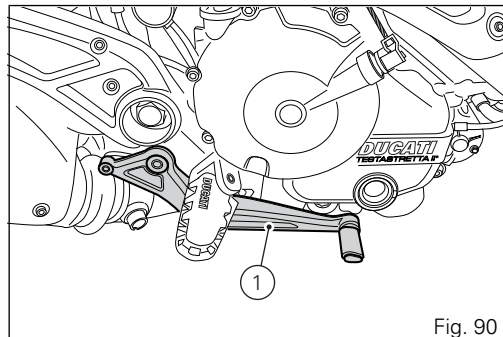

Fig. 90

Gear change pedal

When released, the gear change pedal automatically returns to rest position N in the centre. This is indicated by the instrument panel light N coming on. The pedal can be moved:

- down = press down the pedal to engage the 1st gear and to shift down. The N light will go out;
- upwards= lift the pedal to engage 2nd gear and then 3rd, 4th, 5th and 6th gears.

Each time you move the pedal you will engage the next gear.

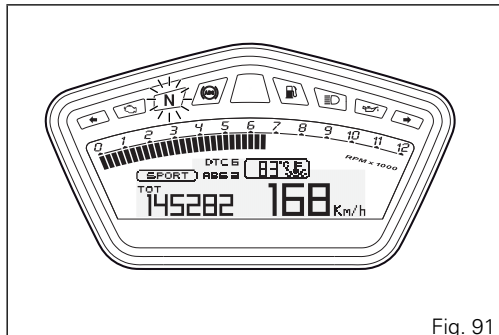

Fig. 91

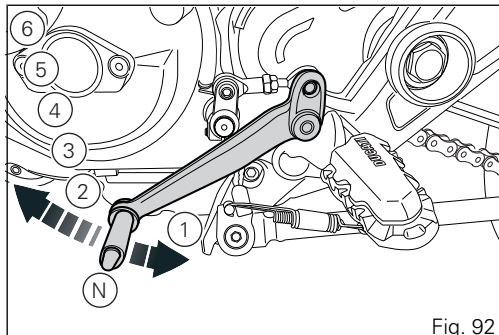

Fig. 92

Adjusting the position of the gearchange and rear brake pedals

The position of the gearchange and rear brake pedals in relation to the footrests can be adjusted to suit the requirements of the rider.

Adjust the pedals as follows:

Gear change pedal

Use an open ended spanner to hold the spherical end on the rod (1) on the flat (2) and loosen the counter nut (3).

Turn the screw (4) to detach the rod completely from the gear change lever.

Turn the rod (5), until the gear change pedal is set to the desired position.

Tighten the screw (4) to secure the gearchange lever to the rod (5).

Tighten the lock nut (3) onto the ball joint (1).

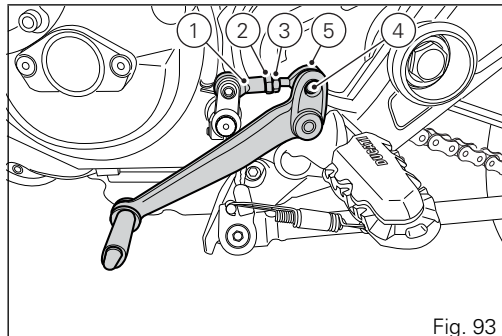

Rear brake pedal.

Loosen counter nut (7).

Turn pedal stroke adjusting screw (6) until pedal is in the desired position. Tighten the counter nut (7).

Operate the pedal by hand to check that there is 1.5 to 2 mm of freeplay before the brake bites. If not, check to modify the length of the cylinder push-rod in the following mode.

Slacken off the counter nut (10) on the pushrod.

Screw the pushrod (8) into the fork (9) to increase the free play, or screw it out to reduce it.

Tighten the counter nut (10) and recheck the pedal freeplay.

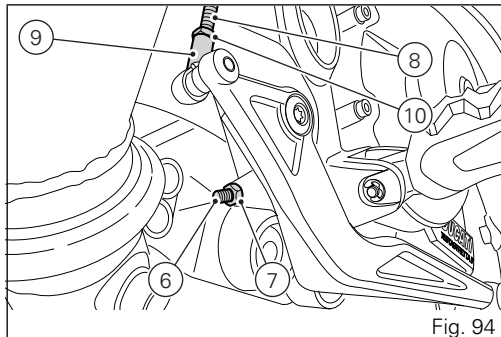

Fig. 94

Main components and devices

Position on the vehicle

- 1) Tank filler plug.
- 2) Seat lock.
- 3) Side stand.
- 4) Rear-view mirrors.
- 5) Front fork adjusters.
- 6) Rear shock absorber adjusters.
- 7) Catalytic converter.
- 8) Exhaust silencer.

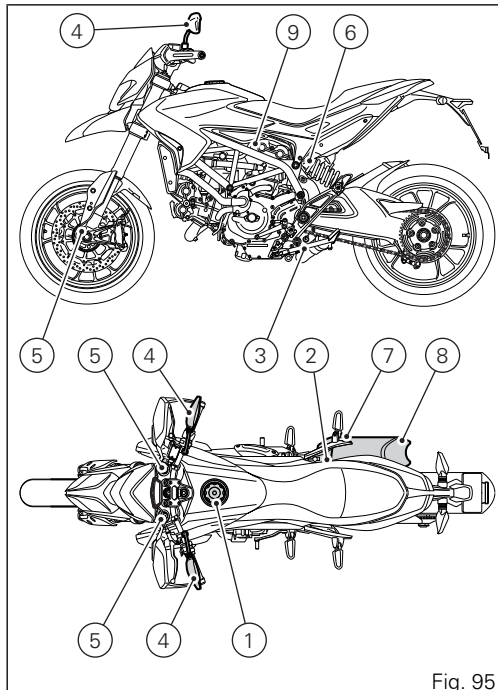

Fig. 95

Tank filler plug

Opening

Insert the key into the lock.

Turn the key clockwise 1/4 turn to unlock.

Unscrew the plug (1).

Closing

Tighten the plug (1) with the key inserted and push it down into its seat.

Turn the key counter-clockwise to the initial position and remove it.



Note

The plug can only be closed with the key in.



Warning

Always make sure you have properly refitted and closed the plug after refuelling.

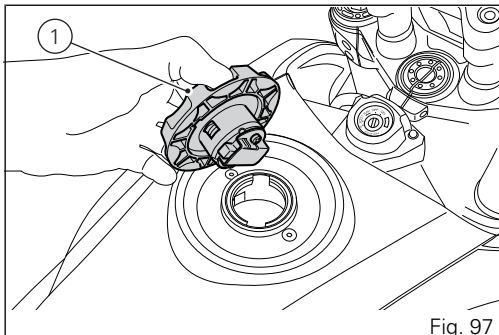
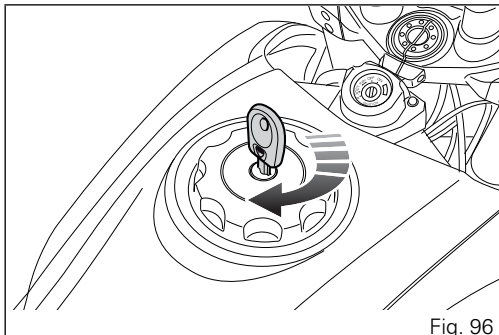

Seat lock

Opening

Insert the key (1) in the lock, turn it clockwise, and simultaneously press down in the area of the catch to release the pin.

Pull the seat (2) backwards to release it from the front catches.

Closing

Make sure all parts are correctly arranged and secured in the underseat compartment.

Insert underseat plate front ends (A) under tank seats (B).

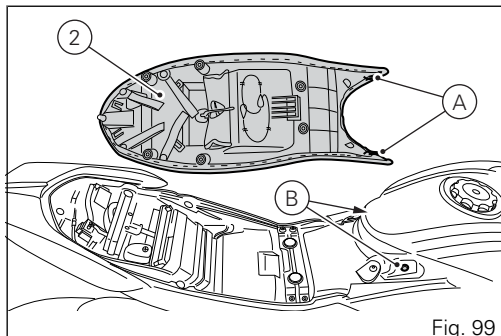
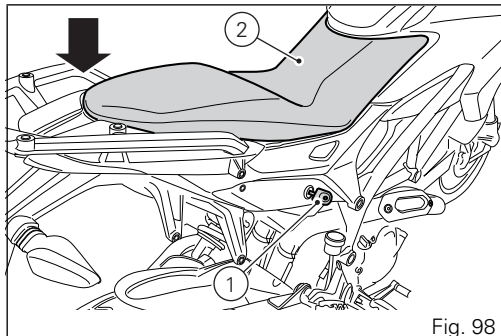

Keep seat back side (2) raised and press onto central fastener to fix it in place.
Press seat back side (2) until lock latch clicks in place.
Make sure that the seat is firmly secured to the frame and remove the key (1) from the lock.

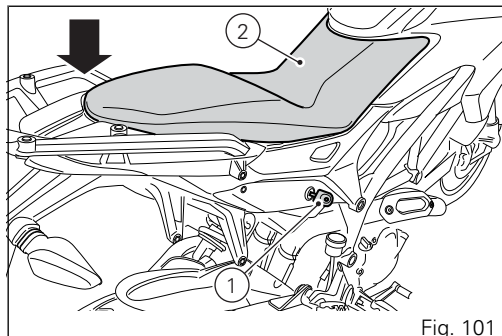
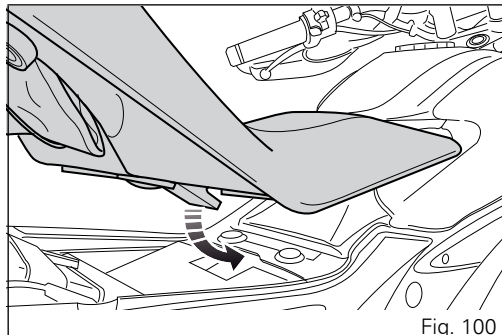

Helmet cable

Remove seat as described in paragraph "Seat Lock page 148" .

Remove cable (1) from seat.

Pass the cable (1) through the helmet and insert the ends of the cable in the frame pin (2).

Leave the helmet hanging and refit the seat to hold it in place.



Warning

This device protects the helmet against theft when the motorcycle is parked. Do not leave the helmet attached when riding the motorcycle; it could interfere with your movements and cause loss of control of the motorcycle.

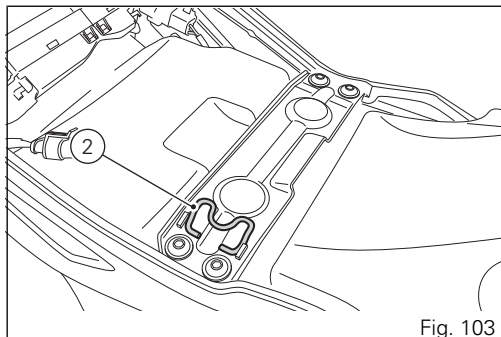
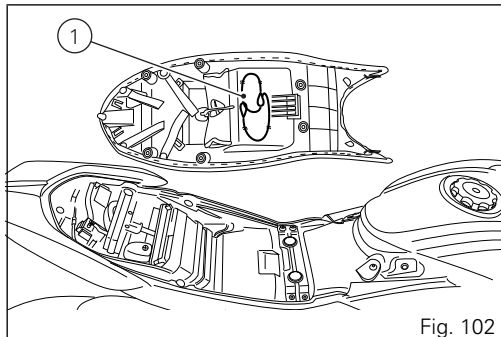

Side stand

Important

Use the side stand to support the motorcycle only during short stops. Before lowering the side stand, make sure that the bearing surface is hard and flat.

Do not park on soft or pebbled ground or on asphalt melt by the sun heat and similar or the motorcycle may fall over. When parking in downhill road tracts, always park the motorcycle with its rear wheel facing downhill.

To pull down the side stand, hold the motorcycle handlebars with both hands and push down on the side stand (1) with your foot until it is fully extended. Tilt the motorcycle until the side stand is resting on the ground.

To move the side stand to its rest position (horizontal position), lean the motorcycle to the right while lifting the thrust arm (1) with your foot.

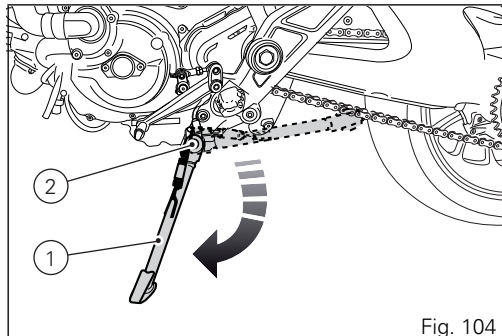

Warning

Do not sit on the motorcycle when it is supported on the side stand.

Note

Check for proper operation of the stand mechanism (two springs, one inside the other) and the safety sensor (2) at regular intervals.

Adjusting the front fork

The front fork used on this motorcycle has rebound, compression and spring preload adjustment.

The adjustment is carried out by means of the outer adjusters:

- 1) to adjust the rebound damping (right leg);
- 2) to adjust internal spring preload (both legs);
- 3) to adjust the compression damping (left leg).

Put the motorcycle on the side stand and make sure it is stable. Use a flat head screwdriver on the right leg adjuster (1) to adjust the rebound damping. Use a flat head screwdriver on the left leg adjuster (3) to adjust the compression damping. To adjust fork leg inner spring preload, turn hex. head adjuster (2) using a 22 mm hexagon wrench. While turning adjusters (1 and 3), you can hear some clicks: each click correspond to a damping adjustment. Position "0", corresponding to max. damping, can be reached by screwing adjuster all the way in until it locks in place.

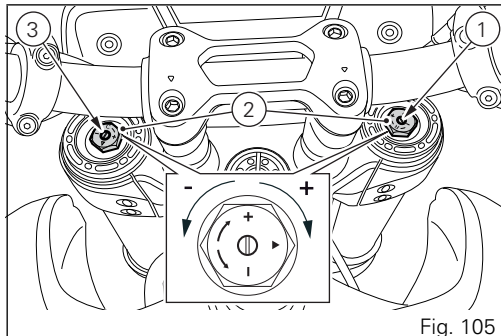

Fig. 105

Starting from this position, turn counter-clockwise and count the clicks that correspond to positions "1", "2", etc..

STANDARD adjustment values are:

- compression: 14 clicks from Max. (completely closed);
- rebound: 14 turns from Max. (completely closed);
- spring preload: plus 5 turns from Min. (all unpreloaded).

Each complete turn corresponds to 1 mm of spring preload (total 10 mm).



Warning

Set both leg adjusters on the same positions.

Adjusting the rear shock absorber

The rear shock absorber has commands that enable you to adjust the setting to suit the load on the motorcycle. The knob (1), located on the expansion reservoir, controls the compression damping. The knob (3), located near the shock absorber to swingarm upper fastener, controls rebound damping. Turn knobs (1) or (3) clockwise to increase damping, or counter-clockwise to reduce damping. Two ring nuts (2) located on the lower section of the shock absorber are used to adjust the outer spring preload. To change spring preload, slacken off the upper ring nut. Then TIGHTEN or SLACKEN the lower ring nut to INCREASE or DECREASE spring preload.

STANDARD setting from the fully closed position (clockwise):

- rebound: unscrew the adjuster (1) by 16 clicks from Max (fully closed);
- compression: unscrew the adjuster (3) by 10 clicks from Max (fully closed);
- spring preload: 7 mm from Min. (all unpreloaded).

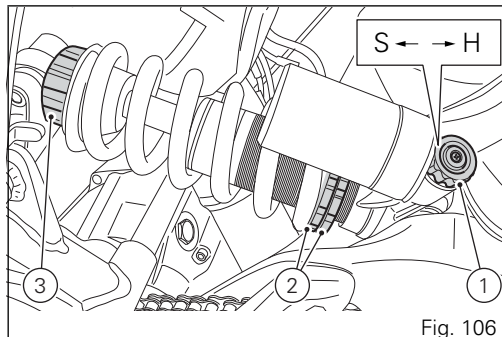

Warning

Use a specific pin wrench to turn the preload adjusting nut. Be careful when turning the nut with the wrench, as the pin may slip out of the ring nut recess and you may hurt your hand hitting motorcycle parts.



Warning

The shock absorber is filled with gas under pressure and may cause severe damage if taken apart by unskilled persons.

Once the desired preload has been set, tighten the upper locking ring nut.

When carrying a passenger and luggage, set the rear shock absorber spring to proper preload to improve motorcycle handling and keep safe clearance from the ground. You may find that rebound damping needs adjusting as well. The shock absorber is adjusted by electric impulses sent by the instrument panel to the adjusters inside the shock absorber body.

Riding the motorcycle

Running-in recommendations

Maximum rpm

Rotation speed for running-in period and during standard use (rpm):

- 1) up to 1000 km;
- 2) from 1000 to 2500 km.

Up to 1000 km

During the first 1000 km, keep an eye on the rev counter. It should never exceed: $5,500 \div 6,000$ rpm.

During the first hours of riding, it is advisable to run the engine at varying load and rpm, though still within recommended limit.

To this end, roads with plenty of bends and even slightly hilly areas are ideal for a most efficient running-in of engine, brakes and suspensions.

For the first 100 km, use the brakes gently. Do not brake violently or keep brake applied for too long. This will enable a correct break-in of the friction material on the brake pads against the brake discs.

For all mechanical parts of the motorcycle to adapt to one another and above all not to adversely affect the life of basic engine parts, it is advisable to avoid harsh accelerations and not to run the engine at high rpm for too long, especially uphill.

Furthermore, the drive chain should be inspected frequently. Lubricate as required.

From 1000 to 2500 km

From 1000 to 2500 km you can squeeze some more power out of your engine. However, never exceed 7,000 rpm.

Important

During the whole running-in period, the maintenance and service rules recommended in the Warranty Booklet should be observed carefully. Failure to comply with these rules will release Ducati Motor Holding S.p.A. from any liability whatsoever for resulting engine damage or shorter engine life.

Strict observance of running-in recommendations will ensure longer engine life and reduce the likelihood of overhauls and tune-ups.

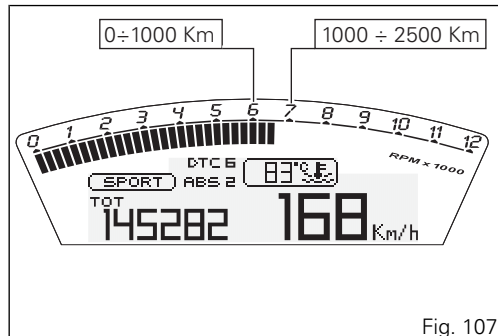

Fig. 107

Pre-ride checks



Warning

Failure to carry out these checks before riding, may lead to motorcycle damage and injury to rider and passenger.

Before riding, perform a thorough check-up on your bike as follows:

- FUEL LEVEL IN THE TANK
Check the fuel level in the tank. Fill tank if needed (page 168).
- ENGINE OIL LEVEL
Check the oil level in the sump through the sight glass. Top up if needed (page 191).
- BRAKE FLUID
Check fluid level in the relevant reservoirs (page 171).
- COOLANT
Check coolant level in the expansion reservoir. Top up if needed (page 170).
- TYRE CONDITION
Check tyre pressure and condition (page 189).

- CONTROLS
Work the brake, clutch, throttle and gear change controls (levers, pedals and twistgrip) and check for proper operation.
- LIGHTS AND INDICATORS
Make sure lights, indicators and horn work properly. Replace any burnt-out bulbs (page 181).
- KEY-OPERATED LOCKS
Ensure that fuel filler plug (page 147) and seat (page 148) are locked.
- SIDE STAND
Make sure that side stand operates smoothly and is in the correct position (page 151).

ABS light

After Key-On, the ABS light stays on.

When the vehicle speed exceeds 5 km/h, the warning light switches off to indicate the correct operation of the ABS system.



Warning

In case of malfunction, do not ride the motorcycle and contact a Ducati Dealer or authorised Service Centre.

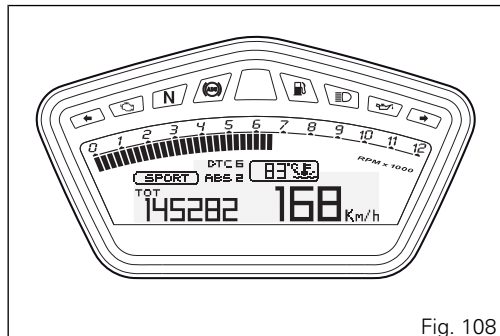

Fig. 108

ABS device

Check that the front (1) and rear (2) phonic wheels are clean.

Warning

Clogged reading slots would compromise system proper operation. It is recommended to disable ABS system in case of muddy road surface because under this condition the system might be subject to sudden failure.

Warning

Prolonged rearing could deactivate the ABS system.

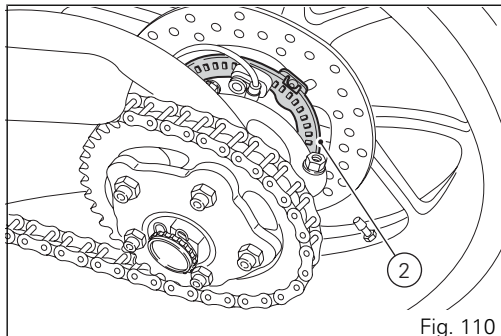
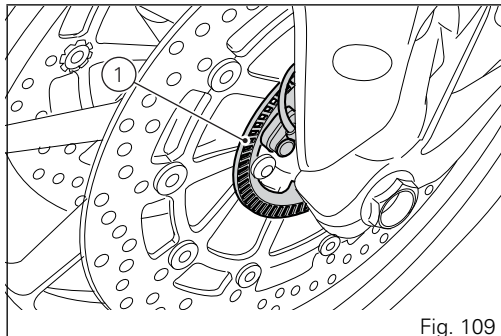

Starting the motorcycle

Warning

Before starting the engine, familiarise yourself with the controls that you will use when riding.

Warning

Never start or run the engine indoors. Exhaust gases are poisonous and may lead to loss of consciousness or even death within a short time.

Move the ignition switch to (1, Fig. 111). Make sure that both the green light N and the red light  on the instrument panel are on.

Important

The oil pressure light should go out a few seconds after the engine start.

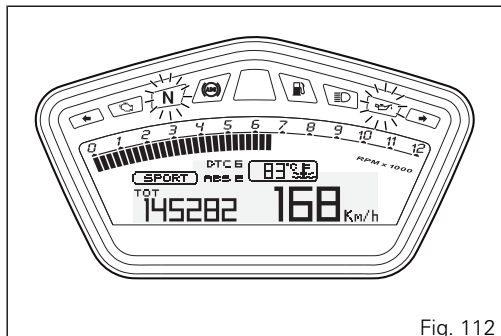
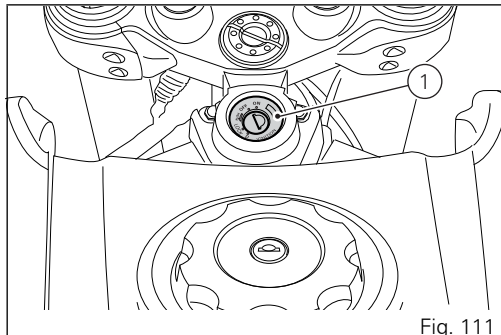



Warning

The side stand must be fully up (in horizontal position) as its safety sensor prevents engine start when down.



Note

It is possible to start the engine with side stand down and the gearbox in neutral. When starting the bike with a gear engaged, pull the clutch lever (in this case the side stand must be up).

Check that the stop switch (2Fig. 113), is positioned to  (RUN), then press the starter button (3Fig. 113).

Allow the engine to start on its own, without turning the throttle twistgrip.

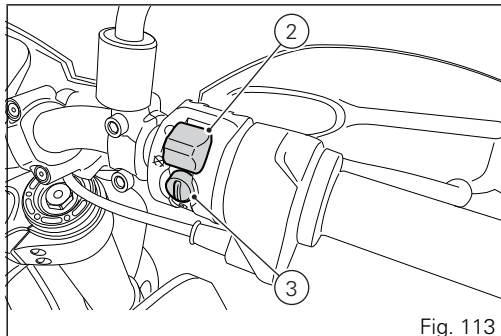

Fig. 113



Note

If the battery is flat, the system automatically disables operation of the starter motor.



Important

Do not rev up the engine when it is cold. Allow some time for the oil to warm up and reach all points that need lubricating.

Moving off

- 1) Disengage the clutch by squeezing the clutch lever.
- 2) Push down the gear change lever firmly with the tip of your foot to engage first gear.
- 3) Raise the engine revs by turning the throttle twistgrip while gradually releasing the clutch lever. The motorcycle will start moving off.
- 4) Release the clutch lever completely and accelerate.
- 5) To shift up, close the throttle to slow down engine, disengage the clutch, lift the gear change lever and let go of clutch lever.

To shift down, proceed as follows: release the twistgrip, pull the clutch lever, shortly speed up to help gears synchronise, shift down (engage next lower gear) and release the clutch.

The controls should be used correctly and timely: when riding uphill do not hesitate to shift down as soon as the motorcycle tends to slow down, so you will avoid stressing the engine and the motorcycle abnormally.



Warning

Avoid harsh accelerations, as this may lead to misfiring and transmission snatching. The clutch lever should not be held in longer than necessary after a gear is engaged, otherwise friction parts may overheat and wear out.



Warning

Prolonged rearing could deactivate the ABS system.

Braking

Slow down in time, shift down to engine-brake first and then brake applying both brakes. Pull in the clutch lever before the motorcycle comes to a stop to prevent the engine stalling.

ABS system

Using the brakes correctly under adverse conditions is the hardest – and yet the most critical - skill to master for a rider. Braking is one of the most difficult and dangerous moments when riding a two wheeled vehicle: the possibility of falling or having an accident during this difficult moment is statistically higher than any other moment. A locked front wheel leads to loss of traction and stability, resulting in loss of control.

The Anti-Lock Brake System (ABS) has been developed to enable riders to use the vehicles braking force to the fullest possible amount in emergency braking or under poor pavement or adverse weather conditions.

ABS uses hydraulics and electronics to limit pressure in the brake circuit when a special sensor mounted to the wheel signals the electronic control unit that the wheel is about to lock up.

This avoids wheel lockup and preserves traction.

Pressure is raised back up immediately and the

control unit keeps controlling the brake until the risk of a lockup disappears.

Normally, the rider will perceive ABS operation as a harder feel or a pulsation of the brake lever and pedal. The front and rear brakes use separate control systems, meaning that they operate independently. Likewise, the ABS is not an integral braking system and does not control both the front and rear brake at the same time.

If desired, the system can be disabled from the instrument panel, using the "ABS set-up" function (see page 72).



Warning

With the ABS system deactivated, the vehicle maintains the characteristics of the standard braking system, therefore the use of only one of the brakes reduces the motorcycle's braking efficiency. Never use the brake controls harshly or suddenly as you may lock the wheels and lose control of the motorcycle. When riding in the rain or on slippery surfaces, braking capacity is significantly reduced. Always use the brakes very gently and carefully when riding under these conditions. Any sudden manoeuvres may lead to loss of control. When tackling long, high-gradient downhill road tracts, shift down gears to use engine braking. Apply one brake at a time and use brakes sparingly. Keeping the brakes applied all the time would cause the friction material to overheat and reduce braking power dangerously. Tyre inflation pressures below the specified value will reduce braking efficiency, and compromise steering precision and roadholding on bends.

Stopping the motorcycle

Reduce speed, shift down and release the throttle twistgrip.

Shift down to engage first gear and then neutral.

Apply the brakes and bring the motorcycle to a complete stop.

To switch the engine off, simply turn the key to (2).

Important

Never leave the key in the ON position (1) when engine is stopped, or this will damage the electric components.

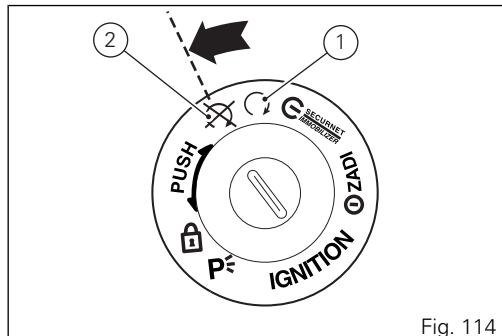

Fig. 114

Parking

Park the stopped motorcycle on the side stand. To prevent theft, turn the handlebar fully left and turn the ignition key to (3). If you park in a garage or other indoor area, make sure that there is proper ventilation and that the motorcycle is not near a source of heat. You may leave the parking lights on by turning the key to (4).

Important

Do not leave the key turned to position (4) for long periods or the battery will run down. Never leave the ignition key in the switch when you are leaving your bike unattended.

Warning

The exhaust system might be hot, even after engine is switched off; pay particular attention not to touch exhaust system with any body part and do not park the vehicle next to inflammable material (wood, leaves etc.).

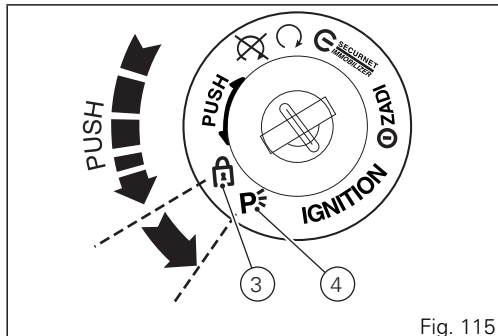

Fig. 115

Warning

Using padlocks or other locks designed to prevent motorcycle motion, such as brake disc locks, rear sprocket locks, and so on is dangerous and may impair motorcycle operation and affect the safety of rider and passenger.

Refuelling

Never overfill the tank when refuelling. Fuel should never be touching the rim of filler recess (1)

Warning

Use fuel with low lead content and an original octane number of at least 95.

Warning

The vehicle is only compatible with fuel having a maximum content of ethanol of 10% (E10). Using fuel with ethanol content over 10% is forbidden. Using it could result in severe damage of the engine and motorcycle components. Using fuel with ethanol content over 10% will make the warranty null and void.

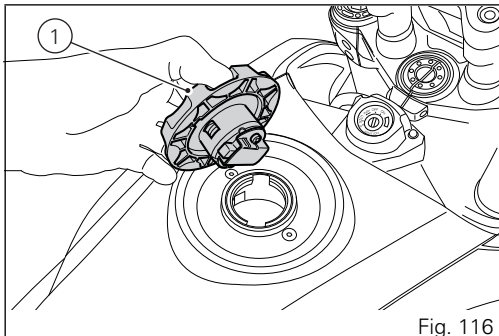

Fig. 116

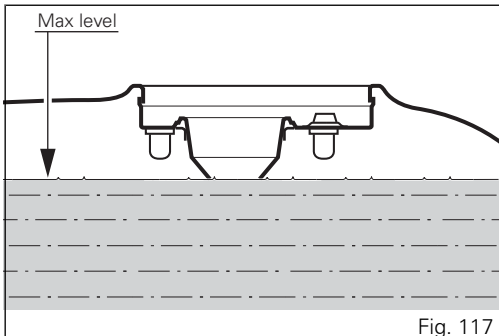

Fig. 117

Tool kit and accessories

Tool kit (2) and helmet anti-theft cable are located under the seat (1).

The tool kit includes:

- fuse pliers;
- 8/10 double-ended wrench;
- screwdriver;
- screwdriver handle;
- 14x16 mm box wrench;
- 6 mm rod;
- 3 mm Allen wrench;
- 5 mm Allen wrench;
- 6 mm Allen wrench.

To access the compartment remove the seat page 148.

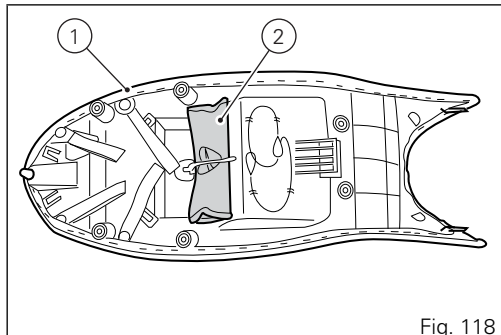

Fig. 118

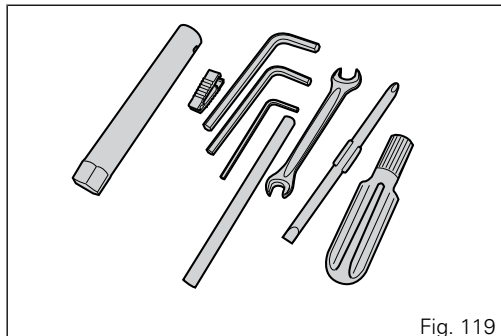
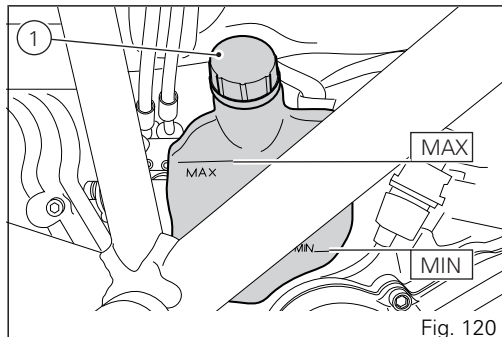

Fig. 119

Main maintenance operations

Check and top up the coolant level

Check the coolant level in the expansion reservoir on the right-hand side of the headstock. Steer the handlebar completely to the left and check that the level is between the MIN and MAX marks on the side of the expansion reservoir. Top up if the level is below the MIN mark. Unscrew the filler plug (1) and add ENI Agip Permanent Spezial antifreeze, which is not to be diluted, up to MAX level. Refit the filler plug (1). This type of mixture ensures the best operating conditions (the coolant starts to freeze at $-20\text{ }^{\circ}\text{C}/-4\text{ }^{\circ}\text{F}$).



Cooling circuit capacity: 2.3 cu. dm (litres).



Warning

Make sure the engine is cold before proceeding. A warm engine could provoke the ejection of coolant or hot vapour resulting in serious burns.

Checking brake and clutch fluid level

The level must not go below the MIN mark shown on the respective reservoirs ((Fig. 121) shows the front brake fluid reservoir and (Fig. 122) shows the rear brake reservoir).

If level drops below the limit, air might get into the circuit and affect the operation of the system involved.

Brake and clutch fluid must be topped up and changed at the intervals specified in the scheduled maintenance table reported in the Warranty Booklet; please contact a Ducati Dealer or authorised Service Centre.

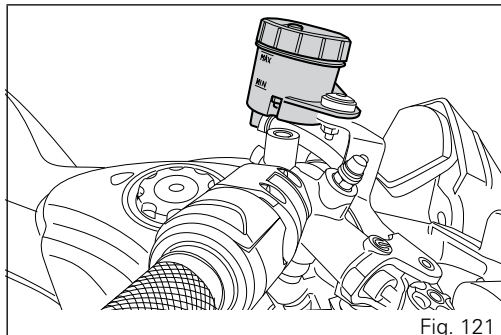

Important

It is recommended all brake and clutch lines be changed every four years.

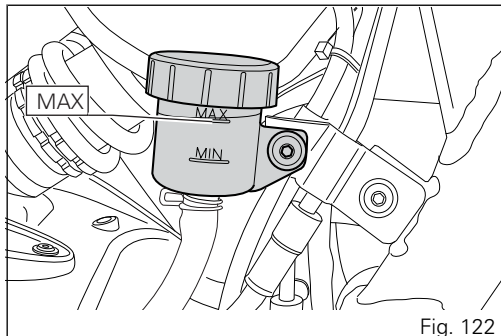

Brake system

If you find exceeding play on brake lever or pedal and brake pads are still in good condition, contact your Ducati Dealer or authorised Service Centre to have the system inspected and any air drained out of the circuit.



Warning

Brake fluid can damage paintwork and plastic parts, so avoid contact.

Hydraulic oil is corrosive; it may cause damage and lead to severe injuries. Never mix fluids of different qualities. Check seals for proper sealing.

Check brake pads for wear

Check brake pads wear through the inspection hole in the callipers.

Change both pads if friction material thickness of even just one pad is about 1 mm.

Warning

Friction material wear beyond this limit would lead to metal support contact with the brake disc thus compromising braking efficiency, disc integrity and rider safety.

Important

Have the brake pads replaced at a Ducati Dealer or authorised Service Centre.

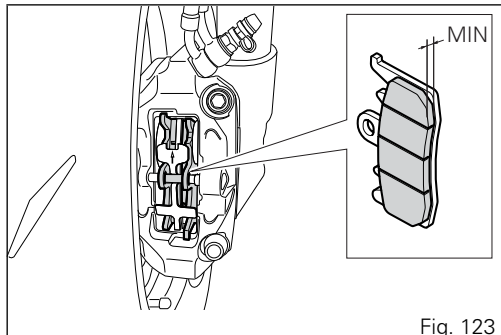

Fig. 123

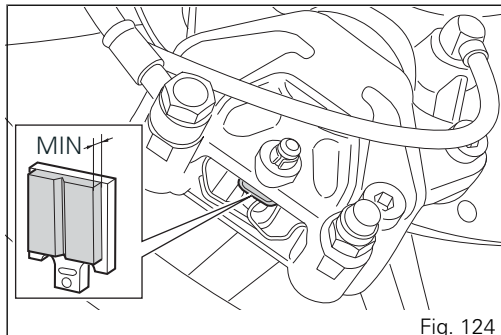

Fig. 124

Charge the battery

Warning

Have the battery removed at a Ducati Dealer or authorised Service Centre.

To gain access to battery, remove seat page 148. Loosen screws (1), remove the positive cable (2) and (ABS) positive cable (3) from the positive terminal and the negative cable (4) from the negative terminal, always starting from the negative one (-) and remove the battery from its compartment.

Warning

The battery gives off explosive gases; keep it away from any source of ignition such as sparks, flames and cigarettes. Charge the battery in a well-ventilated area.

Charge the battery in a ventilated room. Connect the battery charger leads to the battery terminals: the red one to the positive terminal (+), the black one to the negative terminal (-).

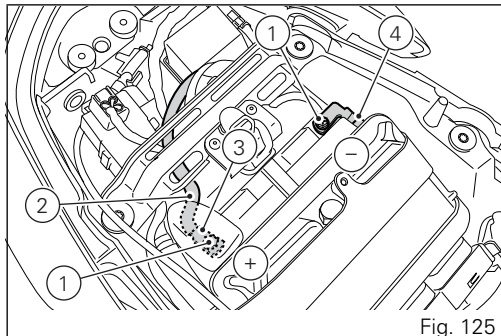

Important

Make sure the charger is off when you connect the battery to it, or you might get sparks at the battery terminals that could ignite the gases inside the cells. Always connect the red positive (+) terminal first.

Grease the screws (1).

Refit the battery, connect the positive cable (2) and ABS positive cable (3) to the positive terminal and the negative cable (4) to the negative terminal of the battery, always starting from the positive (+), and fit the screws (1).



Warning

Keep the battery out of the reach of children.

Charge the battery at 0.9 A for 5÷10 hours.

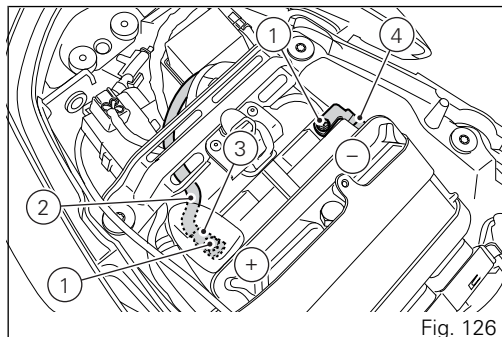

Fig. 126

Charging and maintenance of the battery during winter storage

Your motorcycle is equipped with a connector (1) under the seat to which you can connect a special battery charger (2) (Battery maintainer kit part no. 69924601A - various countries; Battery maintainer kit part no. 69924601AX - for Japan, China and Australia only) available from our sales network.



Note

The electric system of this motorcycle is designed so as to ensure there is a very low power drain when the motorcycle is off. Nevertheless, the battery features a certain self-discharge rate that is normal and depends on ambient conditions as well as on "non-use" time.

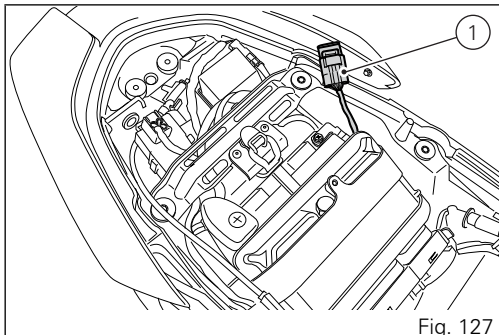

Fig. 127

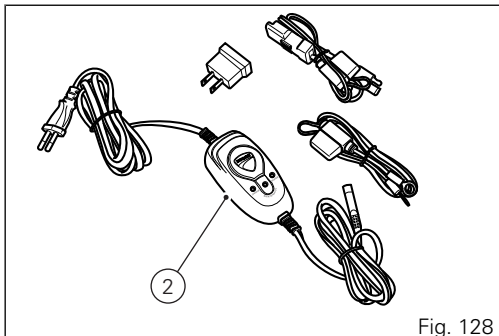

Fig. 128



Important

If battery is not kept at a minimum charge level by a suitable battery charge maintainer, sulphation may occur and this is an irreversible phenomenon causing decreasing battery performance.



Note

When the motorcycle is left used (approximately for more than 30 days). We recommend owners to use the Ducati battery charge maintainer (Battery maintainer kit part no. 69924601A - various countries; Battery maintainer kit part no. 69924601AX - for Japan, China and Australia only) since its electronics monitors the battery voltage and features a maximum charge current of 1.5 Ah. Connect the maintainer to the diagnostics socket located in the rear end of the bike.



Note

Using charge maintainers not approved by Ducati could damage the electric system; vehicle warranty does not cover the battery if damaged due to failure to comply with the above indications, since it is considered as wrong maintenance.

Check drive chain tension



Important

Have chain tension adjusted by a Ducati Dealer or authorised Service Centre.

Spin the rear wheel to find the position where chain is most taut. Set the motorcycle on the side stand. Press with a finger on the chain, at the point of measurement and then release it. Measure the distance (A) between the centre of chain link pins and the swingarm aluminium part. It must be: $A = 72 \div 74$ mm.



Important

If drive chain is too tight or slack, adjust tension so as to bring values back to the specified range.

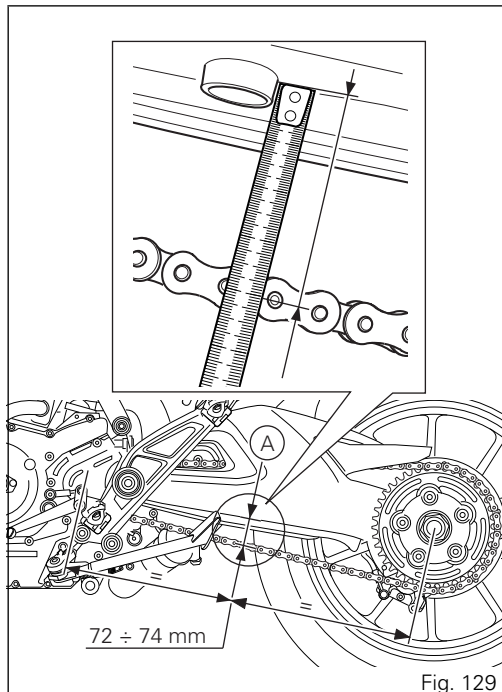

Warning
Correct tightening of swinging arm screws (1) is critical to rider and passenger safety.

Important
Improper chain tension will lead to early wear of transmission parts.

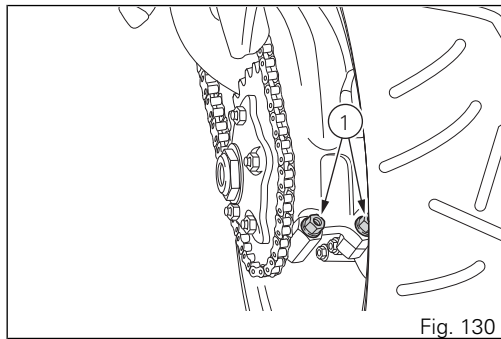

Chain lubrication

The chain fitted on your motorcycle has O-rings to protect its moving parts from dirt, and to hold the lubricant inside.

The seals might be irreparably damaged if the chain is cleaned using any solvent other than those specific for O-ring chains or washed using steam or water cleaners.

After cleaning, blow the chain dry or dry it using absorbent material and apply SHELL Advance Chain or Advance Teflon Chain on each link.



Important

Using non-specific lubricants may cause severe damage to the chain and the front and rear sprocket.

Replace the headlight bulbs



Important

Have the bulbs replaced at a Ducati Dealer or authorised Service Centre.



Warning

The headlight might fog up if the vehicle is used under the rain or after washing. Switch headlight on for a short time to dry up any condensate.

Before replacing a burnt-out bulb, make sure that the new one matches the voltage and wattage specifications in paragraph "Electric System" page 209. Always ensure that the new bulb you have installed operates properly before refitting any parts you have removed.

Loosen screws (1). Slightly raise the headlight support.

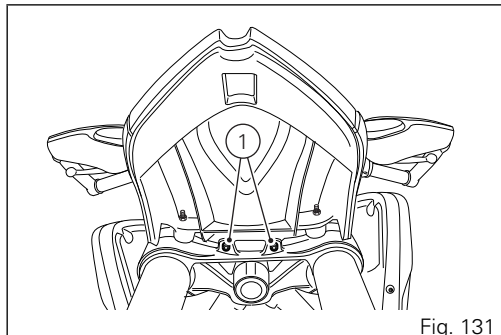

Fig. 131

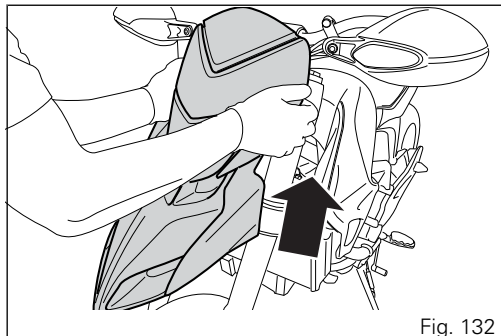
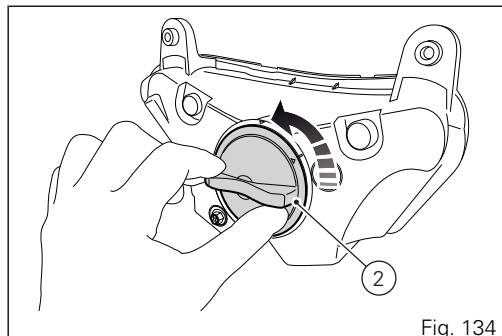
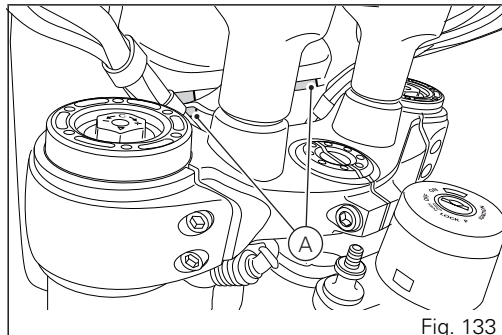

Fig. 132

Release the headlight support from rubber pads (A).
Ease off the headlight support towards the front until
releasing the twistgrip (2).
Unscrew the twistgrip (2) turning counter clockwise.



Disconnect connector (3).

Release the clip (4).

The bulb (5) has a bayonet base: press and twist counter clockwise to remove. Fit the spare bulb by pressing and turning clockwise until it clicks.



Note

Be careful to hold the new bulb at the base only. Never touch the transparent body with your fingers or it will blacken resulting in reduced bulb brilliancy.

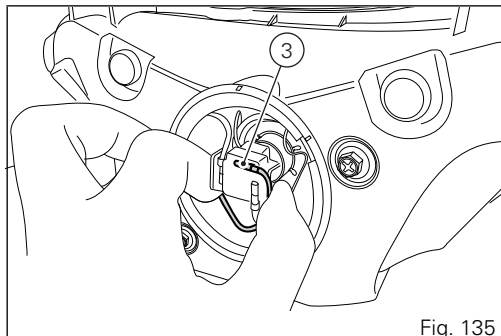

Fig. 135



Fig. 136

Replace the turn indicator bulbs

To change the front/rear turn indicator bulbs, loosen the screw (1) and remove the lens (2).

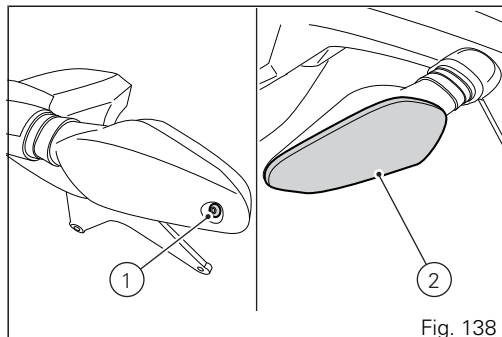
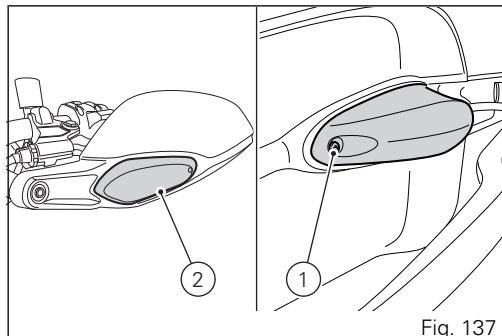

Number plate light

To access the bulb in the number plate light, open the number plate lens (1), pull the bulb (2) out of the holder and replace it.

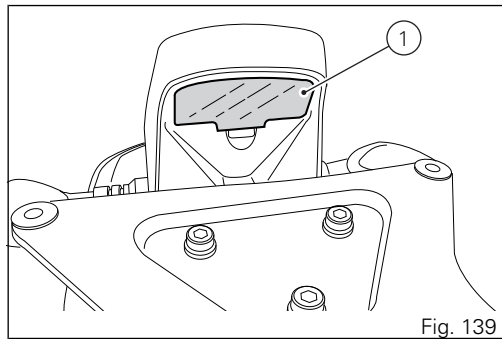

Fig. 139

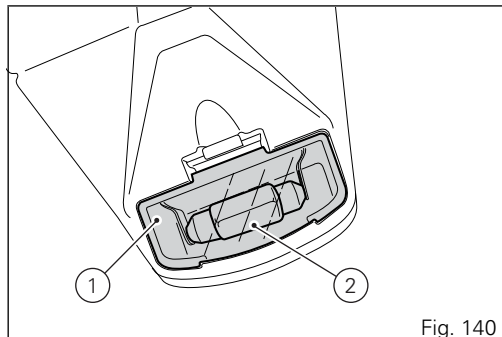

Fig. 140

Beam setting



Note

The headlight features a double beam adjustment, one for the right beam and one for the left beam

To check the headlight aim, place the motorcycle upright with the tyres inflated to the correct pressure and one person sitting astride the motorcycle. The motorcycle should be perfectly vertical, with its longitudinal axis at right angles to a wall or screen at a distance of 10 metres. then draw a horizontal line dictated by headlamp centre and a vertical one in line with the longitudinal axis of motorcycle. If possible, perform this check in dim light. Switch on the low beam and adjust the aiming of the left and right-hand beams. The height of the upper limit between the dark area and the lit area must not be more than nine tenths of the height from ground of headlight centre.

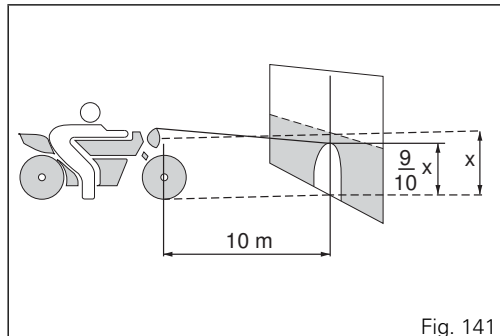

Fig. 141



Note

This is the procedure specified by Italian regulations for checking the maximum height of the light beam. Owners in other countries will adapt said procedure to the provisions in force in their countries.

Headlight adjustment

Turn the screw (1) to set beam height.

Turn the screw (2) to set beam height.



Important

Headlight adjusting screws have no limit stop.



Warning

The headlight might fog up if the vehicle is used under the rain or after washing. Switch headlight on for a short time to dry up any condensate.

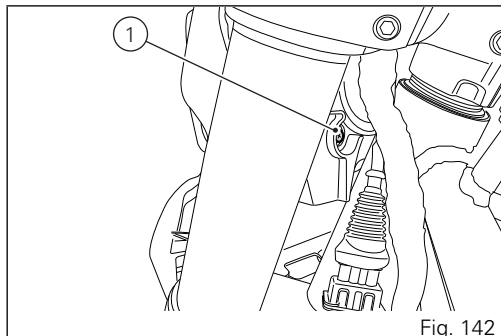

Fig. 142

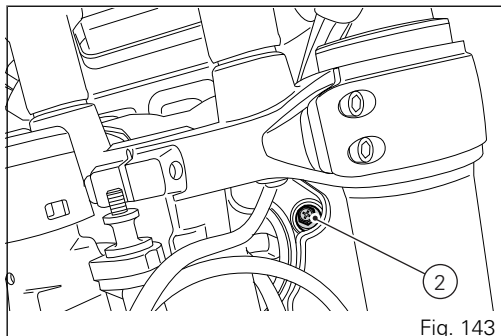
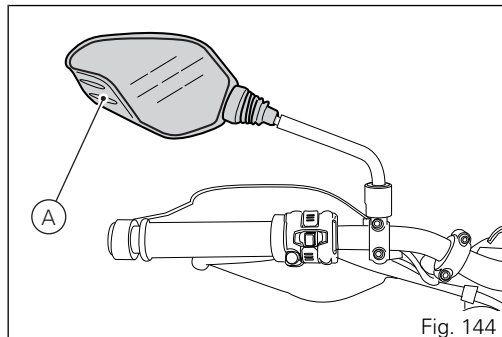

Fig. 143

Adjust rear-view mirrors

Manually adjust the rear-view mirror (A) until reaching the desired position.



Tubeless tyres

Front tyre pressure:

2.30 bar (rider only) - 2.50 bar (full load).

Rear tyre pressure:

2.10 bar (rider only) - 2.90 bar (full load).

As tyre pressure is affected by temperature and altitude variations, you are advised to check and adjust it whenever you are riding in areas where ample variations in temperature or altitude occur.

Important

Check and adjust the pressures with the tyres cold. To avoid front wheel rim distortion, when riding on bumpy roads, increase tyre pressure by 0.2 - 0.3 bar.

Tyre repair or change (Tubeless tyres)

In the event of a tiny puncture, tubeless tyres will take a long time to deflate, as they tend to keep air inside. If you find low pressure on one tyre, check the tyre for punctures.



Warning

Punctured tyres must be replaced. Replace tyres with recommended standard tyres only. Be sure to tighten the valve caps securely to avoid leaks when riding. Never use tube type tyres. Failure to heed this warning may lead to sudden tyre bursting and to serious danger to rider and passenger.

After replacing a tyre, the wheel must be balanced.



Warning

Do not remove or shift the wheel balancing weights.



Note

Have the tyres replaced at a Ducati Dealer or authorised Service Centre. Correct removal and installation of the wheels is essential. Some parts of the ABS (such as sensors and phonic wheels) are mounted to the wheels and require specific adjustment.

Minimum tread depth

Measure tread depth (S Fig. 145) at the point where tread is most worn down: it should not be less than 2 mm, and in any case not less than the legal limit.



Important

Visually inspect the tyres at regular intervals for detecting cracks and cuts, especially on the side walls, bulges or large spots that are indicative of internal damage. Replace them if badly damaged. Remove any stones or other foreign bodies caught in the tread.

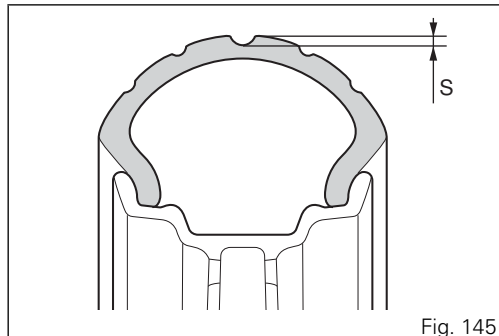

Fig. 145

Check engine oil level

Check the engine oil level through the sight glass (1) on the clutch cover. Oil level must be checked with the motorcycle perfectly upright and the engine cold. Oil level should be between the marks on the sight glass. If the level is low, top up with SHELL Advance 4T Ultra engine oil. Remove the oil filler cap (2) and top up until the oil reaches the required level. Refit the plug.

Important

Engine oil and oil filters must be changed by a Ducati Dealer or authorised Service Centre at the intervals specified in the scheduled maintenance table reported in the Warranty Booklet.

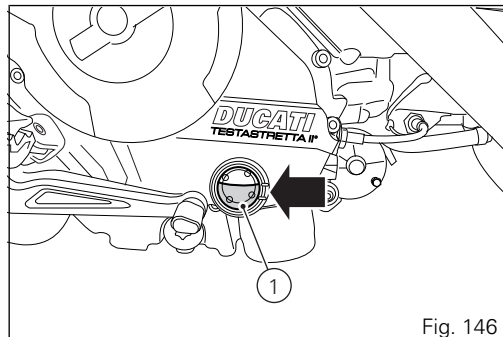
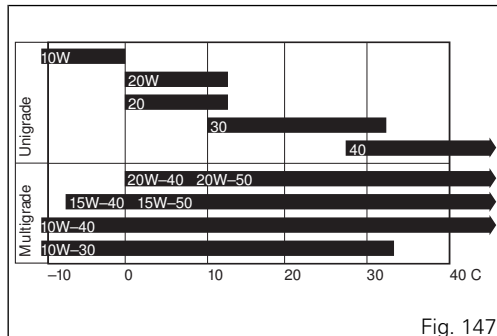

Fig. 146

Viscosity

SAE 15W-50

The other viscosity degrees indicated in the table can be used if the local average temperature is within the limits specified for that oil viscosity.



Clean and replace the spark plugs

Spark plugs are essential to smooth engine running and should be checked at regular intervals.

Have the spark plug replaced at a Ducati Dealer or authorised Service Centre.

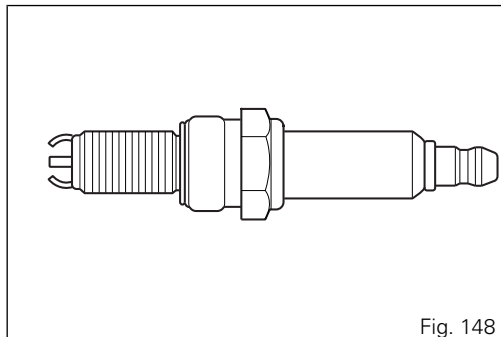

Clean the motorcycle

To preserve the finish of metal parts and paintwork, wash and clean your motorcycle at regular intervals, anyway according to the road conditions you ride in. Use specific products only. Prefer biodegradable products. Avoid aggressive detergents or solvents. Only use water and neutral soap to clean the Plexiglas and the seat.

Periodically manually clean all aluminium components. Use special detergents, suitable for aluminium parts FREE of abrasives or caustic soda.



Note

Do not use sponges with abrasive parts or steel wool: only use soft cloths.

However, the warranty does not apply to motorcycles whenever poor maintenance status is ascertained.



Important

Do not wash your motorcycle immediately after use, as marks can form due to evaporation of the water on hot surfaces.

Never clean the motorcycle using hot or high-pressure water jets.

Cleaning the motorcycle with a high pressure water jet may lead to seizure or serious faults in the front fork, wheel hub assembly, electric system, headlight (fogging), front fork seals, air inlets or exhaust silencers, with consequent loss of safety.

If parts of the engine are unusually dirty or greasy, use a degreasing agent, avoiding contact with transmission components (chain, front and rear sprockets, etc.).

Rinse with warm water and dry all surfaces with chamois leather.



Warning

Braking performance may be impaired immediately after washing the motorcycle. Never grease or lubricate the brake discs as this would cause loss of braking effectiveness. Clean the discs with an oil-free solvent.



Warning

The headlight might fog up due to washing, rain or moisture. Switch headlight on for a short time to help dry up any condensate.

Carefully clean the phonic wheels of the ABS so to ensure system efficiency. Do not use aggressive products so to avoid damaging the phonic wheels and the sensors.

Storing the motorcycle

If the motorcycle is to be left unriden over long periods, it is advisable to carry out the following operations before storing it away:

- clean the motorcycle;
- empty the fuel tank;
- pour a few drops of engine oil into the cylinders through the spark plug bores, then turn the engine over by hand a few times to form a protective film of oil on the inner walls of the cylinder;
- place the motorcycle on a service stand;
- disconnect and remove the battery.

Battery should be checked and charged (or replaced, as required) whenever the motorcycle has been left unriden for over a month.

Protect the motorcycle with a suitable canvas. This will protect paintwork and let condensate breathe out.

The canvas is available from Ducati Performance.

Important notes

The legislation in some countries (France, Germany, Great Britain, Switzerland, etc.) sets certain noise and pollution standards.

Periodically carry out the required checks and replace parts as necessary, using Ducati original spare parts, in compliance with the regulations in the country concerned.

Scheduled maintenance chart

Scheduled maintenance chart: operations to be performed by the Dealer

List of operations and type of intervention [set mileage (km/mi) or time interval *]	Km. x1000	1	15	30	45	60	Time (months)
	mi. x1000	0.6	9	18	27	36	
Reading of the error memory with DDS and check of Software version update on control units.		•	•	•	•	•	12
Check the presence of any technical updates and recall campaigns		•	•	•	•	•	12
Change engine oil and filter		•	•	•	•	•	12
Clean engine oil filter at intake		•					-
Check and/or adjust valve clearance				•		•	-
Replace the timing belts				•		•	60
Change spark plugs			•	•	•	•	60
Change the air filter				•		•	-
Check brake fluid level		•	•	•	•	•	12
Change brake fluid							36
Check pad wear and brake discs. Replace if necessary		•	•	•	•	•	12

List of operations and type of intervention [set mileage (km/mi) or time interval *]	Km. x1000	1	15	30	45	60	Time (months)
	mi. x1000	0.6	9	18	27	36	
Check tightening of the safety components (brake disc flange screws, brake calliper screws, front/rear wheel nuts, sprocket and final drive sprocket nuts)		●	●	●	●	●	12
Check and lubricate the rear wheel shaft				●		●	-
Check the drive chain tension and lubrication		●	●	●	●	●	12
Check final drive wear (chain, front and rear sprockets) and chain sliding shoes			●	●	●	●	12
Visual check of front fork and rear shock absorber seals		●	●	●	●	●	12
Change the front fork fluid					●		-
Check the freedom of movement and tightening of side and central stand (if installed)		●	●	●	●	●	12
Check rubbing points, clearance, freedom of movement and positioning of hoses and electric wiring in view		●	●	●	●	●	12
Check coolant level		●	●	●	●	●	12
Change coolant					●		48
Check electric fan operation		●	●	●	●	●	12
Check tyre pressure and wear		●	●	●	●	●	12
Check the battery charge level		●	●	●	●	●	12

List of operations and type of intervention [set mileage (km/mi) or time interval *]	Km. x1000	1	15	30	45	60	Time (months)
	mi. x1000	0.6	9	18	27	36	
Check idling		●	●	●	●	●	12
Check the operation of the safety electrical devices (side stand sensor, front and rear brake switches, engine stop switch, gear/neutral sensor)		●	●	●	●	●	12
Check the indicators and lighting		●	●	●	●	●	12
Reset Service indication through DDS		●	●	●	●	●	-
Road test of the motorcycle, testing the safety devices (ex. ABS and DTC)		●	●	●	●	●	12
Softly clean the motorcycle		●	●	●	●	●	12
Fill out that the service was performed in on-board documentation (Service Booklet)		●	●	●	●	●	12

Scheduled maintenance chart: operations to be performed by the customer

List of operations and type of intervention [set mileage (km/mi) or time interval *]	Km. x1000	1
	mi. x1000	0.6
	Months	6
Check engine oil level		●
Check brake fluid level		●
Check tyre pressure and wear		●
Check the drive chain tension and lubrication		●
Check brake pads. If necessary, contact your dealer to replace pads		●

Technical data

Weights

Overall weight (in running order with 90% of fuel - 93/93/EC): 194 kg.

Overall weight (without fluids and battery): 171 kg.

Maximum allowed weight (carrying full load): 406 kg.



Warning

Failure to observe weight limits could result in poor handling and impair the performance of your motorcycle, and you may lose control of the motorcycle.

Overall dimensions

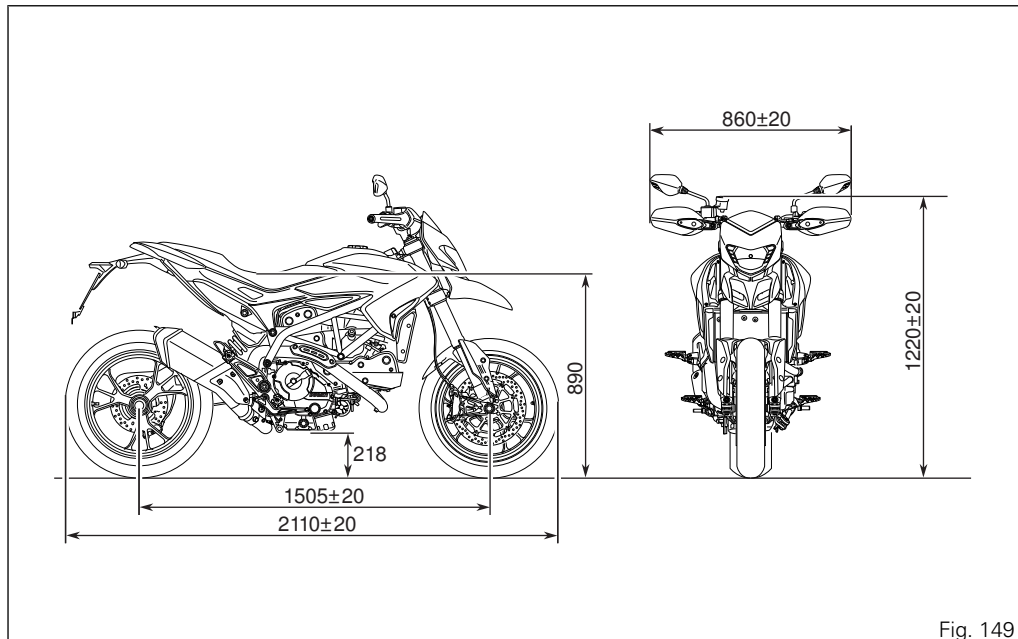

Fig. 149

Top-ups

TOP-UPS	TYPE	
Fuel tank, including a reserve of 4 cu. dm (litres)	Unleaded fuel with a minimum octane rating of RON 95.	16 cu. dm (litres)
Lubrication circuit	SHELL - Advance 4T Ultra	3.4 cu. dm (litres)
Front/rear brake and clutch circuits	SHELL Advance Brake DOT 4	-
Protectant for electric contacts	SHELL Advance Contact Cleaner	-
Front fork	SHELL Advance Fork 7.5 or Donax TA	230 cc



Important

Do not use any additives in fuel or lubricants. Using them could result in severe damage of the engine and motorcycle components.



Warning

The vehicle is only compatible with fuel having a maximum content of ethanol of 10% (E10). Using fuel with ethanol content over 10% is forbidden. Using it could result in severe damage of the engine and motorcycle components. Using fuel with ethanol content over 10% will make the warranty null and void.

Engine

Longitudinal 90° "L" twin cylinder, four-stroke.

Bore, mm:

88.

Stroke, mm:

67.5.

Total displacement, cu. cm:

821.1.

Compression ratio:

12.8±0.5:1

Max crankshaft power (95/1/EC), kW/HP:

81 kW/110 HP at 9,250 ^{rpm}

Max torque at crankshaft (95/1/EC):

9.1 kgm/89 Nm at 7,750 ^{rpm}

Maximum rpm:

10,500.



Important

Do not exceed the specified rpm limits in any running conditions.

Timing system

DESMODROMIC with four valves per cylinder, operated by eight rocker arms and two overhead camshafts. It is operated by the crankshaft through spur gears, belt rollers and toothed belts.

Desmodromic timing system

- 1) Opening (or upper) rocker
- 2) Opening rocker shim
- 3) Closing (or lower) rocker shim
- 4) Return spring for lower rocker
- 5) Closing (or lower) rocker
- 6) Camshaft
- 7) Valve.

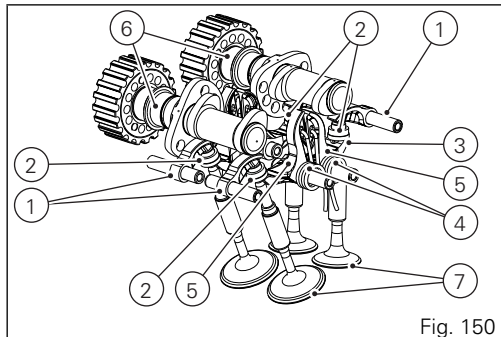

Performance data

Maximum speed in any gear should be reached only after a correct running-in period with the motorcycle properly serviced at the recommended intervals.



Important

Failure to follow these instructions will release Ducati Motor Holding S.p.A. from any liability for any engine damage or shortened engine life.

Spark plugs

Make:

NGK

Type:

MAR9A-J

Fuel system

MARELLI indirect electronic injection.

52 mm dia. round section throttle body with full Ride-by-Wire system.

Injectors per cylinder: 1

Firing points per injector: 4

Fuel specifications: 95-98 RON.



Warning

The vehicle is only compatible with fuel having a maximum content of ethanol of 10% (E10). Using fuel with ethanol content over 10% is forbidden. Using it could result in severe damage of the engine and motorcycle components. Using fuel with ethanol content over 10% will make the warranty null and void.

Brakes

Separate-action anti-lock brake system operated by hall-type sensors mounted to each wheel with phonic wheel detection: ABS can be disabled.

FRONT

Semi-floating drilled twin-disc.

Braking material: steel.

Carrier material: black steel.

Disc diameter: 320 mm.

Hydraulically operated by a control lever on handlebar right-hand side.

Brake calliper make: BREMBO.

Type: M4.3 pistons.

Friction material: TT 2182 FF.

Master cylinder type: PS 18/18.

REAR

With fixed drilled steel disc.

Disc diameter: 245 mm.

Hydraulically operated by a pedal on RH side.

Make: BREMBO

Type: P34e.

Friction material: FERIT I/D 450 FF.

Master cylinder type: PS 11.

Warning

Brake fluid can dissolve paintwork.

In the event of accidental contact with eyes or skin, wash the affected area with abundant running water.

Transmission

Multiplate wet clutch controlled mechanically, by the lever on left-hand side of the handlebar. Self-servo and slipper mechanism.

Drive is transmitted from engine to gearbox main shaft via spur gears.

Engine sprocket/clutch gearwheel ratio: 33/61

6-speed gearbox with constant mesh gears, gear change pedal on left side of motorcycle.

Gearbox output sprocket/rear chain sprocket ratio: 15/45

Total gear ratios:

1st gear 15/37

2nd gear 17/30

3rd gear 20/28

4th gear 22/26

5th gear 23/24

6th gear 24/23

Drive chain from gearbox to rear wheel:.

Make: DID

Type: 252 VAZ

Size: 5/8" x 1/16"

Links: 108

Important

The above gear ratios are the homologated ones and under no circumstances must they be modified.

However, if you wish to tune up your motorcycle for competitions or special tracks, Ducati Motor Holding S.p.A. will be pleased to provide information about the special ratios available. Contact a Ducati Dealer or Authorised Service Centre.



Warning

If the rear sprocket needs replacing, contact a Ducati Dealer or authorised Service Center.

Incorrect replacement of this component could seriously endanger rider and passenger safety and cause irreparable damage to the motorcycle.

Frame

Steel tube trellis frame.

Die-cast aluminum rear subframe.

Steering head angle: 25.5°.

Wheels

Front

3-spoke, light-alloy forged rims.

Size: MT3.50x17"

Rear

3-spoke, light-alloy forged rims.

Size: MT5.50x17"

Both wheels have removable axles.

Tyres

Front

Tubeless, radial tyre.

Size: 120/70-ZR17

Rear

Tubeless, radial tyre.

Size: 180/55-ZR17

Suspensions

Front

Pressurised upside-down fork in aluminium alloy with hard oxide coating, fully adjustable.

Stanchion diameter:

50 mm.

Wheel travel: 185 mm.

Rear

Progressive. The shock absorber is adjustable for compression and spring preload. At the bottom pivot point it is connected to a die-cast aluminium single-sided swingarm. The whole system gives the bike excellent stability.

Shock absorber stroke: 61.5 mm.

Rear wheel travel: 175 mm.

Exhaust system

Single stainless steel muffler.

Catalytic converter built into the silencer with two Lambda sensors on the exhaust pipes at the head output.

Available colours

Primer (2 K Black Primer) code 873.A002 (PALINAL);

Undercoat (Black Stealth - Black 94) code 929.R223
(PALINAL);

Undercoat (tricolore white) code 929.D398
(PALINAL);

Clear lacquer code 923M1598 (PALINAL);

Mercury Grey (Powder mercury grey) subframe code
79086 (INVER);

Red (Ducati Red) frame code 81784 (INVER);

Black rims.

Electrical system

Basic electric items are:

Headlight:

low/high beams: bulb H4 blue vision (12V – 60/55W);

parking light: no. 8 LEDs;

Electrical controls on handlebars.

Turn indicators:

front: bulb type GE 2641A 12VRY10W;

rear: bulb type GE 2641A 12VRY10W.

Horn.

Stop light switches.

Battery, 12V-10 Ah, dry.

GENERATOR 14V-490W.

ELECTRONIC VOLTAGE REGULATOR, protected with a 30 A fuse located close to the rear fuse box (C, Fig. 153).

Starter motor: 12V-0.7 kW.

Tail light:

parking light: 6 LEDs (0.4W -13.5V);

stop light: 6 LEDs (2.7W-13.5V).

Number plate light:

bulb type: C5W (12-5W).



Note

For bulb replacement instructions, please read "Replacing the high and low beam bulbs".

Fuses

There are thirteen fuses that protect the electric components located inside the front and rear fuse boxes, and one on the electric solenoid starter. There is a spare fuse in every box.

Refer to the table below to identify the circuits protected by the various fuses and their ratings.

The front fuse box (A, Fig. 151) is located on the LH side and can be accessed by removing the front LH side fairing. To expose the fuses, lift the box protective cover. Mounting position and ampere capacity are marked on box cover.

The rear fuse box (B, Fig. 152) is located under the seat, close to the ABS control unit. To gain access to rear fuse box, remove seat, refer to page 148. To expose the fuses, take off the box protective cover. Mounting position and ampere capacity are marked on box cover.

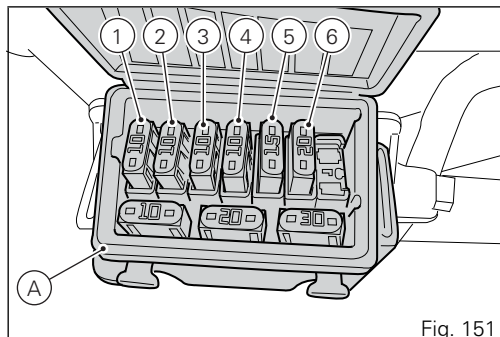

Fig. 151

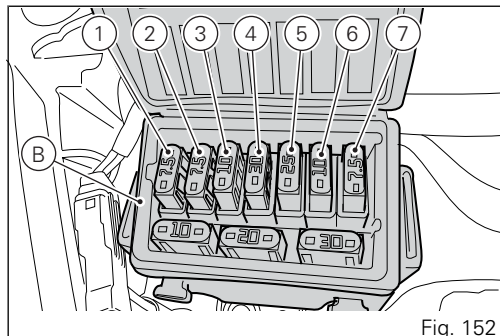

Fig. 152

Front fuse box key		
Pos	El. item	Rat.
1	Lights	10 A
2	Instrument panel	10 A
3	Key-1	15 A
4	Key-2	10 A
5	Key-7SM	15 A
6	Injection	20 A
7	-	-

Rear fuse box key		
7	ECU	7.5 A

Rear fuse box key		
Pos	El. item	Rat.
1	Key-sense	7.5 A
2	Diagnosis	7.5 A
3	Black Box System (BBS)	10 A
4	ABS 1	30 A
5	ABS 2	25 A
6	Alarm	10 A

The main fuse (C), is positioned close to the rear fuse box, on the solenoid starter (D). Remove the fuse cap (E) to reach it. A blown fuse is identified by the interrupted centre link (F).



Important

Switch the ignition key to OFF before replacing the fuse to avoid possible short-circuits.



Warning

Never use a fuse with a rating other than specified. Failure to observe this rule may damage the electric system or even cause fire.

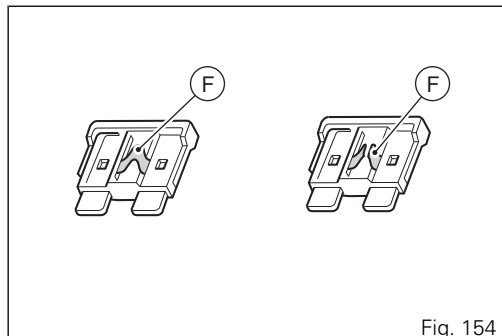
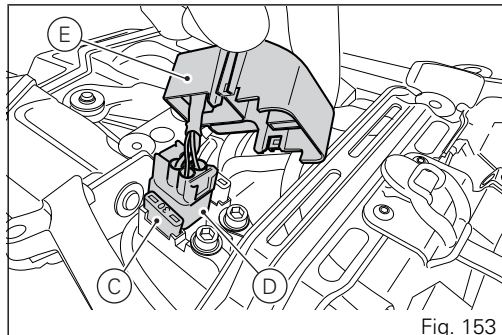

Injection /electric system diagram key

- 1) Right-hand switch
- 2) Ignition system (key-operated switch)
- 3) Main relay
- 4) Regulator
- 5) Generator
- 6) Navigator
- 7) Front fuse box
- 8) Starter motor
- 9) Fused solenoid
- 10) Battery
- 11) Wiring ground
- 12) Data Acquisition/Diagnosis
- 13) Rear fuse box
- 14) ABS control unit
- 15) ABS Diagnosis
- 16) Front speed sensor
- 17) Rear speed sensor
- 18) Right fan
- 19) Left fan
- 20) Rear light
- 21) Rear right turn indicator
- 22) Rear wiring loom
- 23) Rear left turn indicator
- 24) Exhaust valve starter motor
- 25) Vehicle control unit (BBS)
- 26) Antitheft alarm
- 27) Oil pressure switch
- 28) Gear sensor
- 29) Side stand switch
- 30) Clutch switch
- 31) Timing/rpm sensor
- 32) Vertical MAP sensor
- 33) Horizontal MAP sensor
- 34) Engine temperature
- 35) Vertical lambda sensor
- 36) Horizontal lambda sensor
- 37) Throttle twistgrip position sensor (APS)
- 38) Potentiometer motor / ride-by-wire (TPS/ETV) - horizontal
- 39) Potentiometer motor / ride-by-wire (TPS/ETV) - vertical
- 40) Horizontal coil
- 41) Vertical coil
- 42) Main horizontal injector
- 43) Main vertical injector
- 44) Secondary air actuator
- 45) Fuel pump
- 46) Fuel pump relay
- 47) Control unit - body connector
- 48) Control unit - engine connector

- 49) Left-hand switch
- 50) Front left turn indicator
- 51) Horn
- 52) Air temperature sensor
- 53) Heated grips
- 54) Instrument panel
- 55) Rear stop
- 56) Front stop
- 57) Front right turn indicator
- 58) Headlight
- 59) Serial line
- 60) Immobilizer

Wire colour coding

- B Blue
- W White
- V Violet
- Bk Black
- Y Yellow
- R Red
- Lb Light blue
- Gr Grey
- G Green
- Bn Brown
- O Orange

P Pink



Note

The electric system wiring diagram is at the end of this manual.

Routine maintenance record

Routine maintenance record

KM	NAME	MILEAGE	DATE
	DUCATI SERVICE		
1000			
15000			
30000			
45000			
60000			

Stampato 02/2013

Cod. 913.7.232.1A

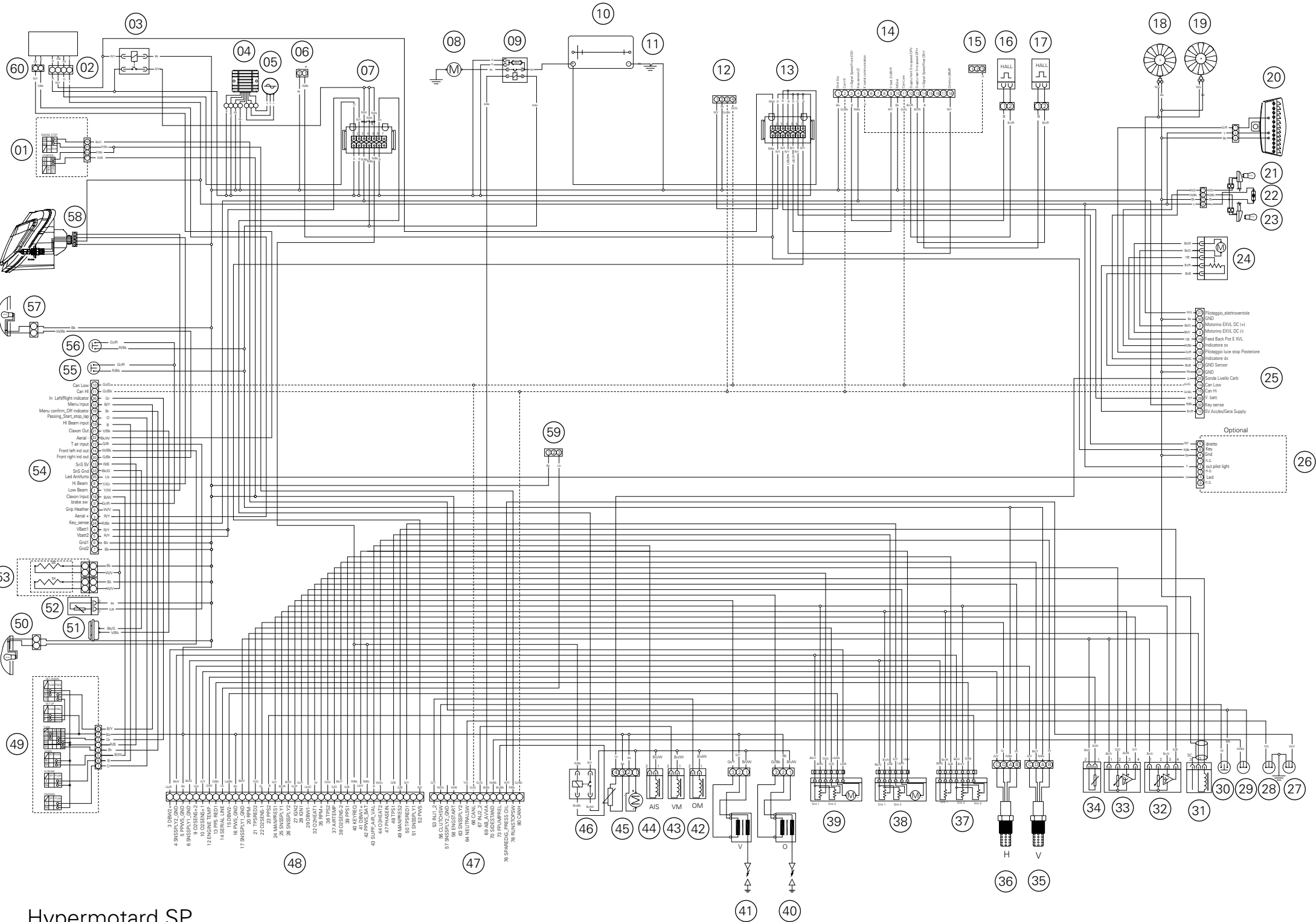

- 3. DRIVO
- 4. SNSPNTZ_GND
- 5. SNSPNTZ_GND
- 6. SNSPNTZ_GND
- 7. SNSPNTZ_GND
- 8. OSSENS-+
- 9. OSSENS-+
- 10. OSSENS-+
- 11. OSSENS-+
- 12. OSSENS-+
- 13. OSSENS-+
- 14. OSSENS-+
- 15. OSSENS-+
- 16. OSSENS-+
- 17. OSSENS-+
- 18. OSSENS-+
- 19. OSSENS-+
- 20. OSSENS-+
- 21. OSSENS-+
- 22. OSSENS-+
- 23. OSSENS-+
- 24. OSSENS-+
- 25. OSSENS-+
- 26. OSSENS-+
- 27. OSSENS-+
- 28. OSSENS-+
- 29. OSSENS-+
- 30. OSSENS-+
- 31. OSSENS-+
- 32. OSSENS-+
- 33. OSSENS-+
- 34. OSSENS-+
- 35. OSSENS-+
- 36. OSSENS-+
- 37. OSSENS-+
- 38. OSSENS-+
- 39. OSSENS-+
- 40. OSSENS-+
- 41. OSSENS-+
- 42. OSSENS-+
- 43. OSSENS-+
- 44. OSSENS-+
- 45. OSSENS-+
- 46. OSSENS-+
- 47. OSSENS-+
- 48. OSSENS-+
- 49. OSSENS-+
- 50. OSSENS-+
- 51. OSSENS-+
- 52. OSSENS-+
- 53. OSSENS-+
- 54. OSSENS-+
- 55. OSSENS-+
- 56. OSSENS-+
- 57. OSSENS-+
- 58. OSSENS-+
- 59. OSSENS-+

- 1. Hologgio_elettroventole
- 2. IND
- 3. Motore EXVL DC (+)
- 4. Motore EXVL DC (-)
- 5. Led Back Pot E XVL
- 6. Indicatore dx
- 7. Hologgio luce stop Posteriore
- 8. Indicatore dx
- 9. IND
- 10. Sonda Livello Carb
- 11. Led Low
- 12. Key sensor
- 13. batt
- 14. V Access/Gere Supply

- Optional
- 1. Hetro
 - 2. Key
 - 3. Ind
 - 4. Led pilot light
 - 5. Led
 - 6. C.

cod. 913.7232.1A

Ducati Motor Holding spa
www.ducati.com

Via Cavalieri Ducati, 3
40132 Bologna, Italy
Ph. +39 051 6413111
Fax +39 051 406580

A Sole Shareholder Company
An Audi Group Company