

DUCATI MONSTER S2R

E

We would like to welcome you among Ducati enthusiasts, and congratulate you for choosing a Ducati motorcycle. We are sure that you will use your Ducati motorcycle for longer journeys as well as short daily trips, but however you use your motorcycle, Ducati Motor Holding s.p.a wishes you an enjoyable ride.

We are continuously working to improve our Technical Assistance service. For this reason, we recommend that you follow strictly the instructions in this manual, especially those regarding the running-in period. In this way, you can be sure your Ducati motorcycle will continue to be a pleasure to ride.

For repairs or advice, please contact one of our authorized service centres.

There is also an information service available to all Ducati owners and enthusiasts for any advice and suggestions you might need.

Enjoy the ride!



Notes

Ducati Motor Holding S.p.A. cannot accept any liability for errors that may have occurred in the preparation of this manual. All information in the manual was valid at the time of going to print. Ducati Motor Holding S.p.A. reserves the right to make any modifications required due to the ongoing development of their products.

For safety and reliability, to avoid invalidating the warranty and to maintain the value of your motorcycle, use only original Ducati spare parts.



Warning

This manual is an integral part of the motorcycle and, if ownership is transferred to a third party, must always be passed to the new owner.

Table of contents

E General indications 6

- Warranty 6
- Symbols 6
- Useful road safety information 7
- Riding with a full load 8
- Identification data 9

Controls 10

- Position of the motorcycle controls 10
- Instrument panel 11
- LCD functions 13
- The immobilizer system 16
- Keys 16
- Code card 17
- Procedure to override the immobilizer using the throttle twistgrip 18
- Duplicate keys 19
- Ignition switch and steering lock 20
- Left-hand handlebar switch 21
- Clutch lever 22
- Cold start lever 23
- Right-hand handlebar switch 24
- Throttle twistgrip 25

- Front brake lever 25
- Rear brake pedal 26
- Gearchange pedal 26
- Adjusting the position of the gearchange pedal 27
- Adjusting the position of the rear brake pedal 28

Main components and devices 29

- Position on motorcycle 29
- Fuel tank filler cap 30
- Seat lock and helmet holder 31
- Sidestand 32
- Rear shock absorber adjusters 33
- Adjusting the rear ride height 35

Riding the motorcycle 37

- Running-in recommendations 37
- Pre-ride checks 38
- Starting the engine 39
- Moving off 41
- Braking 42
- Stopping the motorcycle 43
- Refuelling 43
- Parking 44
- Toolkit and accessories 45

Main Maintenance Operations 46

- Removing the fairing panels (S2R) 46
- Lifting the fuel tank 47
- Changing the air filter 48
- Checking the brake and clutch fluid level 49

Checking the brake pads for wear 50
Lubricating cables and joints 51
Adjusting the throttle cable 52
Charging the battery 53
Tensioning the drive chain 54
Lubrication of the drive chain 55
Replacing bulbs 56
Headlight aim 60
Tyres 61
Checking the engine oil level 63
Cleaning and renewing the spark plugs 64
General cleaning 65
Storing the motorcycle 66
Important notes 66

Maintenance 67

Programmed maintenance plan operations to be carried out by the dealer 67
Programmed maintenance plan: operations to be carried out by the dealer 70

Technical data 71

Overall dimensions (mm) 71
Weights 71
Fuel, lubricants and other fluids 72
Engine 73
Timing system 73
Performance data 74
Spark plugs 74
Fuel system 74
Brakes 75

Transmission 76
Frame 77
Wheels 77
Tyres 77
Suspension 77
Exhaust system 78
Available colours 78
Electrical system 78

Periodic maintenance record 84

For United States of America Version Only 85

Reporting of safety defects 85
Safety warnings 85
Noise emission warranty 85
Noise and exhaust emission control system information 85
Tampering warning 86
Riding safety 87
Protective apparel 88
Vehicle identification number (VIN) 88
Label location 89
California evaporation emission system 91
Ducati limited warranty on emission control system 91

Routine maintenance record 94

General indications

E

Warranty

In your own best interest, and to maintain reliability and the terms of warranty, you are strongly advised to contact a Ducati Dealer or Authorized Service Centre for any operations that require professional expertise.

Our highly qualified staff have access to the specialised tools required to perform any servicing job to the highest professional standards, using only Ducati original spare parts as the best guarantee for perfect interchangeability, smooth running and long service life.

All Ducati motorcycles come with a "Warranty Booklet". However, the warranty does not apply to motorcycles used in competitions. If any motorcycle part is tampered with, modified, or replaced with parts other than original Ducati spare parts during the warranty period, the warranty will be automatically invalidated.

Symbols

Ducati Motor Holding S.p.A. advises you to read this manual carefully in order to familiarise yourself with your motorcycle. If in doubt, please contact a Ducati Dealer or Authorized Service Centre. The information in this manual will help ensure that your riding experience is trouble-free and enjoyable, and it will help you obtain top performance from your motorcycle a long time. This booklet uses a set of symbols with special meanings:



Warning

Failure to comply with these instructions may put you at risk, and lead to severe injury or even death.



Important

There is the possibility of causing damage to the motorcycle and/or its components.



Notes

Additional information about the current operation.

References to the **right** or **left** side of the motorcycle assume you are sitting on the seat, facing forward.

Useful road safety information



Warning

Read this section before riding your motorcycle.

Many accidents are the result of the inexperience of the rider. Always make sure you have your licence with you; you need a valid licence that entitles you to ride a motorcycle.

Do not lend your motorcycle to persons that are inexperienced or do not hold a valid licence.

Riders and passengers must **always** wear appropriate clothing and a safety helmet.

Do not wear loose clothes or accessories that could become tangled in the controls or limit your field of vision.

Never start or run the engine in enclosed space.

Exhaust gases are poisonous and may lead to loss of consciousness or even death within a short time.

The rider should keep his/her feet on the footrests when the motorcycle is in motion.

Always hold the handlebars firmly with both hands so you will be ready for sudden changes in direction or in the road surface. The pillion passenger should **always** hold on to the grabhandles under the seat with both hands.

Obey the legal requirements and observe national and local regulations.

Always respect speed limits where these are indicated and **always** adapt your speed to suit the current visibility, road and traffic conditions.

Always signal your intention to turn or change lane in good time, using the appropriate turn signal indicators.

Be sure you are clearly visible and avoid riding within the blind spot of the vehicle in front of you.

Be very careful at road junctions, or when riding in areas near exits from private land or car parks, or on the slip roads to motorways.

Always turn off the engine when refuelling. Be extremely careful not to spill fuel on the engine or on the exhaust pipe when refuelling.

Do not smoke when refuelling.

While refuelling, it is possible to inhale noxious fuel vapours. Should any fuel drops be spilled on your skin or clothing, immediately wash with soap and water and change your clothing.

Always remove the key if leaving your motorcycle unattended. The engine, exhaust pipes and silencers stay hot for a long time.



Warning

The exhaust system might still be hot even if the engine is switched off; take special care not to touch the exhaust system with any part of your body and do not park the motorcycle next to inflammable material (wood, leaves etc.).

Park your motorcycle where no one is likely to knock against it, and use the side stand.

Never park on uneven or soft ground, or your motorcycle may fall over.

Riding with a full load

Your motorcycle is designed for travelling over long distances with a full load in complete safety.

Even weight distribution is critical for maintaining safety standards, and to avoid getting into difficulties when making sudden manoeuvres or riding on bumpy roads.

E

Information on load capacity

The total weight of the motorcycle in running order with rider, luggage and additional accessories should not exceed 390 kg.

Arrange your luggage or heavy accessories in the lowest possible position and close to the centre of the motorcycle.

Secure the luggage firmly to the motorcycle structure.

Luggage incorrectly secured may cause the motorcycle to become unstable.

Never fix bulky or heavy objects to the top yoke or front mudguard, as this would cause dangerous instability.

Do not insert objects into gaps in the frame, where they could interfere with moving parts.

Check that the tyres are inflated to the pressure indicated on page 61 and that they are in good condition.

Identification data

All Ducati motorcycles have two identification numbers, one for the frame (fig. 1) and one for the engine (fig. 2).

Frame number

Engine number



Notes

These numbers indicate the motorcycle model, and should be quoted when ordering spare parts.

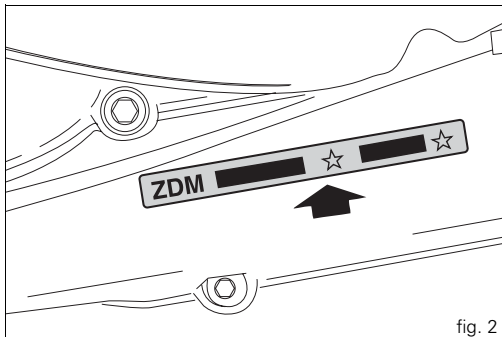
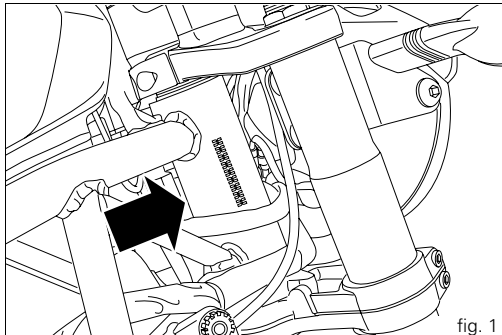

Controls

E



Warning

This section shows the position and function of the controls used to drive the motorcycle. Be sure to read this information carefully before you use the controls.

Position of the motorcycle controls (fig. 3)

- 1) Instrument panel.
- 2) Key-operated ignition switch and steering lock.
- 3) Left-hand handlebar switch.
- 4) Clutch lever.
- 5) Cold start lever.
- 6) Right-hand handlebar switch.
- 7) Throttle twistgrip.
- 8) Front brake lever.
- 9) Gearchange pedal.
- 10) Rear brake pedal.

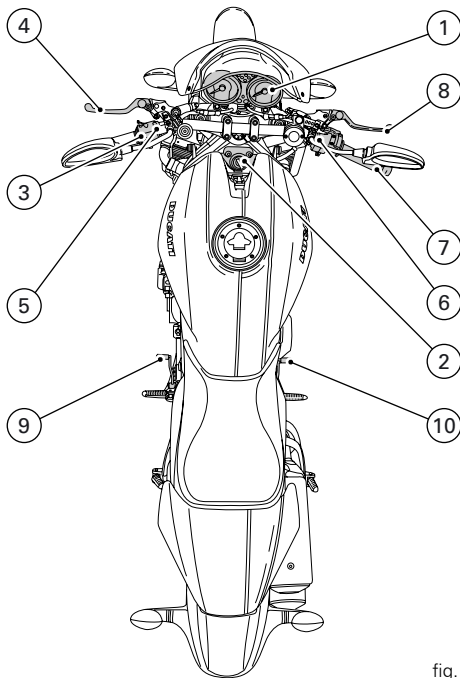





fig. 3

Instrument panel (fig. 4.1 and fig. 4.2)

- 1) **High beam warning light**  (blue).
Illuminates when the high beam headlight is on.
- 2) **Turn signal warning light**  (green).
Flashes when a turn signal is on.
- 3) **Low fuel warning light**  (yellow).
Illuminates when there are approximately 3 litres of fuel left in the tank.
- 4) **Neutral light N** (green).
Illuminates when the gearbox is in neutral.
- 5) **Engine oil pressure warning light**  (red).
Illuminates when engine oil pressure is too low. This light comes on when the ignition is switched to **ON** and should go out a few seconds after the engine starts. It may come on briefly if the engine is very hot, but should go out again as engine speed increases.

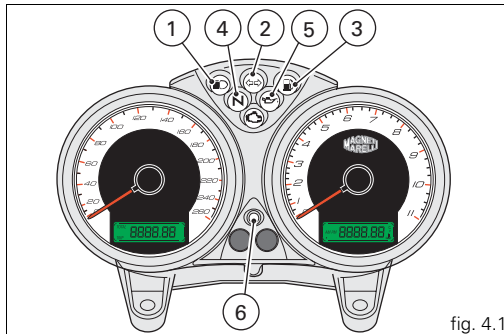

fig. 4.1

Important

Do not use the motorcycle if this light stays on, otherwise the engine could be damaged.

6) **Amber warning light**

Comes on and flashes when the motorcycle is parked (immobilizer on); also used for immobilizer diagnostics.

Notes

When the immobilizer is activated, the light flashes for 24 hours after which it goes off, but the immobilizer remains active.

7) EOBD light  (yellow amber).

Comes on when the engine is locked. Switches off after a few seconds (normally 1.8 - 2 sec.).

8) Speedometer (km/h).

Indicates road speed.

a) LCD (1):

- **Odometer** (km).

Shows total distance travelled.

- **Trip meter** (km).

Shows distance travelled since last reset.

- **Fuel reserve trip counter.**

When the fuel level warning light is on, displays the number of kilometres travelled in reserve.

9) Tachometer (rpm).

Indicates engine revs per minute.

b) LCD (2):

- **Clock**

- **Oil temperature**

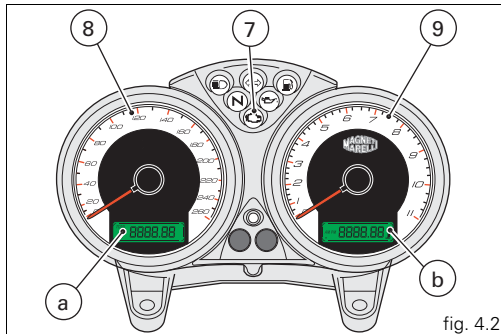

fig. 4.2

LCD functions

When the engine is switched on (key turned from **OFF** to **ON**), the instrument panel checks all instruments (dials, display, warning lights), see (fig. 5 and fig. 6).

LCD functions (1)

By pressing button (A, fig. 6) with the key turned to **ON**, you can cycle between display of the trip counter and the odometer and, if the fuel level warning light is on, the fuel reserve trip counter.

Resetting the trip meter

If button (A, fig. 6) is held pressed for more than 2 seconds while the **TRIP** (trip meter) is active, the display is reset (LCD 1).

LCD unit functions (2)

If button (B, fig. 6) is pressed with the ignition key at **ON**, the display shows the clock and the oil temperature.

Setting the clock

Press (B, fig. 6) for at least 2 seconds and the time will be shown in display (b, fig. 4.2).

Select AM/PM by pressing button (A, fig. 6). Press button (B) to select the hour setting function. Press (A) repeatedly to change the hour indication. Press button (B) to change to the minute setting function.

Press button (A) to increase the minutes; hold the button pressed for more than 5 seconds to increase the rate of change. Press button (B) to exit the clock setting function.

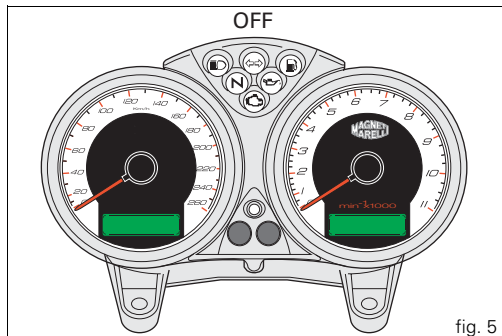

fig. 5

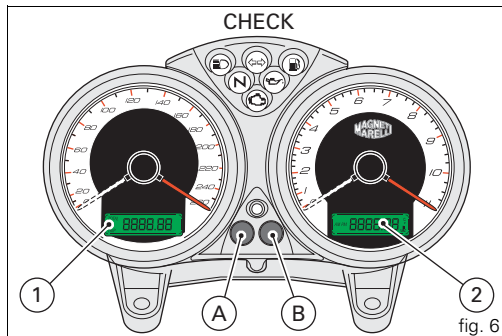

fig. 6

Oil temperature function

If the oil temperature falls below 50 °C /122 °F the word "LO" will be displayed, whereas if the temperature rises above 170 °C/338 °F, the word "HI" will appear.

Fuel level warning light

When the fuel level warning light the word "FUEL" will appear on display (2, fig. 6) and the fuel reserve trip counter function will be activated and indicate on display (1, fig. 6) the number of kilometres travelled in reserve preceded by the letter "F" (FUEL).

Maintenance indicator function

The appearance of the message "MAInt" on the display (1, fig. 6) indicates that the recommended service interval has expired: this message will be displayed each time the key is turned to "ON" for a period of 5 seconds. When you see this message, you should contact your Ducati dealer or authorised service centre.

Display backlight

Press button (B, fig. 6) within 5 seconds after the ignition key is turned to the ON position to adjust the brightness of the backlight. The brightness changes at each press of the button.



Warning

Any adjustments to the instrument panel must only be carried out when the motorcycle is stationary. Never operate the instrument panel controls while riding the motorcycle.

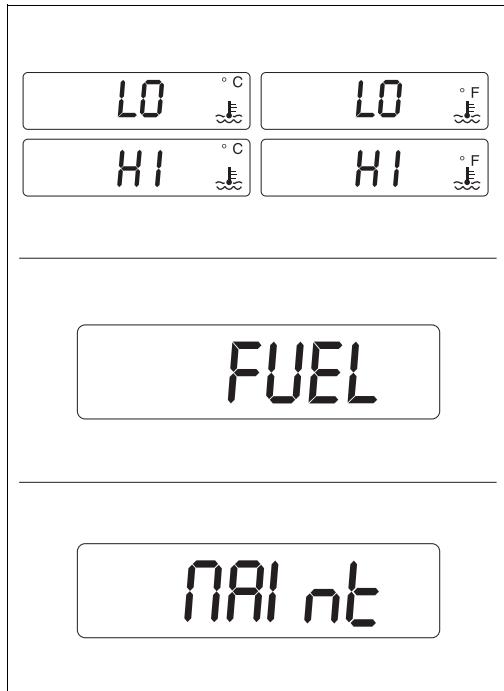

Automatic headlight switch-off function (not on USA version)

This function helps reduce battery use by automatically switching off the headlight.

The device is triggered in two cases:

- in the first case, if you turn the key from OFF to ON and do not start the engine, After 60 seconds the headlight will be deactivated and will only be reactivated the next time the key is turned from OFF to ON or the engine is started.
- in the second case, after normal use of the motorcycle with the lights on, if the engine is killed using the ENGINE STOP switch (1, fig. 14.1). In this case, 60 seconds after the engine is stopped, the headlight will be turned off and will only be turned on again the next time the engine is started.



Notes

Also during engine starting, the system turns the headlight off and turns it back on once the engine has started.

The immobilizer system

For additional anti-theft protection, the motorcycle is equipped with an IMMOBILIZER, an electronic system that locks the engine automatically whenever the ignition switch is turned off.

The handgrip of each ignition key contains an electronic device that modulates the output signal from a special antenna in the switch when the ignition is switched On. The modulated signal represents the "password" (which is changed at each start-up) by which the ECU recognizes the ignition key. The ECU will only allow the engine to start if it recognises this password.

Keys (fig. 7)

The owner receives a set of keys, comprising:

- 1 key A (RED)

The red key is a service tool and is part of the motorcycle's immobilizer system. It contains the code of the immobilizer system and should not be used for normal everyday use of your motorcycle. Your dealer may ask you to produce the red key in order to carry out certain service operations. For security reasons, the red key cannot be replaced. In cases where the red key is required for servicing purposes and the owner is unable to produce it, it will be necessary to renew the motorcycle's electronic control unit, instrument panel and ignition switch assembly, and the cost of these operations will be met by the owner. It is therefore important to keep the red key in a safe place.

- 2 keys B (BLACK)



Warning

The red key (A) has a rubber sleeve to keep it in perfect condition and to prevent contact with other keys. Never remove this protection unless absolutely necessary.

The B keys are the keys for normal use, and are used to:

- start the engine
- open the lock on the fuel tank filler cap
- open the seat lock.

The A key performs all the same functions as the B keys and it can also be used to reset and re-program other black keys if necessary.

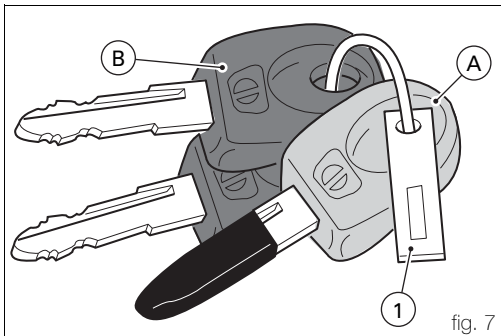



Notes

The three keys are supplied attached to a small tag (1, fig. 7) bearing their identification number.



Warning

Keep the keys separate, and store the tag (1, fig. 7) and key A in a safe place. It is also advisable to use only one of the black keys to start the motorcycle.

Code card

The keys come with a CODE CARD (fig. 8), which shows: the electronic code (A, fig. 9) to be used if the engine is locked, and if the engine fails to start when the key is at **On**.



Warning

Keep the CODE CARD in a safe place. It is advisable to always carry the electronic code shown on the CODE CARD with you when using the motorcycle, in case it is necessary to override the engine immobilizer by means of the procedure that uses the throttle twistgrip. In the event of faults in the immobilizer system, the following procedure makes it possible to disable the “engine lock” function, which is indicated by the yellow-amber EOBD warning light (7, fig. 4.1). This operation is only possible with the electronic code shown on the code card.

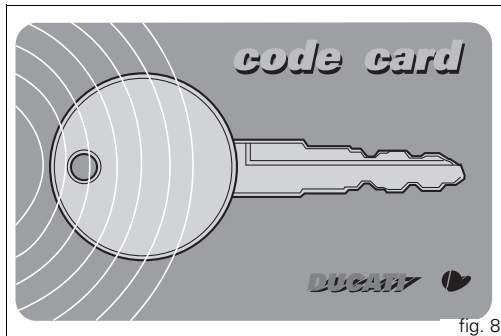

fig. 8

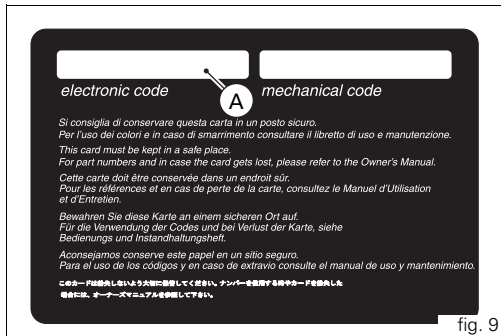

fig. 9

Procedure to override the immobilizer using the throttle twistgrip

- E
- 1) Turn the key to ON, fully open the throttle and hold it open.
The EOBD warning light (7, fig. 4.1) will go off after the pre-set time of 8 seconds.
 - 2) Release the throttle as soon as the EOBD warning light turns off.
 - 3) Now enter the electronic release code shown on the CODE CARD given to the customer when the motorcycle was handed over by the dealer. The EOBD warning light will light up and start flashing.
Count the number of flashes of the EOBD (7, fig. 4.1) light equal to the first number of the secret code.
Turn the throttle twistgrip to the fully open position: the digit entered is acknowledged, and the EOBD warning light comes on and stays on for the pre-set time of 4 seconds.
If no operation is performed with the throttle twistgrip, the EOBD light will flash 20 times and then illuminate steadily. In this case, repeat the procedure from step (1).
 - 4) Release the throttle as soon as the EOBD warning light turns off.
 - 5) Repeat the operations in steps 3 and 4 until the last digit has been entered.
 - 6) When you release the throttle, if the code was entered correctly, the EOBD light will flash to indicate that the engine is unlocked. The EOBD light returns to its normal state (off) after 4 seconds. If the code was NOT entered correctly, the EOBD light will remain lit and the procedure can be repeated as many times as necessary by turning the key to OFF, then re-starting from step (1).



Notes

If you release the twistgrip too soon, the warning light comes on again. Return the ignition key to OFF and repeat the procedure from step 1.

Operation

When the ignition key is turned from ON to OFF, the immobilizer system activates the engine lock. When the ignition key is turned from OFF to ON to start the engine:

- 1) if the code is recognised, the warning light (6, fig. 4.1) on the instrument panel will flash briefly. This means that the immobilizer system has recognised the code and disabled the engine lock. When you press the START (3, fig. 14.1) button, the engine will start up.
- 2) If either the warning light (6, fig. 4.1) or the EOBD light (7, fig. 4.1) remain lit, the code has not been recognized. In this case, it is advisable to turn the ignition key back to OFF and then to ON again. If the engine still does not start, try using another black key. If the engine still does not start, contact your DUCATI Service Centre.
- 3) If the warning light (6, fig. 4.1) keeps flashing, it means that an error signal from the immobilizer system has been cleared (e.g. with the override procedure using the throttle twistgrip). Turn the key to OFF and back to ON; the immobilizer light should return to its normal state (see step 1).



Warning

Sharp knocks can damage the electronic components inside the key.

Always use the same key during the procedure. The use of different keys could prevent the system from recognizing the code in the inserted key.

Duplicate keys

If you need additional keys, contact your DUCATI Service Centre with all the keys you have in your possession and your CODE CARD.

DUCATI Service will program new keys and re-program your original keys, up to a maximum of 8 keys.

DUCATI Service may ask for proof that you are the legitimate owner of the motorcycle.

The codes for any keys not present during the memory programming procedure are cancelled, to ensure that any keys that may have been lost can no longer be used to start the engine.



Notes

If you sell your motorcycle, do not forget to give all keys and the CODE CARD to the new owner.

Ignition switch and steering lock (fig. 10)

This is located in front of the fuel tank and has four positions:

- A) **ON**: enables lights and engine operation;
- B) **OFF**: disables lights and engine operation;
- C) **LOCK**: the steering is locked;
- D) **P**: sidelight and steering lock.

Notes

To move the key to the last two positions, push it in before turning. The key can be removed in positions (B), (C) and (D).

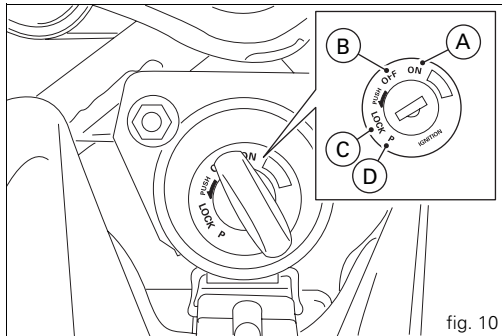





fig. 10

Left-hand handlebar switch (fig. 11)

1) Dip switch, two-position light selector switch:

position  = low beam on;

position  = high beam on.

2) Button  = three-position turn signal:

centre position = off;

position  = left turn;

position  = right turn.

To cancel the turn signals, press the control switch once it has returned to the central position.

3) Button  = horn.

4) Button  = high beam flasher.

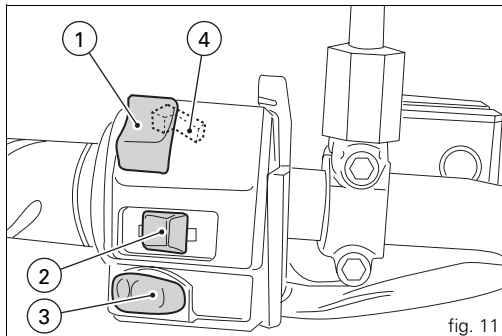

fig. 11

Clutch lever (fig. 12)

When the clutch lever (1) is operated, drive from the engine to the gearbox and the rear wheel is disengaged. Correct use of the clutch lever is very important in all riding situations, especially when moving off.

E

Important

Using the clutch properly will prolong the life of the engine and prevent any damage to components in the transmission.

Notes

The engine can be started with the sidestand down and the gearbox in neutral. If starting with a gear engaged, pull in the clutch lever (in this case the sidestand must be up).

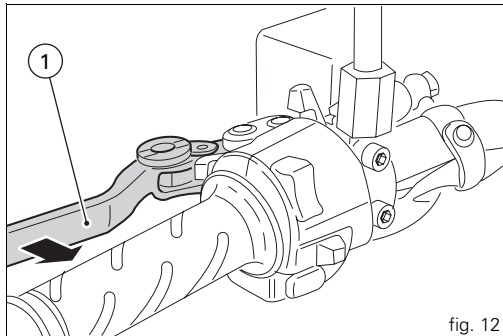

fig. 12

Cold start lever (fig. 13)

The cold start lever is used to assist starting from cold and to raise the idle speed after starting.

Lever positions:

A) = lever not activated;

B) = lever fully applied.

The lever can be placed in intermediate positions to help the engine warm up gradually (see page 39).

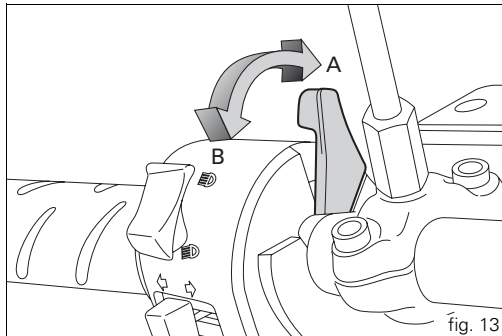

Important

Never use the cold start lever when the engine is warm.
Do not ride the motorcycle with the cold start lever activated.



E

Right-hand handlebar switch (fig. 14.1)

- 1) **ENGINE STOP** switch, with two positions:
position  (**RUN**) = run;
position  (**OFF**) = stop engine.



Warning

This switch is mainly intended for use in emergencies when you need to stop the engine quickly. After stopping the engine, return the switch to the  position to enable starting.



Important

Travelling with the headlight, switching off the engine with switch (1) and leaving the ignition key in the **ON** position can drain the battery, as the headlight remains on.

- 2) Button  = engine start.

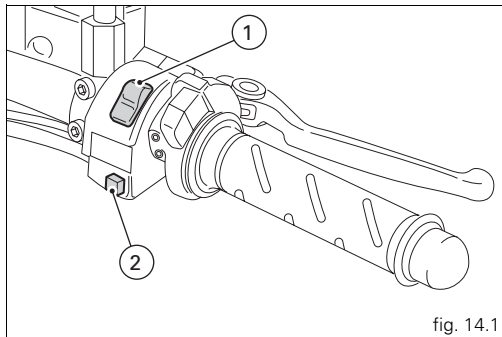

fig. 14.1

Throttle twistgrip (fig. 14.2)

The twistgrip (1) on the right handlebar opens the butterfly valves in the throttle body. When released, the twistgrip returns automatically to the initial position (idling speed).

Front brake lever (fig. 14.2)

Pull the lever (2) towards the twistgrip to operate the front brake. The system is hydraulically assisted and you only need to pull the lever gently.



Warning

Before using these controls, read the instructions on page 41.

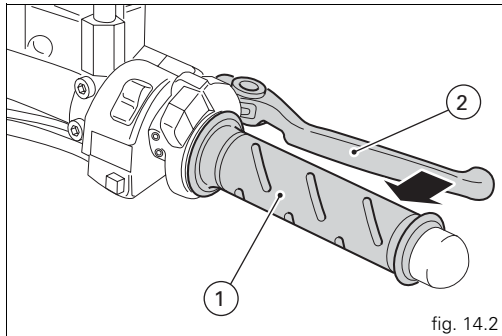

Rear brake pedal (fig. 15)

Push down on the pedal (1) with your foot to operate the rear brake.

The system is controlled hydraulically.

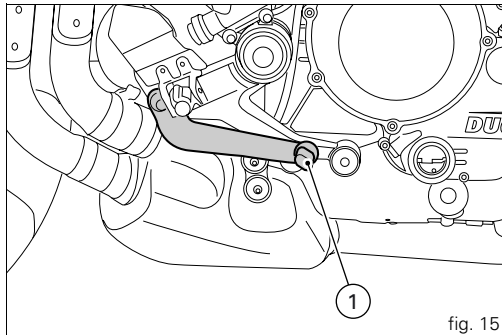

fig. 15

Gearchange pedal (fig. 16)

The gearchange pedal has a central position **N**, with automatic return, and two directions of movement:
down = push down on the pedal to engage 1st gear and to shift down. At this point the **N** warning light on the instrument panel will go off;

up = lift the pedal to engage 2nd gear and then 3rd, 4th, 5th and 6th gears.

Each time you move the pedal you engage the next gear, one gear at a time.

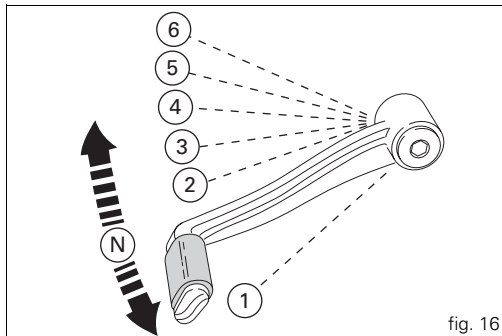

fig. 16

Adjusting the position of the gearchange pedal (fig. 17)

The position of the gearchange pedal relative to the footrest can be adjusted to suit the requirements of the rider.

To adjust the position, proceed as follows:

Hold the rod (1) using an open-ended wrench (2) and slacken off the locknuts (3) and (4).



Notes

The locknut (4) has a left-hand thread.

Turn the rod (1) and move the pedal to the required position.
Tighten both nuts against the rod.

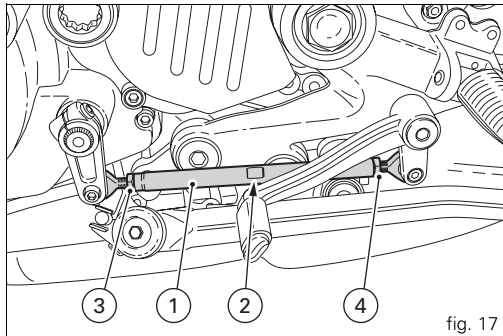

Adjusting the position of the rear brake pedal (fig. 18)

The position of the rear brake lever relative to the footrest can be adjusted to suit the requirements of the rider.

To adjust the position of the rear brake pedal, proceed as follows:

Loosen the locknut (5).

Turn the pedal travel adjustment bolt (6) until the pedal is in the desired position.

Tighten the locknut (5).

Operate the pedal by hand to check that there is 1.5 - 2 mm of freeplay before the brake bites.

If not, adjust the length of the master cylinder pushrod as follows.

Slacken off the locknut (7) on the pushrod.

Screw the pushrod (8) into the clevis (9) to increase the freeplay, or screw it out to reduce it.

Tighten the locknut (7) and recheck the pedal freeplay.

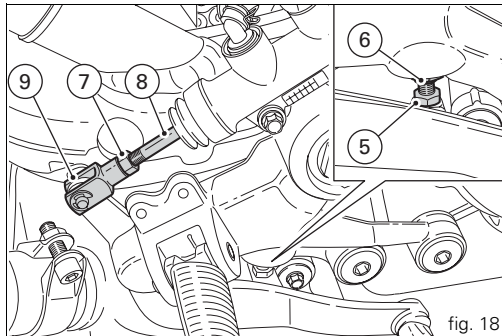

Main components and devices

Position on motorcycle (fig. 19)

- 1) Fuel tank filler cap
- 2) Seat lock
- 3) Helmet cable pin
- 4) Passenger grabhandle
- 5) Sidestand
- 6) Rear-view mirrors
- 7) Rear shock absorber adjusters
- 8) Front fork adjuster
- 9) Tank support strut
- 10) Seat cover
- 11) Fuel tank release lever
- 12) Headlight shell
- 13) Catalytic converter.

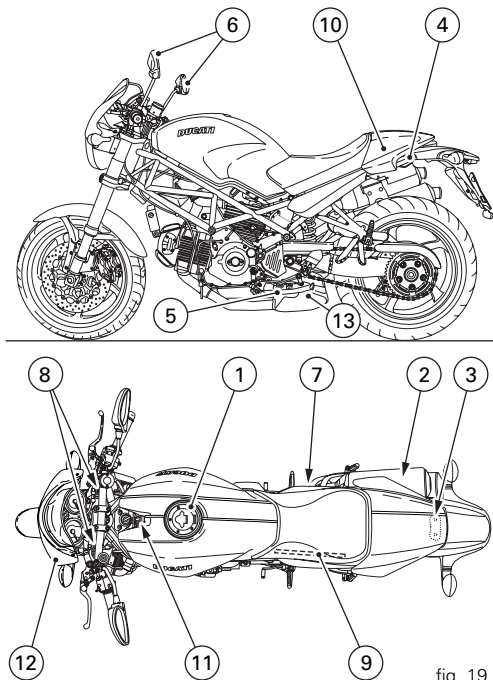

fig. 19

Fuel tank filler cap (fig. 20)

Opening

Raise the cover (1) and insert the key into the lock. Give the key a 1/4 turn clockwise to unlock.

Lift the cap.

Closing

Close the cap with the key inserted and push it into its seat. Turn the key anticlockwise to the initial position and remove it. Replace the lock cover (1).



Notes

The cap can only be closed with the key inserted.



Warning

Always make sure you have properly closed the fuel filler cap after refuelling (see page 43).

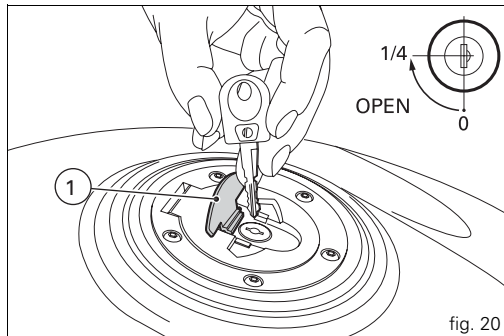

fig. 20

Seat lock and helmet holder

Opening

Insert the key in the lock and turn it clockwise to release the seat from the frame. Pull the seat backwards to release it from the front catches.

The helmet cable (1) is located at the rear of the compartment under the seat (see page 45). Pass the cable through the helmet and insert the end of the cable in the pin (2). Leave the helmet hanging and refit the seat to hold it in place.



Warning

This device protects the helmet against theft when the motorcycle is parked. Do not leave the helmet attached in this way when riding the motorcycle, as it can interfere with your movements and cause loss of control of the motorcycle.

Closing

Make sure all parts are correctly arranged and secured in the underseat compartment. Insert the front ends of the seat base under the U bolt in the frame, then push the rear end of the seat until you hear the bolt in the lock click into place. Check that the seat is firmly secured to the frame and remove the key from the lock.

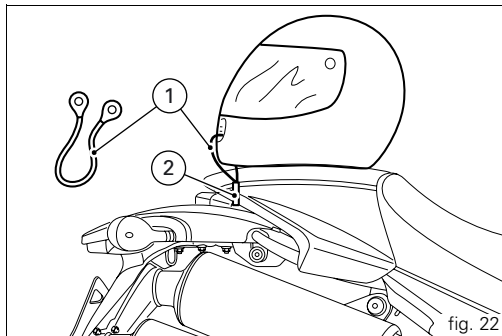
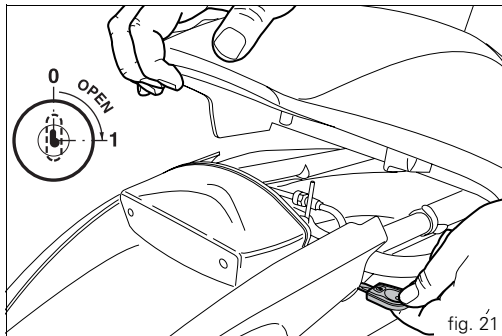

Sidestand (fig. 23)

Important

Before lowering the sidestand, check that the ground is sufficiently even and hard.

Do not park on soft or pebbled ground or on asphalt melted by the sun etc. or the motorcycle may fall over.

When parking on a slope, always park with the rear wheel on the downhill side.

To lower the sidestand, hold the motorcycle handlebars with both hands and push down on the stand (1) with your foot until it is fully extended. Tilt the motorcycle until the sidestand is resting on the ground.

Warning

Do not sit on the motorcycle when it is supported on the sidestand.

To raise the sidestand to rest position (horizontal position), tilt the motorcycle to the right and, at the same time, lift the stand (1) with your foot.

Notes

It is advisable to check periodically that the stand mechanism (consisting of two springs, one inside the other) and safety sensor (2) are working properly.

Notes

The engine can be started with the sidestand down and the gearbox in neutral. If starting with a gear engaged, pull in the clutch lever (in this case the sidestand must be up).

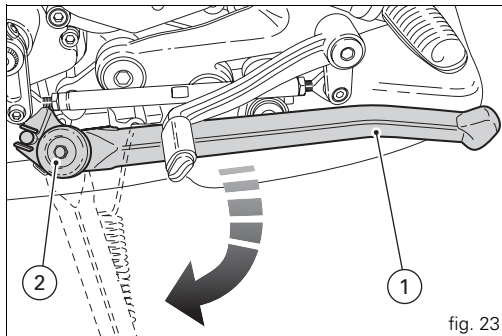

fig. 23

Rear shock absorber adjusters

The rear shock absorber has external adjusters that allow you to adjust the rear suspension to suit different load conditions. The adjuster (1), located on the right-hand side of the shock absorber at the lower end where it is attached to the swingarm, is used to set the rebound damping.

Turn the adjuster (1) clockwise to stiffen the damping **H** and anti-clockwise to soften it **S**.

STANDARD setting:

starting with the adjuster screwed fully clockwise, unscrew the adjuster (1) 18 clicks.

Spring preload: 25 mm

The two nuts (2) on the upper part of the shock absorber serve to adjust the spring preload on the external spring.

To change the spring preload, turn the upper nut. Preload is increased or reduced by screwing the lower nut in or out. STANDARD length of the preloaded spring on the shock absorber: 157 mm.



Warning

Use a pin wrench to turn the preload adjusting nut. Take special care when turning the nut, to avoid injuring your hand by striking it violently against other parts of the motorcycle if the wrench suddenly slips off the nut while turning.

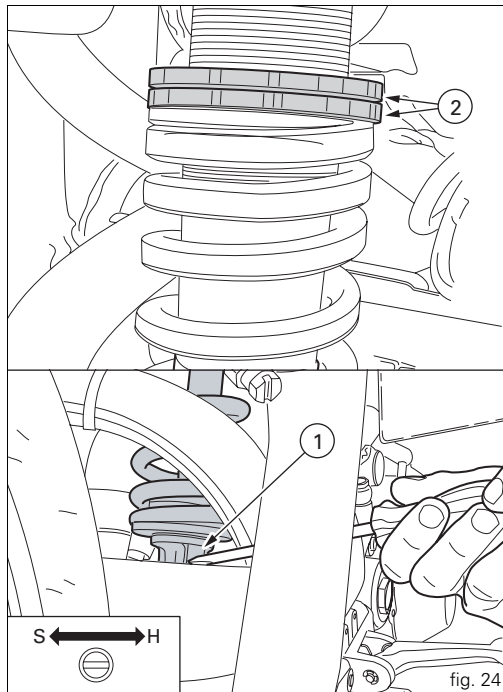



Warning

The shock absorber is filled with gas under pressure and may cause severe injury if dismantled by untrained persons.

If you plan to carry a passenger and luggage, adjust the rear shock absorber spring load to the maximum setting to improve the handling characteristics of the motorcycle and to avoid the possibility of ground contact. It may also be necessary to adjust the rebound damping accordingly.

E

Adjusting the rear ride height

(fig. 25-fig. 26-fig. 27)

The standard ride height setting is the result of tests carried out in a wide variety of conditions by our technical staff. Modifying the frame geometry is a very critical operation, and can be dangerous if carried out by untrained persons. Before changing the standard setting, measure the reference value (H, fig. 25).

The rider can adjust the rear ride height to suit his/her needs by changing the working position of the rear shock absorber. To alter the eye to eye length of the tie-rod (1), slacken the locknuts (3).

Notes

Note that the lower nut (3) has a left-hand thread.

Rotate the tie-rod (2) with an open-ended wrench. Once the tie-rod length is adjusted correctly, tighten the nuts (3) to 25 Nm.

Warning

The length of the tie-rod (2) between the centres of the two eyes (1) should not exceed 272 mm.

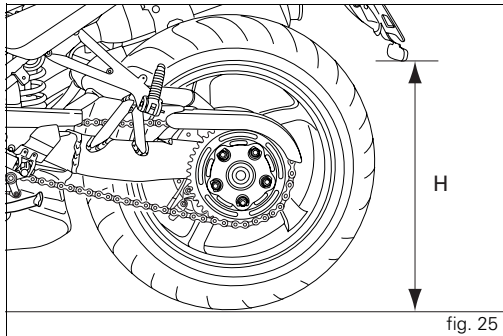

fig. 25

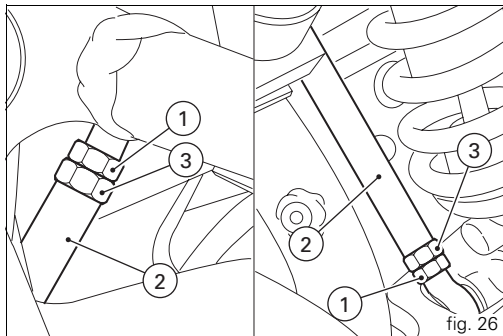
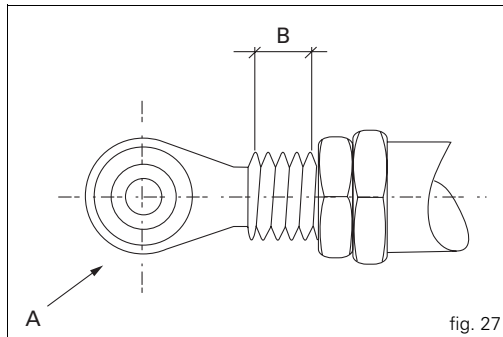

fig. 26

The maximum distance that the UNIBALL end fitting (A) can be unscrewed from the tie-rod body is 5 threads, or 7.5 mm (B).

E



Riding the motorcycle

Running-in recommendations

Max. engine speed (fig. 28)

Rpm limits to be observed during the running-in period and in normal use:

- 1) up to 1000 km;
- 2) from 1000 to 2500 km.

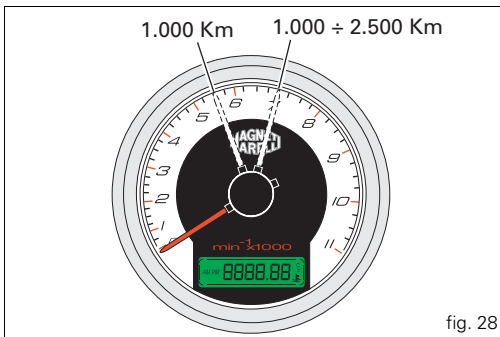

fig. 28

Up to 1000 km

During the first 1000 km, keep an eye on the tachometer. The revs should never exceed: 5500-6000 rpm.

During the first hours of riding, it is advisable to continuously vary the load on the engine and the rpm, though still keeping within the above limits.

For this reason, roads with numerous bends and hilly areas are ideal for running in the engine, brakes and suspension.

For the first 100 km use the brakes gently. Avoid sudden or prolonged braking. This will allow the friction material on the brake pads to bed in against the brake discs.

To allow all the mechanical moving parts in the motorcycle to adapt to one another, and to avoid shortening the life of the main engine components, it is advisable to avoid sudden acceleration and running the engine at high rpm for too long, especially uphill.

It is also advisable to check the drive chain frequently and ensure that it is lubricated as required.

From 1000 to 2500 km

You can take more power from the engine, but you should never go above 7000 rpm.

Important

Throughout the running-in period, be careful to stick to the recommended maintenance schedule and periodic service intervals indicated in the warranty booklet. Failure to follow these instructions will release Ducati Motor Holding S.p.A. from any liability for any engine damage or shortened engine life.

E

Keeping to the running-in recommendations will ensure longer engine life and reduce the need for overhauls and re-tuning.

Pre-ride checks

Warning

Failure to carry out these checks before starting may result in damage to the motorcycle and injury to rider.

Before starting, check the following points:

Fuel level in the tank

Check the fuel level in the tank. Re-fuel if necessary (page 43).

Engine oil level

Check the oil level in the sump through the sight glass. Top up if necessary (page 63).

Brake and clutch fluid

Check the fluid levels in the respective reservoirs.

Tyre condition

Check the pressure and condition of the tyres (page 61).

Controls

Operate the brake, clutch, gearchange and throttle controls (lever, pedal and twistgrip) and check that they function correctly.

Lights and indicators

Check that lights, indicators and horn are working properly. Replace any burnt-out bulbs (page 56).

Key locks

Check that the fuel filler cap and the seat are locked.

Sidestand

Make sure the sidestand operates smoothly and is in the correct position (page 32).

Warning

If there are any faults or malfunctions, do not start the motorcycle and contact your DUCATI Dealer or Authorized Service Centre.

Starting the engine



Notes

Follow the "High ambient temperature" procedure to start the engine when it is already warm.



Warning

Before starting the engine, familiarise yourself with the controls that you will use when riding.

Normal ambient temperature

(between 10 °C/50 °F and 35 °C/95 °F):

1) Turn the ignition key to **ON** (fig. 29). Check that both the green light **N** and the red light  on the instrument panel come on.



Important

The oil pressure warning light should go out a few seconds after the engine has started (page 11).



Warning

The sidestand should be in rest position (horizontal), otherwise the safety sensor prevents the engine starting.



Notes

The engine can be started with the sidestand down and the gearbox in neutral. If starting with a gear engaged, pull in the clutch lever (in this case the sidestand must be up).

2) Move the cold start lever to (B, fig. 31).

3) Check that the stop switch (1, fig. 30) is set to (RUN), then press the start button (2, fig. 30).

This model has servo-assisted starting. To use the servo-assisted starting feature, press the start button (2) and release it immediately. When you press button (2) the starter motor runs automatically for a period of time that varies according to the engine temperature. The system disengages the starter motor as soon as the engine starts. If the engine fails to start, wait at least 2 seconds before pressing the start button (2) again.

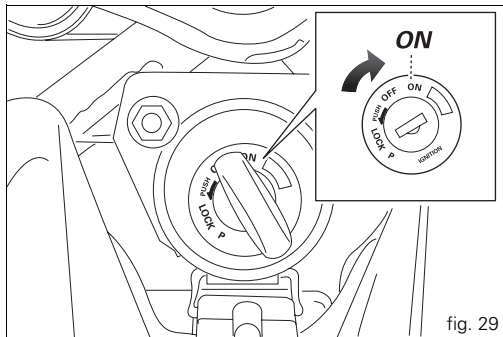

fig. 29

Allow the engine to start on its own, without turning the throttle.

Notes

If the battery is flat, the system automatically disables operation of the starter motor.

4) Move the starter lever towards the vertical position (A) to obtain an idle speed of 1400 to 1500 rpm.

Important

Do not rev the engine when cold. Allow some time for the oil to warm up and reach all points that need lubricating.

5) Then, as the engine warms up, move the cold start lever gradually towards vertical position (A, fig. 31). Once the engine is at normal running speed, it should idle smoothly with the cold start lever completely closed.

High ambient temperature (above 35 °C/95 °F):

Follow the same procedure for 'Normal ambient temperature', but without using the cold start lever.

Cold ambient temperature (below 10 °C/50 °F):

Follow the procedure for 'Normal ambient temperature', but allow up to 5 minutes for the engine to warm up (point 5).

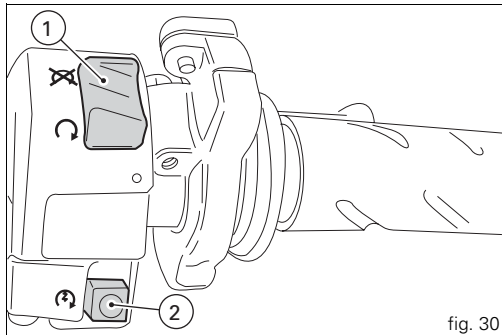

fig. 30

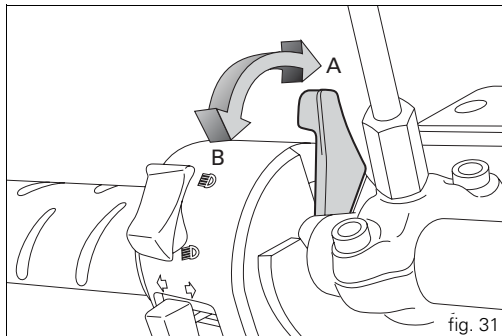

fig. 31

Moving off

- 1) Disengage the clutch by squeezing the clutch lever.
- 2) Push down the gearchange lever firmly with the tip of your foot to engage first gear.
- 3) Raise the engine revs by turning the throttle twistgrip while gradually releasing the clutch lever. The motorcycle will start moving.
- 4) Release the clutch lever completely and accelerate.
- 5) To change to second gear, close the throttle to reduce the engine revs, disengage the clutch, lift the gearchange lever and release the clutch lever.

To change down, proceed as follows: release the twistgrip, disengage the clutch, briefly accelerate the engine to allow the gears to synchronize, shift down and release the clutch. Use the controls intelligently and opportunely: when riding uphill, change down immediately when the motorcycle begins to slow down, to avoid abnormal stresses on the motorcycle structure as well as on the engine.



Important

Avoid sudden acceleration, as this may lead to misfiring and transmission snatching. The clutch lever should not be held in longer than necessary after a gear is engaged, otherwise friction parts may overheat and wear out.

Braking

Slow down in time, change down to use the engine brake, then apply both brakes. Pull in the clutch lever before the motorcycle comes to a stop to prevent the engine stalling.



Warning

E Use both the brake lever and the brake pedal for effective braking. Using only one of the brakes will give you less braking power. Never use the brake controls harshly or suddenly as you may lock the wheels and lose control of the motorcycle. When riding in the rain or on slippery surfaces, braking capacity is significantly reduced.

Always use the brakes very gently and carefully when riding under these conditions. Any sudden manoeuvres may lead to loss of control.

When riding down long, steep downhill slopes, change down to use engine braking. Apply the brakes intermittently for brief periods only. Keeping the brakes applied continuously causes the friction material to overheat and dangerously reduces braking effectiveness. Under-inflated tyres reduce braking efficiency and may adversely affect handling and road-holding on bends.

Stopping the motorcycle

Reduce speed, change down and release the throttle twistgrip. Change down to engage first gear and then neutral. Apply the brakes and bring the motorcycle to a complete stop. Switch the engine off by turning the key to **OFF** (page 20).



Important

Do not leave the key in the ON position when the engine is off to avoid damaging the electrical components.

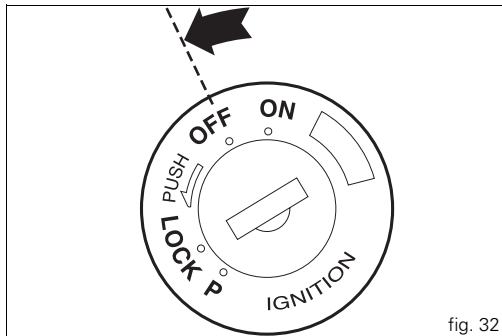

fig. 32

Refuelling

Do not overfill the tank when refuelling. The fuel level should always be below the rim of the filler cap recess (fig. 33).



Warning

Use fuel with low lead content and an original octane number of at least 95. Check that no fuel is trapped in the filler cap recess.

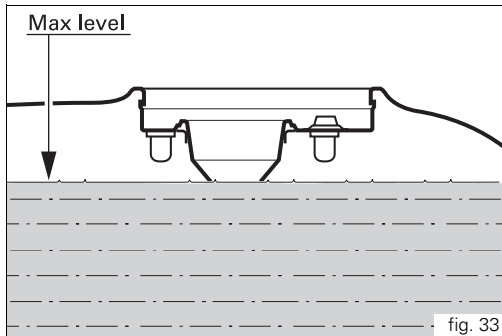

fig. 33

Parking

Stop and park the motorcycle on the side stand (see page 32). To prevent theft, turn the handlebar fully left and turn the ignition key to the **LOCK** position.

If you park in a garage or other indoor area, make sure that there is proper ventilation and that the motorcycle is not near a source of heat.

If necessary, you can leave the side lights on by turning the key to position **P**.

E

Important

Do not leave the key at **P** for long periods or the battery will run down. Never leave the motorcycle unattended with the ignition key inserted.

Warning

The exhaust system might still be hot even if the engine is switched off; take special care not to touch exhaust system with any part of your body and do not park the motorcycle next to inflammable material (wood, leaves etc.).

Warning

Using padlocks or other locks designed to prevent movement of the motorcycle (such as brake disc locks, rear sprocket locks, and so on) is very dangerous, and may impair motorcycle operation and the safety of rider and passenger.

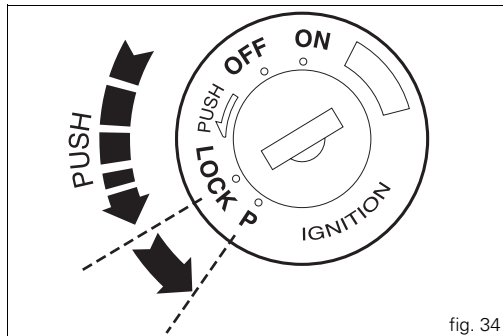

fig. 34

Toolkit and accessories (fig. 35)

The underseat compartment contains:
use and maintenance manual;
helmet fastening cable;
toolkit for routine maintenance operations and checks.

To access the compartment, you need to remove the seat (page 31) and remove the cover (1) unscrewing the special screw with a coin.

Toolkit (fig. 36)

Contains:

- 3) spark plug wrench;
- 4) tommy bar for spark plug wrench;
- 5) double-ended screwdriver;
- 6) helmet fastening cable;

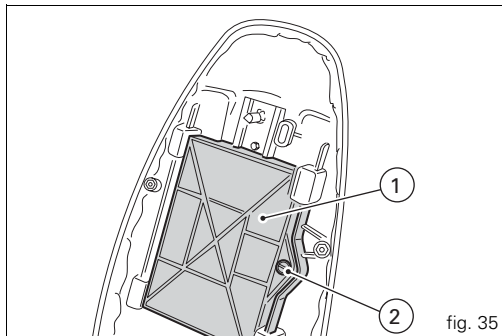

fig. 35

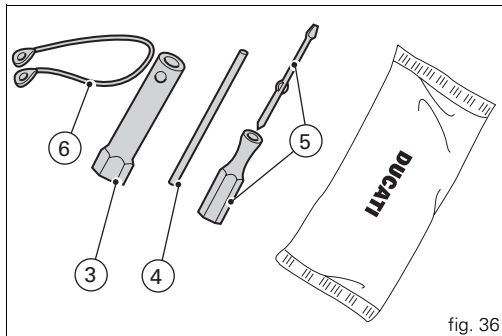

fig. 36

Main Maintenance Operations

E

Removing the fairing panels (S2R) (fig. 37)
Some parts of the motorcycle fairing have to be removed for certain maintenance or repair operations.

Warning

If parts that have been removed are not refitted correctly they may become loose suddenly while riding and cause you to lose control of your motorcycle.

Removing the headlight shell (S2R)

Unscrew and remove the two bolts (1) securing the headlight shell to the headlight support.

Notes

Be careful not to lose the nuts for the bolts (1) located on the inside of the headlight shell.

Remove the headlight shell (2).

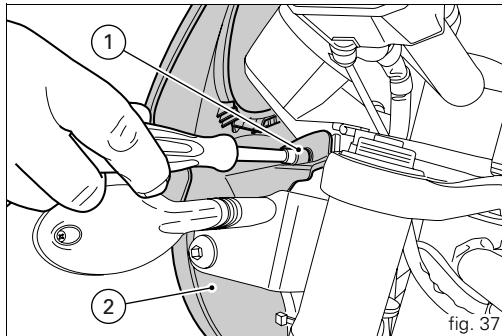

Lifting the fuel tank (fig. 38)



Warning

To prevent fuel from spilling out through the filler cap breather hole, the quantity of fuel in the tank should be less than 5 litres.

Remove the seat (page 31), release the catch (1).
Lift the tank and release the support strut (2, fig. 39) from its holder under the seat.
Rest the tank on the support strut.
To replace the tank, perform the above operations in the reverse order.



Warning

When lowering the fuel tank, take care to position the hoses correctly so they are not pinched or crushed.

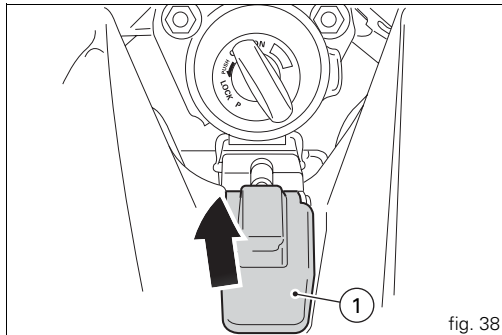

E

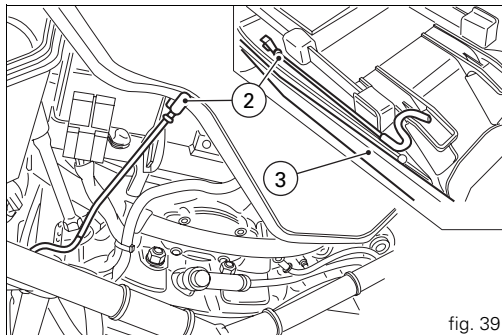

Changing the air filter

The air filter must be renewed at the intervals indicated in the periodic maintenance table shown in the Warranty Booklet. To access the airbox, lift the fuel tank as described in (page 47).

To remove the filter, release the clips (1) on both sides of the airbox cover and remove the cover (2, fig. 40).

Remove the old filter cartridge (3, fig. 41) and fit a new one.

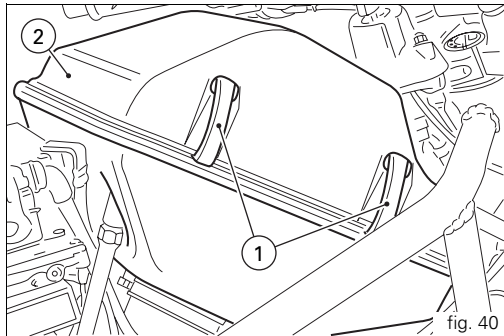

Important

A dirty filter reduces the amount of intake air, which increases fuel consumption, reduces engine power and causes deposits to form on the spark plugs. Do not use the motorcycle without a filter; as impurities in the air could get into the engine and cause damage.

Reinstall the filter correctly in its housing in the airbox, as shown in the figure, and refit all the parts originally removed.

Important

If using the machine on wet or dusty roads, the air filter cartridges should be renewed more frequently than the intervals in the periodic maintenance table in the Warranty Booklet.

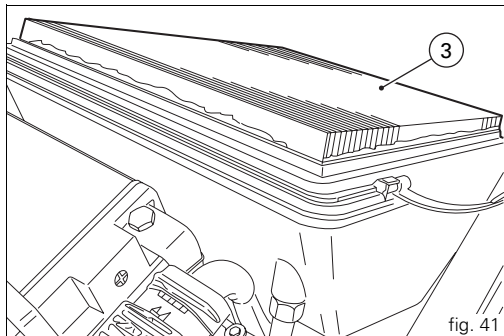

Checking the brake and clutch fluid level

(fig. 42)

The levels should not fall below the **MIN** marks on the respective reservoirs.

If the level is too low it can allow air to get into the circuit, thus impairing the efficiency of the relative system.

Brake and clutch fluid must be topped up and changed at the intervals specified in the periodic maintenance table (see Warranty Booklet) by a Ducati Dealer or Authorized Service Centre.



Important

It is recommended that all brake and clutch hoses be renewed every four years.

Clutch system

If there is too much play at the control lever and the motorcycle jumps or stops when a gear is engaged, this indicates air in the system. Contact a Ducati Dealer or Authorized Service Centre to have the system inspected and the air bled from the system.



Warning

The level of clutch fluid tends to increase in the reservoir as the friction material on the clutch plates wears out. Do not exceed the specified level (3 mm above the minimum level).

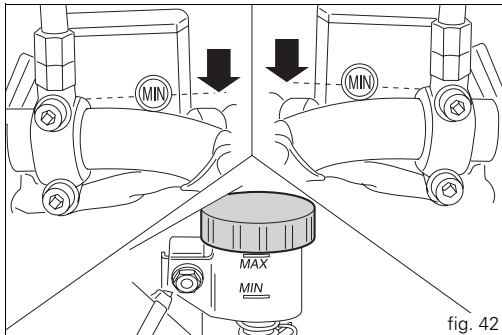

Brake system

If there is excessive play at the brake lever or pedal even though the brake pads are still in good condition, contact a Ducati Dealer or Authorized Service Centre to have the system inspected and any air expelled from the circuit.



Warning

Brake and clutch fluid is harmful to paintwork and plastic parts, so do not allow it to come into contact with them.

Hydraulic oil is corrosive and can cause damage and injuries.

Never mix different quality oils.

Check that the seals are in good condition.

Checking the brake pads for wear (fig. 43)

Front brake

The brake pads are marked with wear indicators so that they can be checked without removing them from the calipers. If the grooves in the pad friction material are still visible, the pad is still in good condition.

Rear brake

The thickness of the friction material on each pad must be at least 1 mm.



Important

Have the brake pads replaced at a Ducati Dealer or Authorized Service Centre.

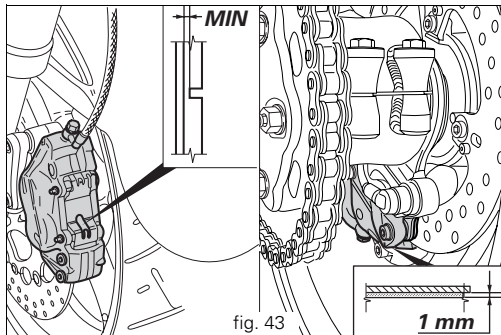

Lubricating cables and joints

The condition of the outer cables of the throttle and starter cables should be checked at regular intervals. There should be no signs of pinching or cracking on the outer plastic sheath. Operate the control to check that the inner cable slides smoothly inside the outer cable: if you feel any rubbing or catching, have the cable replaced by a Ducati Dealer or Authorized Service Centre.

To prevent problems, periodically lubricate the ends of each control cable with SHELL Advance Grease or Retinax LX2. Retinax LX2.

In the case of the throttle cable, open the twistgrip housing by unscrewing the two screws (1, fig. 44) and grease the end of the cable and the race.

Warning

Close the twistgrip housing carefully, inserting the cable in the race.

Refit the housing and tighten the screws (1) to 1.8 Nm.

To ensure smooth operation of the pivot on the sidestand, remove any dirt and apply SHELL Alvania R3 to all points subject to friction.

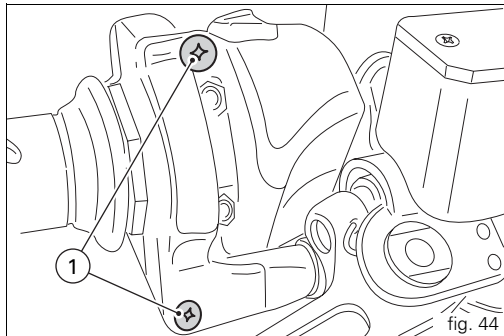

Adjusting the throttle cable

In all steering positions, the throttle twistgrip should have about 2 –4 mm of free travel, measured at the outer edge of the twistgrip housing. Adjust if necessary, using the adjuster (1, fig. 45) located on the twistgrip.

E

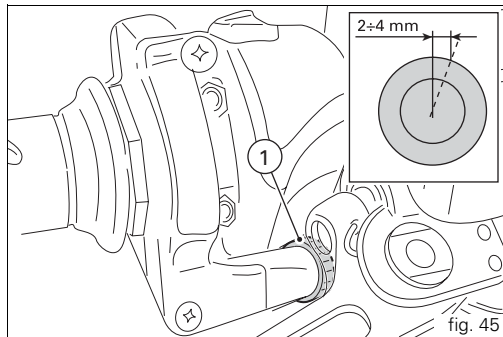

Charging the battery (fig. 46)

Before charging the battery, it is best to remove it from the motorcycle.

First disconnect the black negative terminal (-), then the red positive terminal (+).

Release the clips (1) and remove the battery.



Warning

The battery produces explosive gases: keep it away from heat sources and flames.

Charge the battery in a well-ventilated area.

Connect the battery charger leads to the battery terminals: red to the positive terminal (+), black to the negative terminal (-).



Important

Connect the battery to the charger before switching on to prevent sparks at the battery terminals that could ignite the gases inside the cells.

Always connect the red positive terminal first.



Warning

Keep the battery out of the reach of children.

Charge the battery at 1 A for 5 to 10 hours.

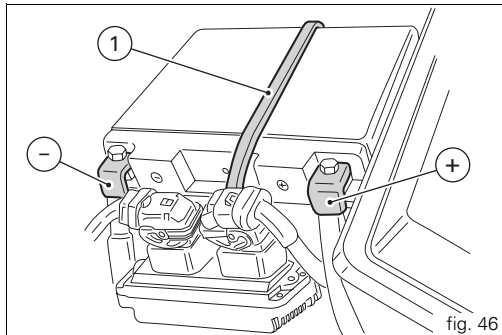

Tensioning the drive chain

Move the motorcycle slowly until you find the point at which the upper section of the chain is most taut.

Place the motorcycle on its sidestand.

Push the chain upwards with a finger in correspondence with the centre of the swingarm (see adhesive label).

The bottom run of the chain must be able to deflect 30 to 32 mm.

If not, have the chain tensioned at a Ducati Dealer or Authorized Service Centre.

Warning

For the safety of the rider, it is essential that the eccentric hub clamp bolts are correctly tightened.

Important

An incorrectly tensioned chain will cause the rapid wear of transmission parts.

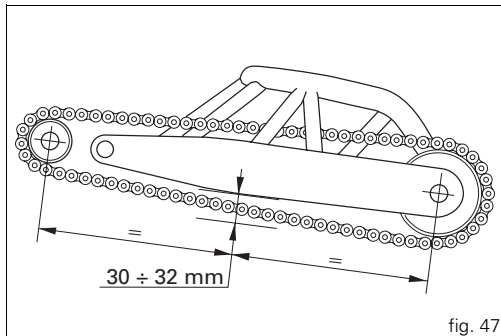

Lubrication of the drive chain

The chain fitted on your motorcycle has O-rings to protect its moving parts from dirt, and to hold the lubricant inside. So as not to damage these seals when cleaning the chain, use special solvents and avoid aggressive washing with high-pressure steam cleaners. After cleaning, blow the chain dry with compressed air or wipe with an absorbent material, then lubricate each link with SHELL Advance Chain or Advance Teflon Chain.

Important

Using non-specific lubricants may cause severe damage to the chain and the front and rear sprockets.

Replacing bulbs

Before replacing a burnt-out bulb, make sure that the new one complies with voltage and wattage as specified in the "Electrical System" paragraph on page 78.

Headlight (fig. 48, fig. 49, fig. 50, fig. 51)

To carry out maintenance on the headlight, it is advisable to remove the headlight fairing as described in the paragraph "Removing the headlight shell" on page 46.

To access the headlight bulbs, loosen the lower screw (1) that attaches the lens/reflector assembly to the shell. Disconnect the wiring connector (2, fig. 49) from the headlight bulb. Release the bulb retaining clip (3, fig. 49) and remove the bulb from its housing.

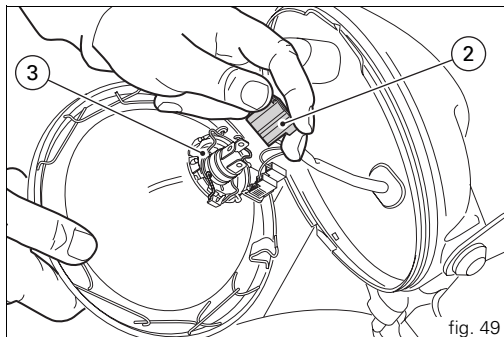
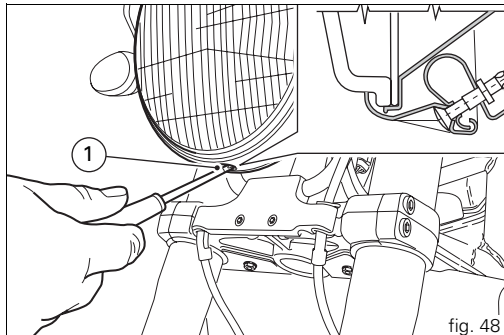

Fit a new bulb (4, fig. 50).



Notes

Do not touch the transparent part of the bulb with your fingers, this will darken it and cause a loss of brightness. Insert the tabs on the bulb base into the corresponding slots in the bulb housing to ensure the bulb is correctly positioned; hook the end of the clip (3, fig. 49) on to the headlight mountings. Reconnect the wiring.

To renew the side light bulb, detach the wiring connector. The bulb (5, fig. 51) is of the bayonet type: push it in and turn it anti-clockwise to remove it. Push the new bulb in and turn it clockwise until it clicks into place. Reconnect the wiring connector and replace the lens/reflector assembly.

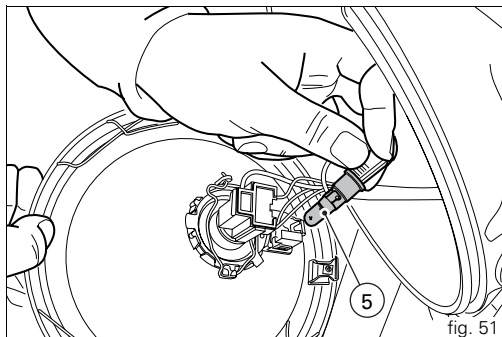
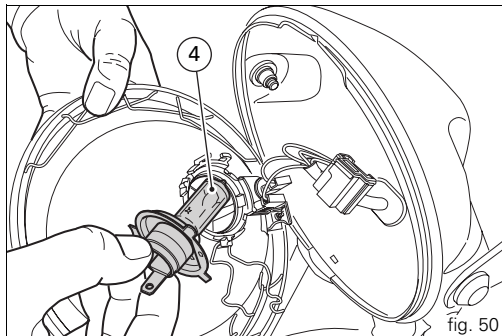

Turn signals (fig. 52)

Loosen the screw (1) and detach the lens (2) from the turn signal light.

The bulb has a bayonet-type base: to remove it, push it in and turn it counter-clockwise. Push in the new bulb and turn it clockwise until it clicks into place. Refit the lens by inserting the tab (A) in the corresponding slot in the turn signal. Refit and tighten the screw (1).

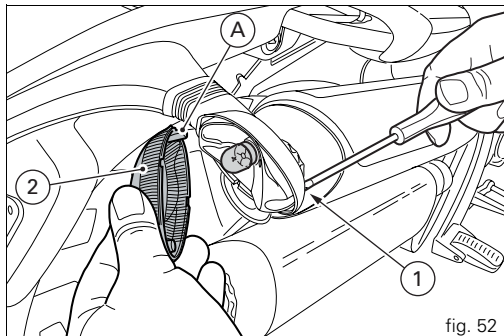

Brake light (fig. 53)

To change the brake light bulb, loosen the two screws (1) securing the lens (2) and remove it. The bulb has a bayonet-type base: to remove it, push it in and turn it counter-clockwise. Push in the new bulb and turn it clockwise until it clicks into place. Refit the lens.

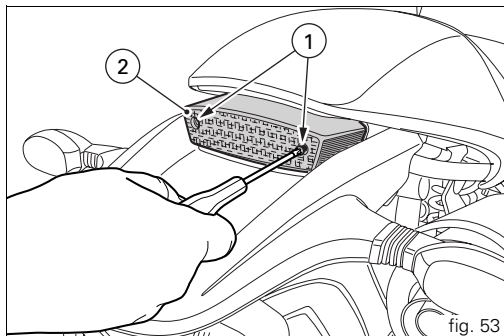

Number plate light (fig. 54)

To access the bulb in the number plate light (3), pull the bulb holder out from the light, then pull the bulb out of the holder and renew it.

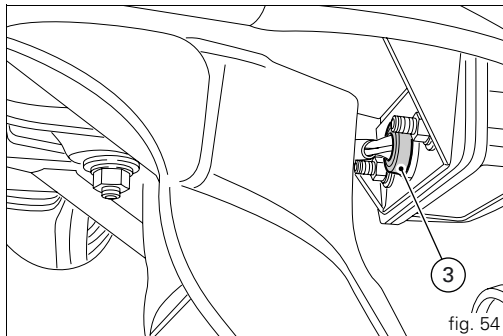

Headlight aim (fig. 55)

To check the headlight aim, place the motorcycle upright with the tyres inflated to the correct pressure and one person sitting astride the motorcycle. The motorcycle should be perfectly vertical, with its longitudinal axis at right angles to a wall or screen at a distance of 10 metres. Draw a horizontal line on the wall at the height of the centre of the headlight and a vertical one in line with the longitudinal axis of the motorcycle.

If possible, perform this check in conditions of low ambient light.

Switch on the low beam headlight.

The upper edge between the dark area and the lit area should not be above $\frac{9}{10}$ th of the height of the headlamp centre from the ground.

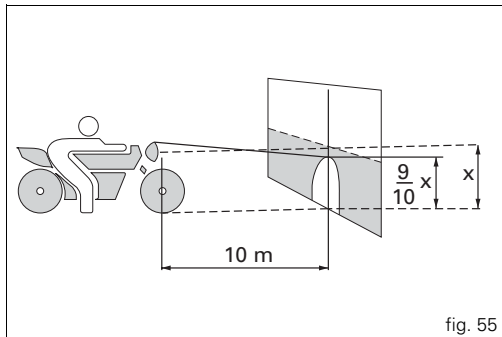

Notes

Note: this procedure is the one specified by Italian regulations for checking the maximum height of light beams. Owners in other countries should adapt this procedure to the regulations in force in the country where the motorcycle is used.

The vertical aim of the headlamp is adjusted by turning the screws (1, fig. 56) that attach it to the side mountings.

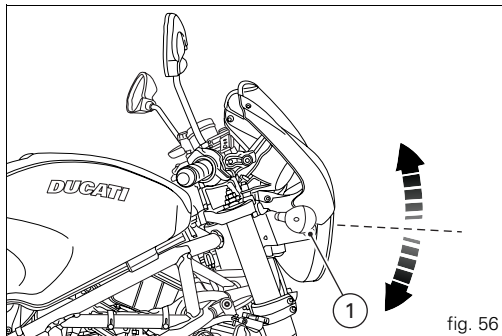

Tyres

Front tyre pressure:

2,1 bar -2.3 kg/cm²

Rear tyre pressure:

2,2 bar -2.4 kg/cm²

As tyre pressures are affected by changes in temperature and altitude, check and adjust them whenever you are riding in areas where there are large variations in temperature or altitude.

Important

Check and adjust the pressures with the tyres cold.

To prevent distortion of the front wheel rim, increase tyre pressure by 0.2 to 0.3 bar when riding on bumpy roads.

Repairing or renewing tyres

With minor punctures, tubeless tyres take a long time to deflate, as they tend to hold the air inside. If you find that one of the tyres is slightly deflated, check the tyre for slow punctures.



Warning

Punctured tyres must be renewed.

Replace with tyres of the original brand and type.

Be sure to tighten the valve dust caps securely to prevent leaks while riding. Never fit tyres with inner tubes, as these can cause the tyre to burst suddenly, with possibly serious consequences for the rider and passenger.

After renewing a tyre, the wheel must be balanced.



Important

Do not remove or alter the position of the wheel balancing weights.



Notes

If tyres need changing, contact a Ducati Dealer or Authorized Service Centre to make sure wheels are removed and refitted correctly.

Minimum tread depth

Measure the tread depth (S, fig. 57) at the point where the tread is most worn.

It should not be less than 2 mm, and in any case not less than the legal limit.

Important

Visually inspect the tyres at regular intervals for cracks and cuts, especially on the side walls, and bulges or large stains that indicate internal damage. Replace them if badly damaged.

Remove any stones or other foreign bodies stuck in the tread.

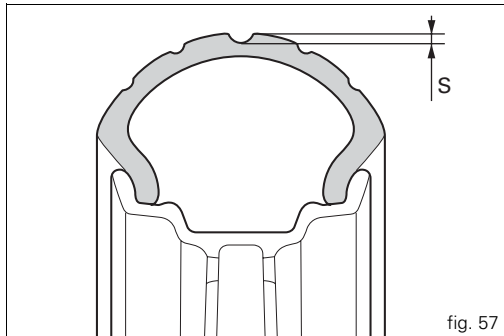

Checking the engine oil level (fig. 58)

The engine oil level can be checked through the sight glass (1) provided on the clutch cover.

Check the oil level with the motorcycle upright and the engine cold. Allow a few minutes for the oil level to stabilize after stopping the engine.

The oil level should be between the marks next to the sight glass. If the level is below the bottom mark, top up with SHELL Advance Ultra 4 engine oil.

Remove the oil filler cap (2) and top up until the oil reaches the required level. Replace the filler cap.

Important

To change the engine oil and filters at the intervals specified in the maintenance table in the Warranty Booklet, contact a Ducati dealer or Authorized Service Centre.

Oil viscosity

SAE 10W-40

The other viscosity values shown in the table can be used if the local average temperature is within the limits specified for that oil viscosity.

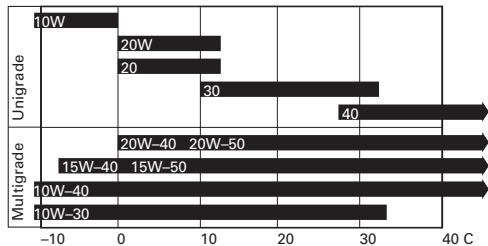
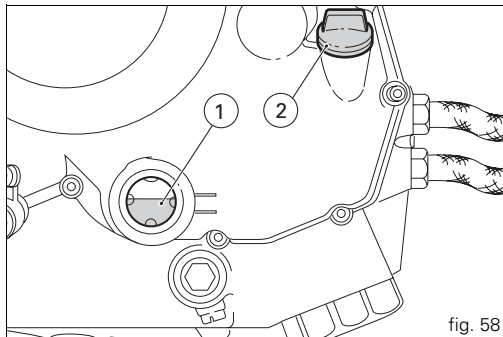

Cleaning and renewing the spark plugs

(fig. 59)

Spark plugs are an important part of the engine and should be checked at regular intervals.

This is a relatively simple operation and provides a good indication of how well the engine is running.

Pull the spark plug caps off the spark plugs and remove the plugs from the cylinder heads using the wrench supplied in the toolkit.

Check the colour of the ceramic insulation around the central electrode: an even brown colour is a sign that the engine is in good condition.

If the insulation is any other colour, or if there are dark deposits, renew the spark plug and describe the condition of the old plug to a Ducati dealer or Authorized Service Centre. Also check the central electrode; if it is worn or glazed, renew the spark plug.

Check the electrode gap, which must be: 0,6-0,7 mm.

Important

Take care when bending the side electrode to adjust the gap. A gap outside the specified limits will adversely affect engine performance and may lead to difficult starting or erratic idling.

Thoroughly clean the electrode and insulation using a wire brush, and check the condition of the washer.

Clean the spark plug seat in the cylinder head, and take care not to allow foreign objects to fall inside the combustion chamber.

Insert the spark plug in the cylinder head and screw in fully by hand. Tighten to a torque of 20 Nm.

If you do not have a torque wrench, after tightening by hand, turn the unit a further half turn with the provided wrench.



Important

Do not use spark plugs with an unsuitable heat rating or incorrect reach.

The spark plug must be tightened correctly.

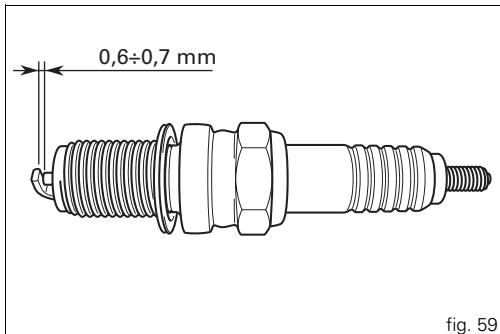

fig. 59

General cleaning

To preserve the original shine on metal surfaces and paintwork, wash and clean your motorcycle at regular intervals depending on the type of use and according to the particular road conditions. Use specific products, where possible biodegradable. Avoid aggressive detergents or solvents.



Important

Do not wash your motorcycle immediately after use, as marks can form due to evaporation of the water on hot surfaces.

Never clean the motorcycle using hot or high-pressure water jets.

Cleaning the motorcycle with high-pressure water cleaners may lead to seizure or serious faults in the front fork, wheel hub assembly, electric system, front fork seals, air inlets or exhaust silencers, with subsequent loss of the required levels of safety.

If parts of the engine are unusually dirty or greasy, use a degreasing agent, avoiding contact with transmission components (chain, front and rear sprockets, etc.). Rinse with warm water and dry all surfaces with chamois leather.



Warning

There may be loss of braking efficiency immediately after washing the motorcycle. Never grease or lubricate the brake discs. This will cause loss of braking efficiency. Clean the discs with an oil-free solvent.

Storing the motorcycle

If the motorcycle is to be left unused for a long period, it is advisable to carry out the following operations first:

clean the motorcycle;

empty the fuel tank by removing the drain plug and gasket;

pour a few drops of engine oil into the cylinders through the spark plug bores, then crank the engine by hand a few times

to form a protective film of oil on the cylinder inner walls;

place the motorcycle on the paddock stand;

disconnect and remove the battery. If the motorcycle has been left unused for more than a month, the battery should be checked and re-charged if necessary.

Protect the motorcycle with a special motorcycle cover that will not damage the paintwork or retain moisture.

This type of motorcycle cover is available from Ducati Performance.

Important notes

The legislation in some countries (France, Germany, Great Britain, Switzerland etc.) sets certain noise and pollution standards.

Periodically carry out the required checks and renew parts as necessary, using Ducati original spare parts, in compliance with the regulations in the country concerned.

Maintenance

Programmed maintenance plan operations to be carried out by the dealer

List of operations with type of intervention (distance or time interval *)	km. x1000 Months	1	12	24	36	48	60
		6	12	24	36	48	60
Change the engine oil		●	●	●	●	●	●
Change the engine oil filter		●	●	●	●	●	●
Clean the engine oil pick-up filter					●		
Check the engine oil pressure				●		●	
Check and/or adjust the valve clearances (1)			●	●	●	●	●
Check the tension of the timing belts (1)			●		●		●
Renew the timing belts				●		●	
Check and clean the spark plugs. Renew if necessary				●		●	
Check and clean the air filter (1)			●		●		●
Change the air filter				●		●	
Check throttle body synchronisation and idle speed setting (1)			●	●	●	●	●

List of operations with type of intervention (distance or time interval *)	km. x1000	1	12	24	36	48	60
	Months	6	12	24	36	48	60
Check the brake and clutch fluid level		●	●	●	●	●	●
Change the clutch and brake fluid					●		
Check and adjust the brake and clutch control cables			●	●	●	●	●
Check/lubricate the throttle/cold start cable			●	●	●	●	●
Check tyre pressure and wear		●	●	●	●	●	●
Check the brake pads. Renew if necessary		●	●	●	●	●	●
Check the steering head bearings				●		●	
Check the drive chain tension, alignment and lubrication		●	●	●	●	●	●
Check the clutch disc pack. Renew if necessary (1)			●	●	●	●	●
Check the rear wheel cush drive				●		●	
Check the wheel hub bearings				●		●	
Check the indicators and lighting			●	●	●	●	●
Check tightness of nuts and bolts securing the engine to the frame			●	●	●	●	●
Check the sidestand			●	●	●	●	●
Check tightness of the front wheel axle nut			●	●	●	●	●
Check tightness of the rear wheel axle nut			●	●	●	●	●
Check the external fuel hoses			●	●	●	●	●
Change the front fork oil					●		
Check the forks and rear shock absorber for oil leaks			●	●	●	●	●
Check the front sprocket retaining bolts			●	●	●	●	●
General lubrication and greasing			●	●	●	●	●

List of operations with type of intervention (distance or time interval *)	km. x1000	1	12	24	36	48	60
	Months	6	12	24	36	48	60
Check and recharge the battery			●	●	●	●	●
Road test the motorcycle		●	●	●	●	●	●
General cleaning			●	●	●	●	●

* Service operation to be carried out in accordance with the specified distance or time intervals (km or months), whichever occurs first.

(1) Operation to be carried out only at the specified distance intervals

Programmed maintenance plan: operations to be carried out by the dealer

List of operations with type of intervention (distance or time interval *)	km x1000	1
	Months	6
Check the engine oil level		●
Check the brake and clutch fluid levels		●
Check tyre pressure and wear		●
Check the drive chain tension and lubrication		●
Check the brake pads. If necessary, contact your dealer to renew pads		●

*** Service operation to be carried out in accordance with the specified distance or time intervals (km or months), whichever occurs first.**

Technical data

Weights

Dry weight in riding order without fuel:

182 kg

Fully laden: 390 kg



Warning

Failure to observe weight limits could result in poor handling and impair the performance of your motorcycle, and could result in loss of control.

Overall dimensions (mm) (fig. 60)

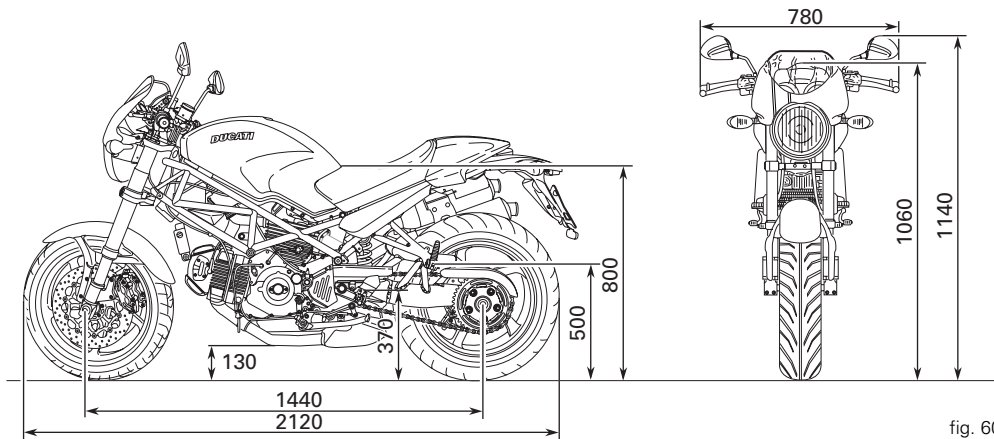

fig. 60

Fuel, lubricants and other fluids	Type	dm³ (litres)
Fuel tank, including a reserve of 3 dm ³ (litres)	Unleaded fuel with at least 95 octane rating	14
Sump and filter	SHELL - Advance Ultra 4	3.3
Front/rear brake and clutch circuits	SHELL Advance Brake DOT 4	—
Protection for electrical contacts	SHELL Advance Contact Cleaner	—
Front fork	SHELL Advance Fork 7.5 or Donax TA	0.450 (each leg)



Important

Do not use additives in fuel or lubricants.

Engine

Longitudinal 90° "L" twin cylinder, four-stroke.

Bore (mm):

88

Stroke (mm):

66

Total displacement cm³:

803

Compression ratio $\pm 0.5:1$:

10,5

Max power at crankshaft (95/1/EC)

54 kW at 8250 rpm, for the restricted power version, 23 kW at 8.000 rpm.

Max torque at crankshaft (95/1/EC):

68 Nm at 6500 rpm, for the restricted power version 48 Nm at 3000 rpm.

Timing system

Desmodromic with two valves per cylinder, operated by four rocker arms (two opening rockers and two closing rockers) and one overhead camshaft. Driven by the crankshaft through spur gears, timing belt pulleys and toothed timing belts.

Desmodromic timing system (fig. 61)

- 1) Opening (or upper) rocker arm;
- 2) opening shim;
- 3) half rings;
- 4) closing (or lower) shim;
- 5) return spring for closing rocker;
- 6) closing (or lower) rocker arm;
- 7) camshaft;
- 8) valve.

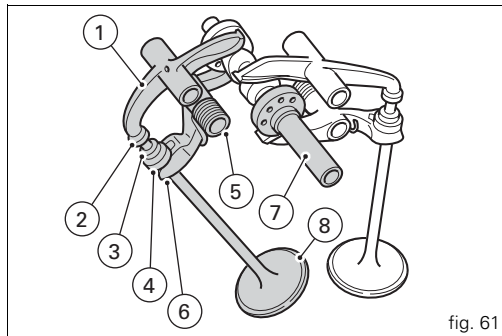

fig. 61

Performance data

Maximum speed in any gear should be reached only after the correct running-in period with the motorcycle properly serviced at the recommended intervals.

Important

Failure to follow these instructions will release Ducati Motor Holding S.p.A. from any liability for any engine damage or shortened engine life.

Spark plugs

Make:
CHAMPION
Type:
RA 4 HC.
Make:
NGK
Type:
DCPR8E.

Fuel system

Indirect electronic injection (MARELLI)
Throttle body diameter:
45 mm
Injectors per cylinder: 1
Holes per injector: 1
Fuel supply: 95-98 RON.

Brakes

Front

Type:
drilled steel disc.
2 discs.
Disc diameter:
300 mm.
Hydraulically operated by a control lever on right handlebar.
Braking surface, cm²:
44 per disc
Differential bore brake calipers.
Make and type:
BREMBO PF2x28 2 pistons.
Friction material:
FERIT I/D 450 FF.
Master cylinder type:
PS 15.

Rear

Type:
with fixed drilled steel disc.
Disc diameter:
245 mm.
Hydraulically operated by pedal on R.H. side.
Braking surface:
25 cm²
Brake caliper:
32 mm \varnothing piston.
Make and type:
P 32 F

Friction material:
FERIT I/D 450 FF.
Master cylinder type:
PS 11 B.



Warning

The brake fluid used in the brake system is corrosive. In the event of accidental contact with eyes or skin, wash the affected area with copious amounts of running water.

Transmission

Clutch:

wet multiplate;

operated by control lever on left handlebar.

Transmission from engine to gearbox main shaft via spur gears.

Front sprocket/clutch sprocket ratio:

33/61

Gearbox:

6 speed;

with constant mesh gears, gearchange pedal on left.

Final drive ratio:

15/42

Total gear ratios:

1st 13/32

2nd 18/30

3rd 21/28

4th 23/26

5th 22/22

6th 26/24

Drive chain from gearbox to rear wheel:

Make:

DID

Type:

520 V6

Dimensions:

5/8" x 1/4"

No. of links:

103

E



Important

The above gear ratios are approved and should not be modified under any circumstances.

However, if you wish to tune up your motorcycle for competitions or special tracks, Ducati Motor Holding S.p.A. will be pleased to provide information about the special ratios available. Please contact a Ducati Dealer or Authorized Service Centre.



Warning

To replace the rear sprocket, contact a Ducati Dealer or Authorized Service Centre.

Incorrect replacement of this component could seriously endanger rider and passenger safety and cause irreparable damage to the motorcycle.

Frame

High-strength tubular steel trellis.

Steering angle (on each side):

27°

Steering head rake:

24°

Trail mm:

96

Wheels

Light alloy, five spokes.

Front

Make:

BREMBO

Dimensions:

MT3.50x17"

Rear

Make:

BREMBO

Dimensions:

MT5.50x17"

Both wheels have removable axles.

Tyres

Front

Radial tubeless tyre

Size:

120/70-ZR17

Rear

Radial tubeless tyre

Size:

180/55-ZR17

Suspension

Front

Upside-down hydraulic forks.

Stanchion diameter: 43 mm.

Travel along leg axis 130 mm.

Rear

Progressive linkage with a rocker arm connecting the frame and upper pivot point of the shock absorber. Adjustable rebound damping and spring preload. Pivots at the lower end on the aluminium swingarm.

The swingarm pivots on a shaft which passes through the engine. This system gives the motorcycle excellent stability.

Shock absorber travel: 65 mm.

Rear wheel travel: 148 mm.



Notes

Do not carry out any operations on the motorcycle that could modify the technical characteristics for which approval was obtained.

Exhaust system

Equipped with catalytic converter in compliance with Euro 3 emission regulations.

USA model: not catalyzed.

Available colours

E

S2R

Ducati anniversary red, code F_473.101 (PPG);

Transparent, code 228.880 (PPG)

with white stripe

Red frame with white wheels.

Tangerine Red, code *0035 (PPG);

Transparent, code 228.880 (PPG)

with black stripe;

Black frame and wheels.

Glossy black, code 248.514 (PPG);

Transparent, code 228.880 (PPG)

with Tangerine Red stripe;

Black frame and wheels.

Dark black, code 291.501 (PPG);

Black frame and wheels.

Electrical system

The main components of the electrical system are:

front headlight:

bulb type: **H4 (12 V-55/60 W)**.

side light:

bulb type: **T4W (12 V-4 W)**.

Electrical controls on handlebars:

turn signals:

bulb type: **R10W (12 V-10 W)**.

Horn

Brake light switches.

Battery, 12 V-10 Ah.

Alternator, 12 V-520 W.

Electronic voltage regulator (rectifier), protected by a **40 A** fuse near the battery.

Starter motor, 12 V-0.7 kW.

Tail light and brake light:

bulb type: **P21/5W (12 V-5/21 W)**.

Number plate light:

bulb type: **W5W (12 V-5 W)**.



Notes

To replace the bulbs, refer to the paragraph "Changing the bulbs" on page 56.

Fuses

The main fuse box is located on the left of the battery (fig. 62).

The fuses are accessed by removing the cover (1), which shows the ampere ratings and mounting locations. The fusebox contains six fuses plus two spares.

The 40A fuse (2) on the right of the battery (fig. 62) protects the electronic voltage regulator.

To access this fuse, remove the protective cap (3).

A blown fuse can be identified by a broken filament (4, fig. 63).

Important

To avoid possible short circuits, switch the ignition key to **OFF** before renewing the fuse.

Warning

Never use a fuse with a rating other than that specified. Failure to observe this rule may damage the electric system or even cause fire.

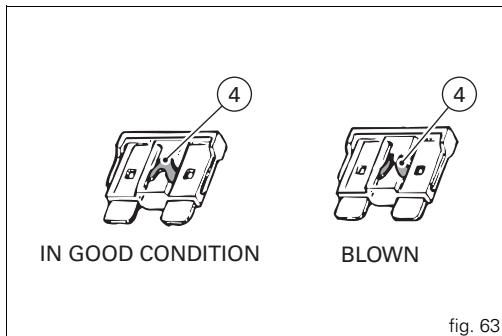
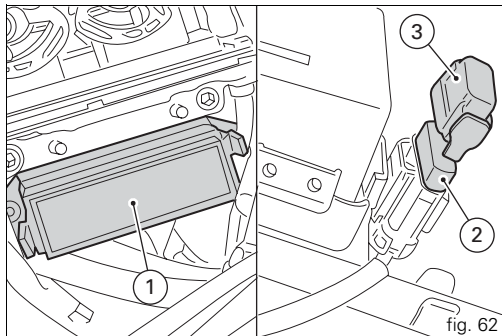

Key to the electrical system/injection system diagram (MS2R E3)

- | | |
|--------------------------------------|---|
| 1) Right-hand handlebar switch | 31) Oil pressure switch |
| 2) Transponder antenna | 32) Rear brake switch |
| 3) Key switch | 33) Front brake switch |
| 4) Lights relay | 34) Left-hand handlebar switch |
| 5) Fusebox | 35) Air temperature/pressure sensor |
| 6) Starter motor | 36) Instrument panel |
| 7) Starter contactor | 37) Front left turn signal |
| 8) Battery | 38) Horn |
| 9) Master fuse | 39) Headlight |
| 10) Regulator | 40) Front right turn signal |
| 11) Alternator | 41) ECU oil temperature sensor |
| 12) Rear right turn signal | 42) Instrument panel oil temperature sensor |
| 13) Tail light | 43) Clutch switch |
| 14) Number plate light | 44) Lambda sensor |
| 15) Rear left turn signal | |
| 16) Fuel tank | |
| 17) Self-diagnosis connection | |
| 18) Speed sensor | |
| 19) Horizontal cylinder coil | |
| 20) Vertical cylinder coil | |
| 21) Horizontal cylinder spark plug 1 | |
| 22) Vertical cylinder spark plug 1 | |
| 23) Horizontal cylinder injector | |
| 24) Vertical cylinder injector | |
| 25) Throttle position sensor | |
| 26) Rpm/timing sensor | |
| 27) Sidestand switch | |
| 28) ECU | |
| 29) Injection relay | |
| 30) Neutral indicator switch | |

Key to the electrical system/injection system diagram (MS2R USA)

- | | |
|--------------------------------------|---|
| 1) Right-hand handlebar switch | 31) Oil pressure switch |
| 2) Transponder antenna | 32) Rear brake switch |
| 3) Key switch | 33) Front brake switch |
| 4) Main relay | 34) Left-hand handlebar switch |
| 5) Fusebox | 35) Air temperature/pressure sensor |
| 6) Starter motor | 36) Instrument panel |
| 7) Starter contactor | 37) Front left turn signal |
| 8) Battery | 38) Horn |
| 9) Regulator fuse | 39) Headlight |
| 10) Regulator | 40) Front right turn signal |
| 11) Alternator | 41) ECU oil temperature sensor |
| 12) Rear right turn signal | 42) Instrument panel oil temperature sensor |
| 13) Tail light | 43) Clutch switch |
| 14) Number plate light | 44) Service socket |
| 15) Rear left turn signal | |
| 16) Fuel tank | |
| 17) Self-diagnosis connection | |
| 18) Speed sensor | |
| 19) Horizontal cylinder coil | |
| 20) Vertical cylinder coil | |
| 21) Horizontal cylinder spark plug 1 | |
| 22) Vertical cylinder spark plug 1 | |
| 23) Horizontal cylinder injector | |
| 24) Vertical cylinder injector | |
| 25) Throttle position sensor | |
| 26) Rpm/timing sensor | |
| 27) Sidestand switch | |
| 28) 5AM control unit | |
| 29) Injection relay | |
| 30) Neutral indicator switch | |

Wire colour code

B Blue
W White
V Violet
Bk Black
Y Yellow
R Red
Lb Light blue
Gr Grey
G Green
Bn Brown
O Orange
P Pink

E

Key to fusebox (MS2R E3)

Pos.	Device	Val.
1-9	Instrument panel	5 A
2-10	Injection	20 A
3-11	Key sense	10 A
4-12	ECU	5 A
5-13	Loads	15 A
6-14	Side light, high/low beam	15 A
7-15	Fuel warning	20 A
8-16	Fuel warning	5 A



Notes

The electrical system wiring diagram is at the end of this manual.

Key to fusebox (MS2R USA)

Pos.	Device	Val.
1-9	General	30 A
2-10	Fuel pump, injectors, coils	20 A
3-11	Key sense	10 A
4-12	ECU power	3 A
5-13	Passing light	7,5 A
6-14	Side light, instrument panel, high/low beam	15 A
7-15	Brake light, horn	10 A
8-16	Service socket	5 A



Notes

The electrical system wiring diagram is at the end of this manual.

Periodic maintenance record

km	Name of Ducati Service	Mileage	Date
1000			
12000			
24000			
36000			
48000			
60000			

E

For United States of America Version Only

Reporting of safety defects

If you believe that your vehicle has a defect which could cause a crash or could cause injury or death, you should immediately inform the National Highway Traffic Safety Administration (NHTSA) in addition to notifying Ducati North America. If NHTSA receives similar complaints, it may open an investigation, and if it finds that a safety defect exists in a group of vehicles, it may order a recall and remedy campaign. However, NHTSA cannot become involved in individual problems between you, your dealer, or Ducati North America. To contact NHTSA, you may either call the Auto Safety Hotline toll-free at 1-800-424-9393 (or 366-0123 in Washington, D.C. area) or write to: NHTSA, U.S. Department of Transportation, Washington, D.C. 20590. You can also obtain other information about motor vehicle safety from the Hotline.

Safety warnings

Traffic Rules vary from jurisdiction to jurisdiction. Know the regulations in your jurisdiction before riding this motorcycle.



Warning

This motorcycle is designed and intended for use on streets and other smooth, paved areas only. Do not use this motorcycle on unpaved surfaces. Such use could lead to upset or other accident.

Noise emission warranty

Ducati Motor S.p.A. warrants that this exhaust system, at the time of sale, meets all applicable U.S. EPA Federal noise standards. This warranty extends to the first person who buys this exhaust system for purposes other than resale, and to all subsequent buyers. Warranty claims should be directed to: Ducati North America, Inc., 10443 Bandle Drive, Cupertino, California, 95014
Tel: 001.408.253.0499 - Fax: 001.408.253.4099

Noise and exhaust emission control system information

Source of Emissions

The combustion process produces carbon monoxide and hydrocarbons. Control of hydrocarbons is very important because under certain conditions, they react to form photochemical smog when subjected to sunlight. Carbon monoxide does not react in the same way, but is toxic. Ducati utilizes lean carburetor settings and other systems to reduce carbon monoxide and hydrocarbons.

Exhaust Emission Control System

The Exhaust Emission Control System is composed of lean carburetor settings, and no adjustments should be made except idle speed adjustments with the throttle stop screw. The Exhaust Emission Control System is separate from the crankcase emission control system.

Crankcase Emission Control System

The engine is equipped with a closed crankcase system to prevent discharging crankcase emissions into the atmosphere. Blow-by gas is returned to the combustion chamber through the air cleaner and the throttle body.

Evaporative Emission Control System

California motorcycles are equipped with an evaporative emission control system which consists of a charcoal canister and associated piping. This system prevents the escape of fuel vapors from the throttle body and fuel tank.

Tampering warning

Tampering with Noise Control System Prohibited. Federal Law prohibits the following acts or causing thereof:

(1) the removal or rendering inoperative by any person, other than for purposes of maintenance, repair, or replacement, of any device or element of design incorporated into any new vehicle for the purpose of noise control prior to its sale or delivery to the ultimate purchaser or while it is in use; or
(2) the use of the vehicle after such device or element of design has been removed or rendered inoperative by any person.

Among those acts presumed to constitute tampering are the acts listed below:

- (1) Removal of, or puncturing the muffler, baffles, header pipes or any other component which conducts exhaust gases.
- (2) Removal or puncturing of any part of the intake system.
- (3) Lack of proper maintenance.
- (4) Replacing any moving part of the vehicle, or parts of the exhaust or intake system, with parts other than those specified by the manufacturer.

This product should be checked for repair or replacement if the motorcycle noise has increased significantly through use. Otherwise, the owner may become subject to penalties under state and local ordinances.

Problems that may affect motorcycle emissions

If you are aware of any of the following symptoms, have the vehicle inspected and repaired by your local Ducati dealer.

Symptoms:

Hard starting or stalling after starting.

Rough idle.

Misfiring or backfiring during acceleration.

After-burning (backfiring).

Poor performance (driveability) and poor economy.

Riding safety

The points given below are applicable for every day motorcycle use and should be carefully observed for safe and effective vehicle operation.

A motorcycle does not provide the impact protection of an automobile, so defensive riding in addition to wearing protective apparel is extremely important.

Do not let protective apparel give you a false sense of security.

Before changing lanes, look over your shoulder to make sure the way is clear. Do not rely solely on the rear view mirror; you may misjudge a vehicle's distance and speed, or you may not see it at all.

When going up steep slopes, shift to a lower gear so that there is plenty of power to spare rather than overloading the engine.

When applying the brakes, use both the front and rear brakes. Applying only one brake for sudden braking may cause the motorcycle to skid and lose control.

When going down long slopes, control vehicle speed by closing the throttle. Use the front and rear brakes for auxiliary braking.

Riding at the proper rate of speed and avoiding unnecessarily fast acceleration are important not only for safety and low fuel consumption but also for long vehicle life and quieter operation.

When riding in wet conditions or on loose roadway surfaces, the ability to maneuver will be reduced. All of your actions should be smooth under these conditions. Sudden acceleration, braking or turning may cause loss of control.

When the roadway is wet, rely more on the throttle to control vehicle speed and less on the front and rear brakes.

The throttle should also be used judiciously to avoid skidding the rear wheel from too rapid acceleration or deceleration.

On rough roads, exercise caution, slow down, and grip the fuel tank with your knees for better stability.

When quick acceleration is necessary as in passing, shift to a lower gear to obtain the necessary power.

Do not down shift at too high an r.p.m. to avoid damage to the engine from overrevving.

Avoiding unnecessary weaving is important to the safety of both the rider and other motorists.

Do not exceed the legal speed limit or drive too fast for existing conditions. High speed increases the influence of any condition affecting stability and the loss of control.

Operate motorcycle only at moderate speed and out of traffic until you have become thoroughly familiar with its operation and handling characteristics under all conditions.

This is a very high performance motorcycle, designed and intended for use by experienced careful riders only!

A new motorcycle must be operated according to a special break-in procedure (see Running in recommendations).



Warning

Before starting engine, check for proper operation of brake, clutch, shifter, throttle controls, correct fuel and oil supply.

Gasoline is extremely flammable and is explosive under certain conditions. Refuell in a well ventilated area with the engine stopped. Do not smoke or allow open flames or sparks when refuelling or servicing the fuel system.

Always close the fuel petcock when the engine is not running to prevent flooding of the throttle body. Do not overfill fuel tank (see instructions page 40).

Motorcycle exhaust contains poisonous carbon monoxide gas. Do not inhale exhaust gases and never run the engine in a closed garage or confined area.

Use only Ducati approved parts and accessories.

This motorcycle was not intended to be equipped with a sidecar or to be used to tow any trailer or other vehicle.

Ducati does not manufacture sidecars or trailers and cannot predict the effects of such accessories on handling or stability, but can only warn that the effects will be adverse and any damage to motorcycle components caused by the use of such accessories will not be remedied under warranty.



Warning

Do not ride the motorcycle with helmets attached to the hook; the helmets could cause an accident by distracting the operator or interfering with normal vehicle operation.

Protective apparel

Always wear a helmet. Most motorcycle accident fatalities are due to head injuries.

For safety eye protection, gloves, and high top, sturdy boots should also be worn.

The exhaust system becomes very hot during operation, never touch the exhaust system. Wear clothing that fully covers your legs. Do not wear loose clothing which could catch on the control levers, footrests, wheels, or chain. Any amount of alcohol will significantly interfere with your ability to safely operate your motorcycle. Don't drink and ride.

Vehicle identification number (VIN)

Every Ducati motorcycle is identified by two identification numbers (see page 9). Figure A specifically shows the frame identification numbers.

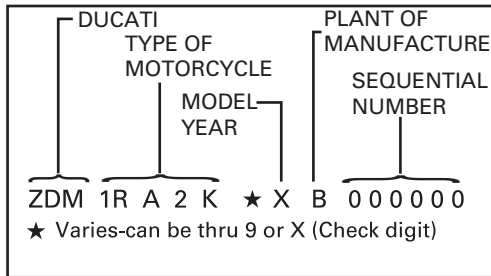

Label location (fig. B)

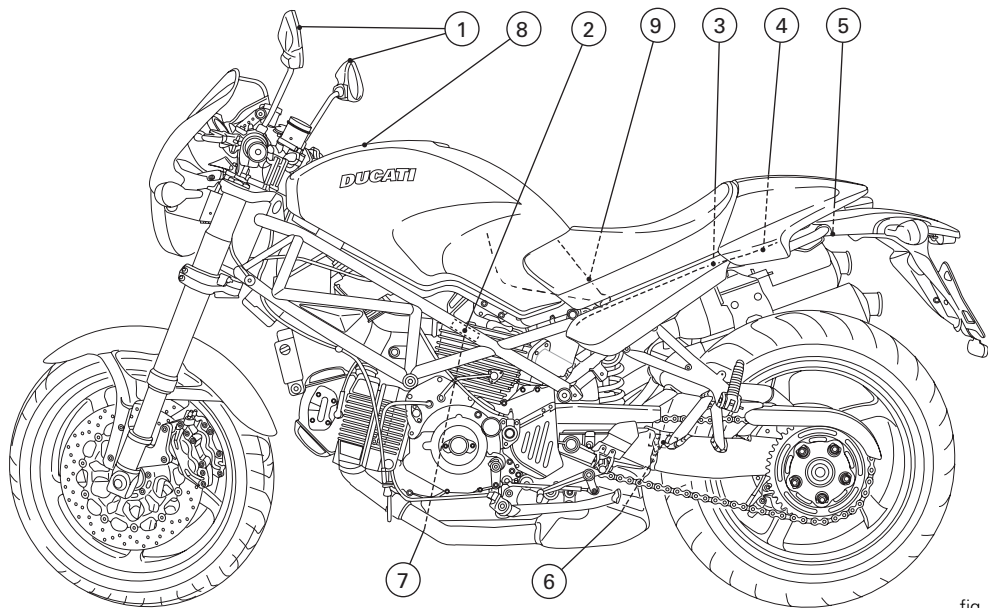

fig. B

OBJECT IN MIRROR ARE
CLOSER THAN THEY APPEAR

1

Manufactured by **DUCATI MOTORHOLDING spa**

DATE: []/[]/[]

GVWR: [] Lbs ([] kg)
 GAWR front: [] Lbs ([] kg) with [] tire, [] RIM at [] PSI cold.
 GAWR rear: [] Lbs ([] kg) with [] tire, [] RIM at [] PSI cold.
 This vehicle conforms to all applicable Federal Motor Vehicle Safety standards in effect on the date of manufacture shown above. Type classification: Motorcycle

Vehicle I.D. No.: []

544.987.001.00

2

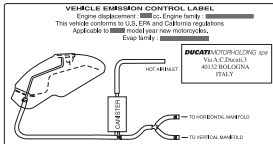

3

VEHICLE EMISSION CONTROL INFORMATION

Engine displacement: [] cc	THIS VEHICLE CONFORMS TO U.S. EPA AND CALIFORNIA REGULATIONS APPLICABLE TO [] MODEL YEAR NEW MOTORCYCLES AND IS CERTIFIED TO 1.4 HC GKM ENGINE FAMILY EXHAUST EMISSION STANDARD IN CALIFORNIA	
Engine family: []		
Engine exhaust control system: []		
Evap family: []		
ENGINE TUNE-UP SPECIFICATIONS		
ITEM	SPECIFICATIONS	INSTRUCTIONS
IGNITION TIMING:	[] ; 5°DC at idle speed	No adjustment
IDLE SPEED (RPM):	[] mm	No adjustment
IDLE MIXTURE:	[] mm	No adjustment
VALVE CLEARANCE (in & ex):	Opening [] mm Closing [] mm	See Service Manual
SPARK PLUG: CHAMPION	OIL: []	
SPARK PLUG GAP (mm): []	FUEL: Unleaded gasoline	

DUCATI MOTORHOLDING spa - BOLOGNA - ITALY

4

HELMET HOLDER
UNDER THE SEAT

5

Tensione catena (sul cavalletto laterale)
Chain Tension Adjustment (on side stand)

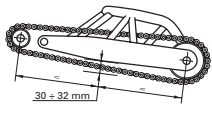

6

MOTORCYCLE NOISE EMISSION CONTROL INFORMATION

THIS [] MOTORCYCLE, [] MEETS EPA NOISE EMISSION REQUIREMENTS OF [] dBA AT [] RPM BY THE FEDERAL TEST PROCEDURE. MODIFICATIONS WHICH CAUSE THIS MOTORCYCLE TO EXCEED FEDERAL NOISE STANDARDS ARE PROHIBITED BY FEDERAL LAW. SEE OWNER'S MANUAL.

544.987.001.00

7

CAUTION

NEVER FILL TANK SO FUEL LEVEL RISES INTO FILLER NECK. IF TANK IS OVERFILLED, HEAT MAY CAUSE FUEL TO EXPAND AND FLOW INTO EVAPORATIVE EMISSION CONTROL SYSTEM RESULTING IN HARD STARTING AND ENGINE HESITATION.

8

ATTENZIONE! Per evitare pericoli di carburante dal tubo di sfogo, evitare di sovrare il serbatoio quando questo è pieno oltre la misura.

ATTENTION! To avoid fuel leaks from the breather pipe, do not fill the tank when it is more than full.

9

California evaporation emission system (fig. C)

Important

In the event of fuel system malfunction, contact Ducati's authorized Service Centres.

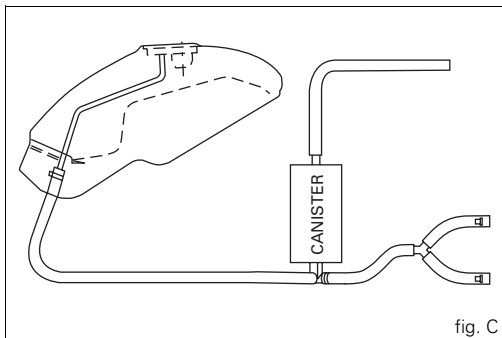

fig. C

Ducati limited warranty on emission control system

Ducati North America, Inc., 10443 Bandlely Drive Cupertino, California, 95014 warrants that each new 1998 and later Ducati motorcycle, that includes as standard equipment a headlight, tail-light and stoplight, and is street legal:

A) is designed, built and equipped so as to conform at the time of initial retail purchase with all applicable regulations of the United States Environmental Protection Agency, and the California Air Resources Board; and
B) is free from defects in material and workmanship which cause such motorcycle to fail to conform with applicable regulations of the United States Environmental Protection Agency or the California Air Resources Board for a period of use, of 30,000 kilometers (18,641 miles), or 5 (five) years from the date of initial retail delivery, whichever first occurs.

I. Coverage

Warranty defects shall be remedied during customary business hours at any authorized Ducati motorcycle dealer located within the United States of America in compliance with the Clean Air Act and applicable regulations of the United States Environmental Protection Agency and the California Air Resources Board. Any part or parts replaced under this warranty shall become the property of Ducati. In the state of California only, emissions related warranted parts are specifically defined by that state's Emissions Warranty Parts List. These warranted parts are: carburetor and internal parts; intake manifold; fuel tank, fuel injection system; spark advance mechanism; crankcase breather; air cutoff valves; fuel tank cap for evaporative emission controlled vehicles; oil filler cap; pressure control valve;

fuel/vapor separator; canister; igniters; breaker governors; ignition coils; ignition wires; ignition points, condensers, and spark plugs if failure occurs prior to the first scheduled replacement, and hoses, clamps, fittings and tubing used directly in these parts. Since emission related parts may vary from model to model, certain models may not contain all of these parts and certain models may contain functionally equivalent parts.

In the state of California only, Emission Control System emergency repairs, as provided for in the California Administrative Code, may be performed by other than an authorized Ducati dealer. An emergency situation occurs when an authorized Ducati dealer is not reasonably available, a part is not available within 30 days, or a repair is not complete within 30 days. Any replacement part can be used in an emergency repair. Ducati will reimburse the owner for the expenses, including diagnosis, not to exceed Ducati's suggested retail price for all warranted parts replaced and labor charges based on Ducati's recommended time allowance for the warranty repair and the geographically appropriate hourly labor rate. The owner may be required to keep receipts and failed parts in order to receive compensation.

II. Limitations

This Emission Control System Warranty shall not cover any of the following:

- A. Repair or replacement required as a result of
- (1) accident,
 - (2) misuse,
 - (3) repairs improperly performed or replacements improperly installed,

(4) use of replacement parts or accessories not conforming to Ducati specifications which adversely affect performance and/or

(5) use in competitive racing or related events.

B. Inspections, replacement of parts and other services and adjustments required for routine maintenance.

C. Any motorcycle on which odometer mileage has been changed so that actual mileage cannot be readily determined.

III. Limited liability

A. The liability of Ducati under this Emission Control Systems Warranty is limited solely to the remedying of defects in material or workmanship by an authorized Ducati motorcycle dealer at its place of business during customary business hours. This warranty does not cover inconvenience or loss of use of the motorcycle or transportation of the motorcycle to or from the Ducati dealer. Ducati shall not be liable for any other expenses, loss or damage, whether direct, incidental, consequential or exemplary arising in connection with the sale or use of or inability to use the Ducati motorcycle for any purpose. Some states do not allow the exclusion or limitation of any incidental or consequential damages, so the above limitations may not apply to you.

B. No express emission control system warranty is given by Ducati except as specifically set forth herein. Any emission control system warranty implied by law, including any warranty of merchantability or fitness for a particular purpose, is limited to the express emission control systems warranty terms stated in this warranty. The foregoing statements of warranty are exclusive and in lieu of all other remedies.

Some states do not allow limitations on how long an implied warranty lasts so the above limitation may not apply to you.
C. No dealer is authorized to modify this Ducati Limited Emission Control Systems Warranty.

IV. Legal rights

This warranty gives you specific legal rights, and you may also have other rights which vary from state to state.

V. This warranty is in addition to the Ducati limited motorcycle warranty.

VI. Additional information

Any replacement part that is equivalent in performance and durability may be used in the performance of any maintenance or repairs. However, Ducati is not liable for these parts. The owner is responsible for the performance of all required maintenance. Such maintenance may be performed at a service establishment or by any individual. The warranty period begins on the date the motorcycle is delivered to an ultimate purchaser.

Ducati North America, Inc.
10443 Bandlely Drive
Cupertino, California, 95014
Tel: 001.408.253.0499
Fax: 001.408.253.4099
E-mail: customerservice@ducatiusa.com
Web site: www.ducatiusa.com

Routine maintenance record

USA

Km	Ducati Service Name	Mileage	Date
1,000			
12,000			
24,000			
36,000			
48,000			
60,000			

Stampato 03/2006

Cod. 913.7.102.1L

DUCATI 

Ducati Motor Holding spa via Cavalieri Ducati, 3 40132 Bologna, Italia
Tel. +39 051 6413111 Fax +39 051 406580
www.ducati.com

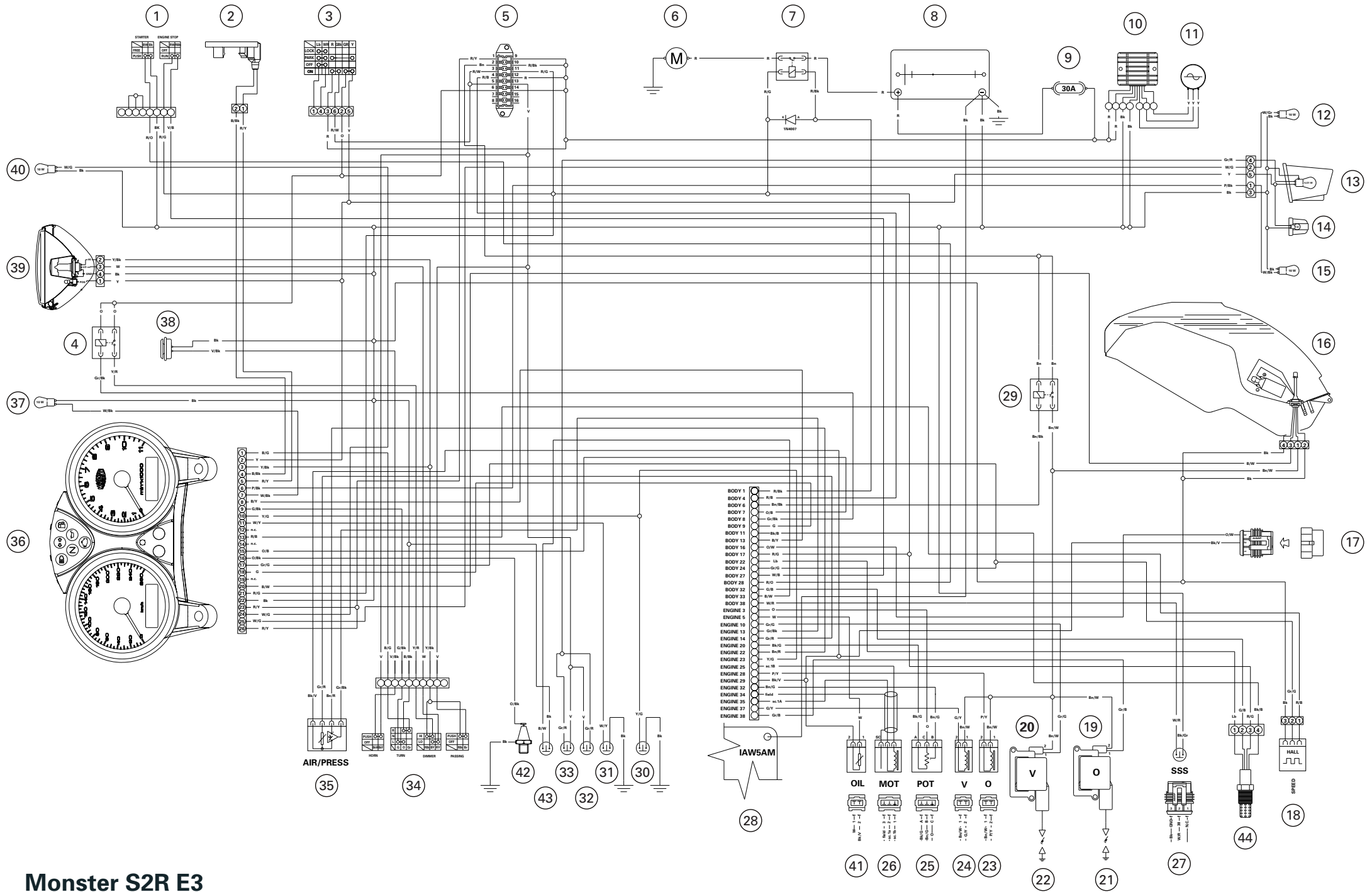

Monster S2R E3
Monster S2RDark E3

